



# **OASIS A200**

## **All-in-One**

125kW/200kWh Battery Storage System

User Manual



---

## **Preface**

Thank you sincerely for purchasing and exploring products developed and manufactured by Shenzhen Sunwoda Energy Technology Co., Ltd. (hereinafter referred to as "Sunwoda"). We genuinely hope that our products and this manual will meet your needs. Your valuable feedback is warmly welcomed, and we will continuously improve and enhance our offerings.

The copyright of this user manual is owned by Sunwoda. All rights not expressly granted herein are reserved. The content is subject to change based on the latest physical product, and revisions may be made without prior notice.

Due to product version upgrades or other reasons, this document may be updated periodically. Unless otherwise agreed, this document serves solely as a product guide. All statements, information, and recommendations provided herein do not constitute any express or implied warranties.

This document and all information contained within are the exclusive property of Sunwoda. No party shall be granted any license to patents, copyrights, trademarks, or other intellectual property rights of the other party through implication, estoppel, or otherwise, based on this document.

For updates or additional information, please contact Sunwoda.

---

## Content

Preface.....	1
Content.....	2
I. About This Manual .....	4
1.1 Attention.....	4
1.2 Applicable Model.....	4
1.3 Target Group .....	5
II. Safety Statement.....	6
2.1 General Requirement .....	6
2.2 Installer .....	6
2.3 Installation Environment.....	7
2.4 Electrical Connection.....	8
2.5 Mechanical Installation.....	8
2.6 Description of the Marking.....	9
III. Product Introduction .....	11
3.1 System Introduction .....	11
3.2 Technical Parameter .....	11
3.3 Single Line Diagram .....	12
3.4 Machine Structure .....	13
IV. Transportation, storage and unpacking inspection .....	16
4.1 Transportation Requirement.....	16
4.2 Storage Requirement.....	17
4.3 Unpacking and Delivery Inspection.....	18
4.3.1 Unpacking .....	18
4.3.2 Delivery Inspection .....	19
V. Installation and Wiring .....	21
5.1 Installation Requirement.....	21
5.1.1 Installation Environment Requirement .....	21
5.1.2 Installation Carrier Requirement.....	21
5.1.3 Installation Angle Requirement.....	22
5.1.4 Installation Space Requirement.....	22
5.1.5 Installation Tool Requirement .....	23
5.2 Mechanical Installation.....	24
5.2.1 Build the Foundation .....	24
5.2.2 Foundation Construction Method.....	25
5.2.3 Handling Equipment.....	30
5.2.4 Installation Method.....	34
5.2.5 Fixed Equipment .....	37
5.3 Electrical Wiring .....	40
5.3.1 Wiring Precautions .....	40
5.3.2 Wire Harness Specification .....	40

---

5.3.3 Ground Line Connection .....	41
5.3.4 Power Line Connection .....	41
5.3.5 Communication Line Connection .....	43
5.4 Installation Inspection .....	45
5.4.1 Electrical Inspection .....	45
5.4.2 Structural Inspection.....	45
VI. Equipment Operation.....	46
6.1 Indicator Light Introduction.....	46
6.1.1 Cabinet Indicator Light .....	46
6.1.2 Control Box Indicator Light .....	46
6.2 Operation Guidance .....	46
6.2.1 Pre-operation Inspection.....	46
6.2.2 Power-up Procedure .....	47
6.2.3 Turn off the Power.....	52
6.2.4 Emergency Shutdown.....	52
VII. Maintenance Guidance .....	53
7.1 Maintenance Precautions .....	53
7.2 Maintenance Content .....	53
VIII. Fault Handling.....	56

---

## I. About This Manual

### 1.1 Attention

This product is a specialized power distribution equipment. To ensure correctness and safety of installation, use and other operations, be sure to read this manual thoroughly before starting operations. The installer should be professionally trained with a background in electrical technology and be familiar with local grid codes and related requirements. We will not be held liable for any form of damage or injury resulting from failure to follow the operating instructions highlighted in this manual.

This manual is centered around the OASIS A200 series and details its product features, installation specifications, usage practices, troubleshooting, and routine maintenance. Due to product iteration, the contents of the manual will be constantly updated, the specific product details also please refer to the actual product purchased.

Finally, we hope that this product can fully meet your needs, and we also look forward to your valuable comments on this product. If you have any requests, please feel free to feedback us.

### 1.2 Applicable Model

This manual applies to the following product model:

OASIS A200 All-in-One: CIESS-A-200

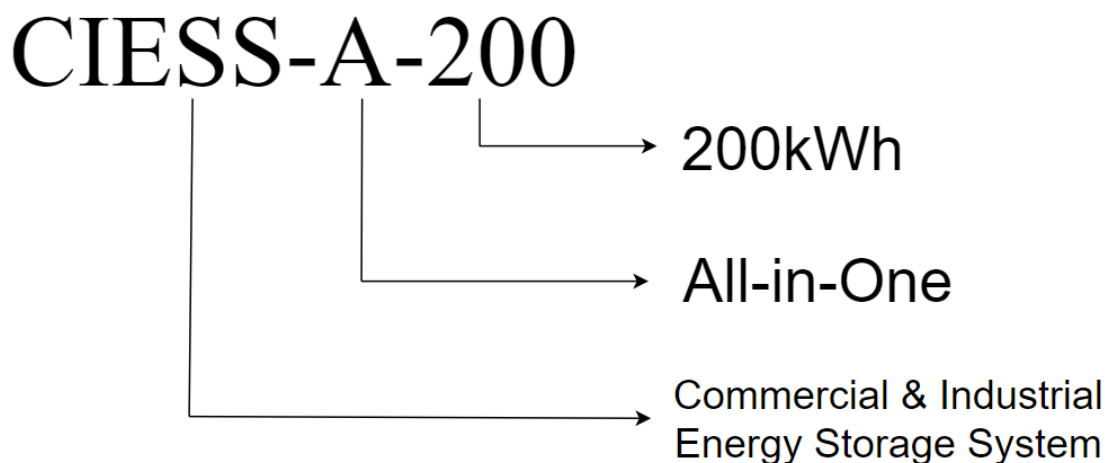

Figure 1.2.1 Description of model

---

### **1.3 Target Group**

This product should only be operated by a professional who has the following basic competencies:

(1) Professional training on how to deal with the hazards and risks arising during the installation and use of electrical equipment.

(2) Understand the installation and commissioning of conventional electrical equipment and related devices, and understand the specification requirements of local regulations and standards.

(3) Possess professional electrical certifications.

---

## **II. Safety Statement**

### **2.1 General Requirement**

- (1) Before installing the equipment, disconnect the loads and grid circuits and turn the equipment off. Avoid major injuries to personnel or major damage to equipment.
- (2) Static electricity may cause irreversible damage to the internal components of the equipment. When using the product, be sure to comply with the electrostatic protection specifications.
- (3) This product cannot be used to connect life support equipment and medical equipment directly. To ensure your safety and compliance, please consult the supplier in advance of purchase.
- (4) Before the product is turned on, please check the equipment and do not leave installation tools or other unnecessary items inside the cabinet to avoid damage to the equipment after powering on.
- (5) Maintenance equipment, be sure to ensure that the equipment has been safely disconnected from the power supply, and wait for the machine to all the electrically charged devices discharged (more than 10min), so as not to cause significant damage.

### **2.2 Installer**

- (1) All operations of the equipment must be carried out by professional, qualified technicians who have undergone special training and have professional electrical certificates, and the technicians should be familiar with the relevant standards and safety codes of the project location.
- (2) The operator should read this document before installation and understand the structure, working principle and precautions of the product in detail before starting operation.
- (3) In order to ensure personal safety, please wear personal protective equipment and prepare the insulating tools that need to be used before starting to operate the equipment. Personal protective equipment includes safety clothing, safety helmet, safety shoes, insulated gloves, goggles, etc., and insulated tools can be prepared with an insulating layer including the handle of the tool.
- (4) To ensure equipment safety, it is necessary to wear an anti-static wristband, gloves, and clothing

---

when operating electronic devices.

### **2.3 Installation Environment**

(1) In order to avoid the disturbance of the noise of the equipment operation, it is necessary to install the equipment in an area far away from the residents' life, not less than 50m.

(2) In order to ensure heat dissipation, the equipment should be in a well-ventilated space (not less than 50m<sup>3</sup>), to avoid the surrounding airflow.

(3) In order to facilitate maintenance, the equipment should leave enough space around, see chapter 5.1 for details.

(4) To ensure normal operation, the ambient temperature of the equipment should be between -30°C ~55°C.

(5) In order to guarantee the service life, please install the equipment in a dry and clean environment, avoid the air containing a lot of water vapor and dust (environmental humidity requirements: 0~95%, no condensation), avoid direct sunlight, snow and rain and other extreme environments.

(6) In order to protect the use, as far as possible to avoid equipment in the smoke, dust and other particles in the environment (air pollution index < 300), to ensure that the environment around the product is clean and tidy.

(7) To ensure use, it is strictly prohibited to operate the equipment in harsh or humid environments such as smoke, rain, snow, etc., and surrounding debris should be promptly disposed of before operation.

(8) In order to avoid equipment failure, the equipment should be installed in the area away from the liquid (not less than 50m). It is prohibited to install it below the water pipes, air outlets and other locations that are prone to condensation; it is prohibited to install it below the air conditioning outlets, vents, computer room outlet windows and other locations that are prone to water leakage.

(9) To avoid major damage, do not place flammable or explosive items around the equipment. The equipment should be kept away from any heat and fire sources.

---

(10) When the equipment is in operation, do not cover the air vents, heat dissipation system or use other items to cover them.

## **2.4 Electrical Connection**

(1) The installation of the product should meet the requirements of local power grid regulations and safety codes.

(2) Product operation involves the risk of high voltage electric shock, only electricians with specialized skills should operate the equipment.

(3) To avoid high voltage breakdown, do not touch the conductors connected to the grid circuit.

(4) Wear a static electricity bracelet when operating the electronic components inside the equipment.

(5) It is prohibited to damage the grounding conductor and to operate the equipment without the grounding conductor installed.

(6) When installing, operating, or maintaining the equipment, it is prohibited to wear watches, bracelets, bangles, rings, necklaces, and other easily conductive objects to avoid electric shock burns.

(7) The voltage at the point of contact should be measured before contacting any conductor surface or terminal to ensure that there is no danger of electric shock.

(8) Solvents such as water, alcohol or oil are prohibited to clean electrical parts inside and outside the cabinet.

(9) In the process of equipment operation, such as the discovery of faults that may lead to personal injury or equipment damage, should immediately terminate the operation, report to the person in charge, and take effective protection measures.

(10) Do not power up the equipment before installation is completed or confirmed by a professional.

## **2.5 Mechanical Installation**

(1) Considering the weight of the equipment, the person who carries out the lifting or forklift loading

---

operation needs to carry out the relevant training and be qualified before taking up the job.

(2) Work at height shall wear a helmet, safety belt or waist rope, tied to a solid and sturdy structural components, is strictly prohibited to move hanging on the unsound objects or sharp edges of the metal, to prevent the hook slipped off the fall accident.

(3) The lifting tools must be inspected, the tools need to be prepared and qualified by professional organizations, prohibit the use of scarred, unqualified or beyond the inspection of the validity of the tools to ensure that the tools are solid, and can bear the weight of the equipment.

(4) Before installing the equipment into the cabinet, first make sure that the other cabinets have been fixed to avoid the other cabinets from tilting and collapsing due to the unstable center of gravity, resulting in injuries to the installers and the equipment falling and breaking and other problems.

(5) When loading and transporting products, be careful of equipment that may be unstable or very heavy when installed in the product, and lock the front door tightly before starting transportation to avoid being crushed or smashed.

(6) Drilling holes in the equipment is strictly prohibited. Drilling holes will damage the sealing, electromagnetic shielding performance, internal devices and cables of the equipment, and metal shavings from drilling holes into the equipment will lead to a short circuit of the circuit board.











(7) Because the equipment is heavy, it is recommended that the power cables be laid before moving the equipment to its intended location. Because these cables are thick, it will be difficult to perform cable routing operations once the equipment is installed.

(8) When installing the equipment, please make sure that the bottom carrier of the cabinet is strong and reliable and can carry the weight of the cabinet to avoid damage to the equipment.

## **2.6 Description of the Marking**

For personal and equipment safety, follow the safety precautions marked on the equipment when installing, operating, and maintaining the equipment. If the relevant markings become unclear due to long-term use, replace them promptly. The categories of markings and symbols on the product are as follows.

Identifier

ICON	Description
	Front side up, it is forbidden to place the electrical cabinet horizontally, tilted or upside down.
	Carefully and gently put, to avoid the transportation environment is too intense collision friction damage to the equipment.
	Maximum number of stacking layers: 1 layer.
	Pay attention to moisture protection and avoid the product being exposed to rain or moisture.
	Take care to protect against high temperatures and avoid exposing the product to direct sunlight.
	No tumbling.
	Stay safe.
	There is an electrical hazard. Equipment should only be operated and maintained by specialized personnel.
	It is necessary to wait 10min after power failure to ensure that the machine is fully discharged!
	Hazardous hot surface symbol. Watch out for high temperatures and burns.
	The equipment needs to be recycled at the end of its life.

---

## III. Product Introduction

### 3.1 System Introduction

OASIS A200 All-in-One is a high-safety, high-reliability, and standardized product developed for commercial and industrial energy storage applications. Featuring a modular system configuration, it flexibly adapts to diverse scenarios and supports grid-connected applications. With parallel scalability, this system allows for power capacity expansion. This energy storage solution is ideal for applications requiring continuous grid stability, including peak load shifting, frequency regulation, grid load balancing and energy arbitrage.

Products include battery box, control box, energy storage converter (PCS), battery management system, fire protection system, etc.

### 3.2 Technical Parameter

Product Series	OASIS A200 All-in-One
Product Model	CISS-A-200
Battery Side Parameters	
Cell Type	LFP
Cell Specification	3.2V 314Ah
PACK Capacity	20kWh
Nominal Capacity	200kWh
Nominal Voltage	640V
AC Side Parameters	
Rated Output Power	125kW
THDi	<3% (at rated power)
Nominal Voltage	400V (300~440V)
Nominal Frequency	50/60Hz (±5Hz)
System Parameters	
Communication Interface	RS485、CAN
Display	Touchscreen, Cloud Platform,
Protection Rating	IP55
Cooling Method	Industrial Air Conditioning
Installation Type	Outdoor
Corrosion Resistance	C3
Ambient Temperature	-30°C ~ 55°C (>45°C derating)
Humidity	0 ~ 95% (non-condensing)
Noise	<75dB

Altitude	3000m
Size (W×D×H)	1150*1375*2120mm (Not including lifting ring)
Weight	<2400kg

### 3.3 Single Line Diagram

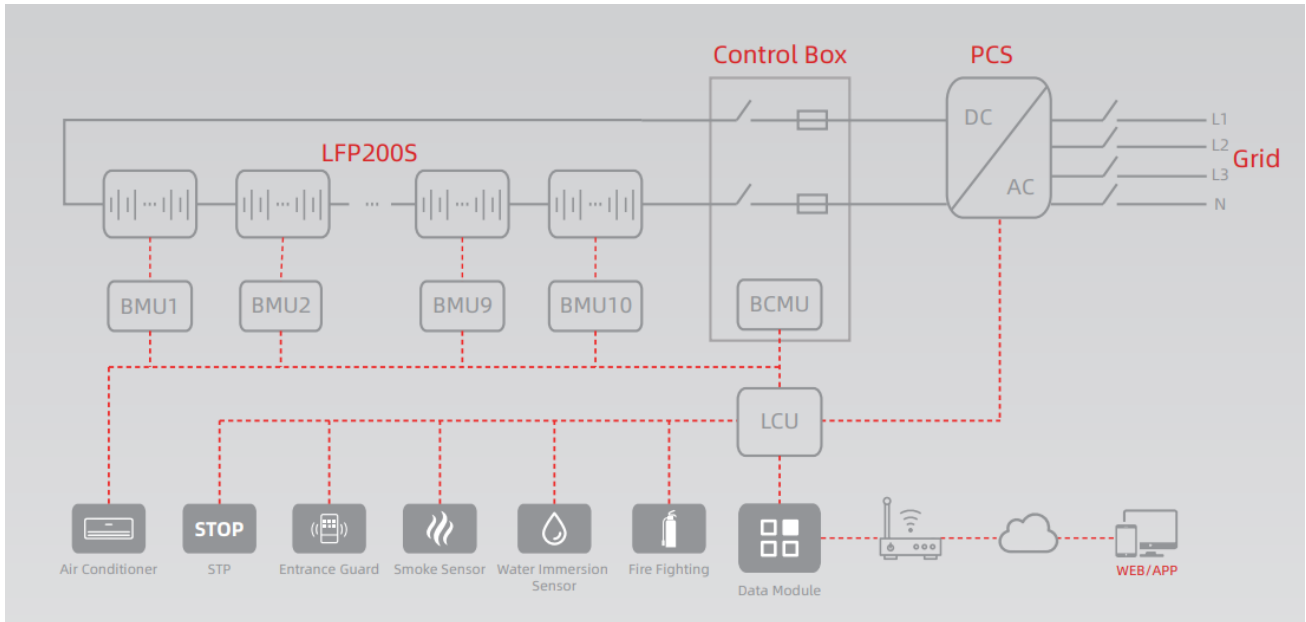

### 3.4 Machine Structure

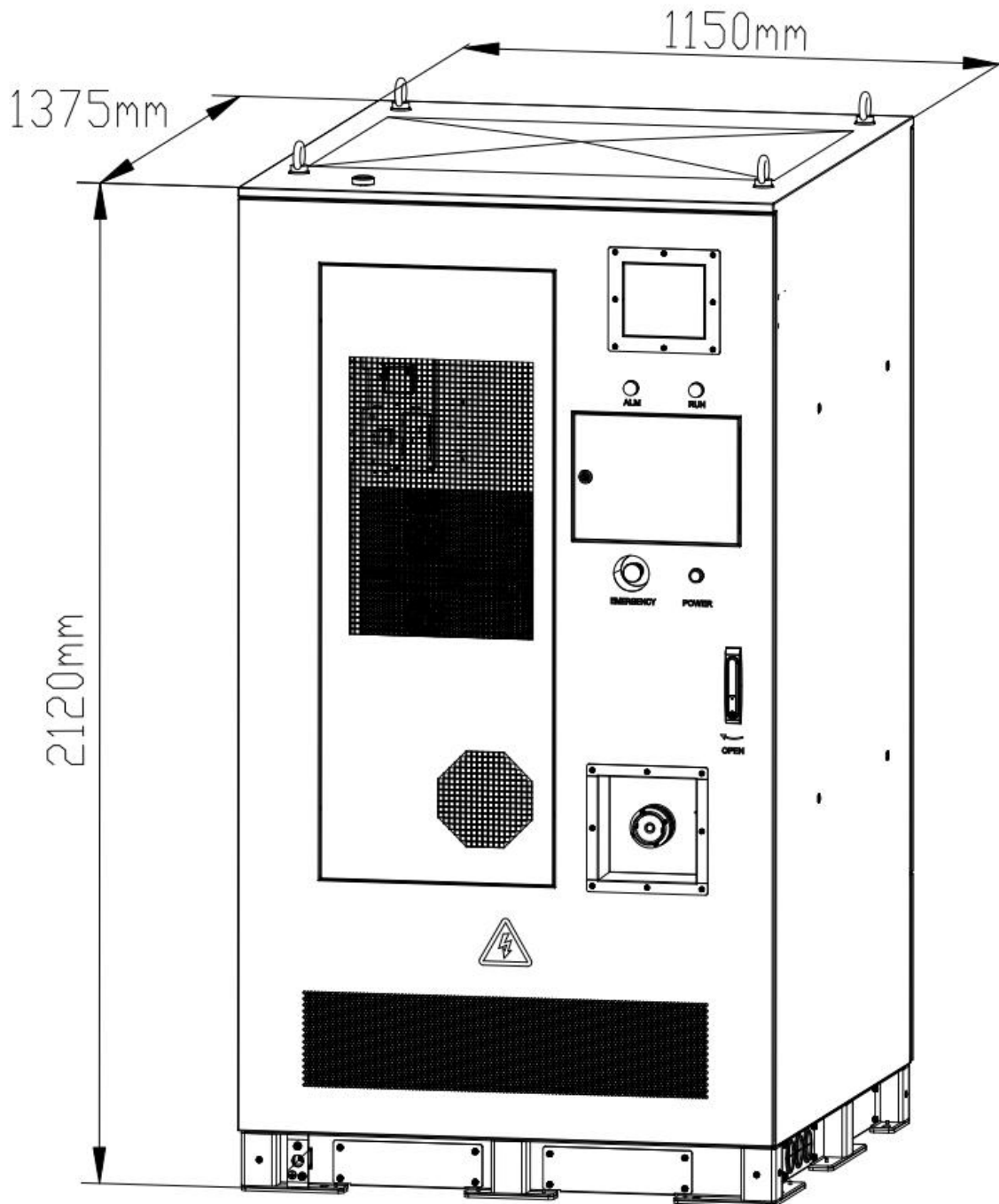
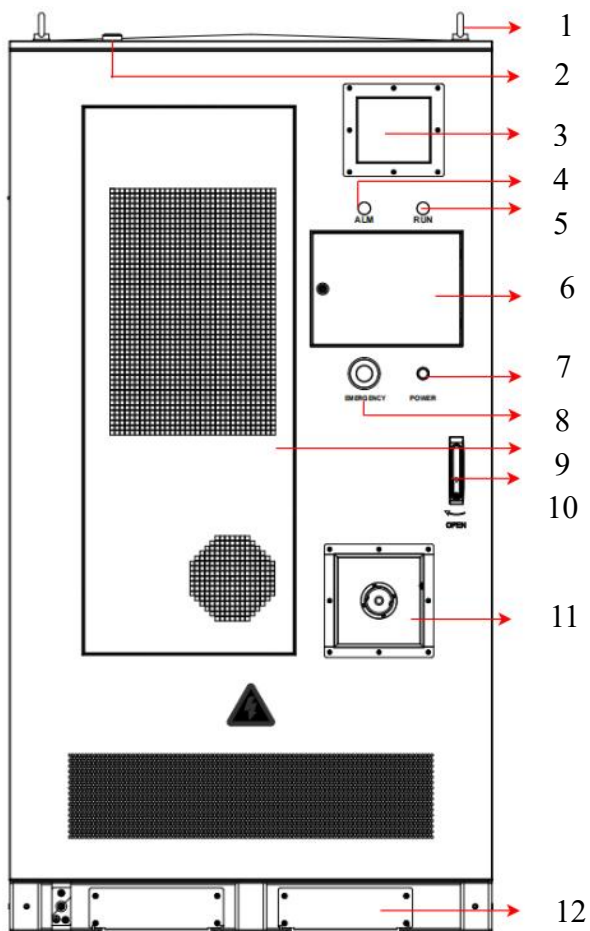
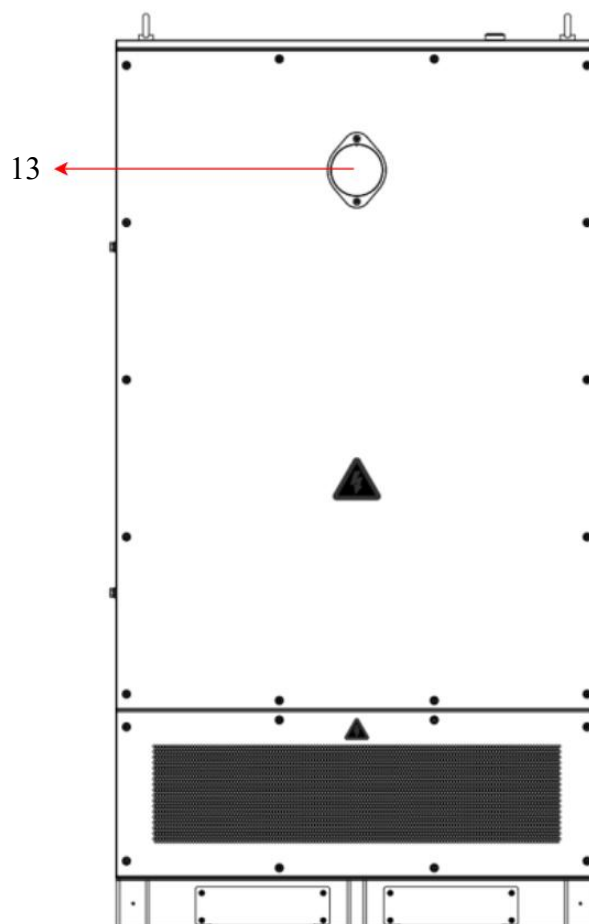

Figure 3.1.4.1 Schematic of Cabinet Dimension



Main View



Back View

NO.	Name	NO.	Name
1	Lifting Ring	8	Emergency Stop Switch
2	Antenna	9	Air Conditioner
3	Exhaust Fan	10	Door Lock
4	Fault Indicator Light	11	Water Fire Protection Interface
5	Run Indicator Light	12	Base Plate
6	Touch Screen	13	Explosion-proof Valve
7	Power on/off Button		

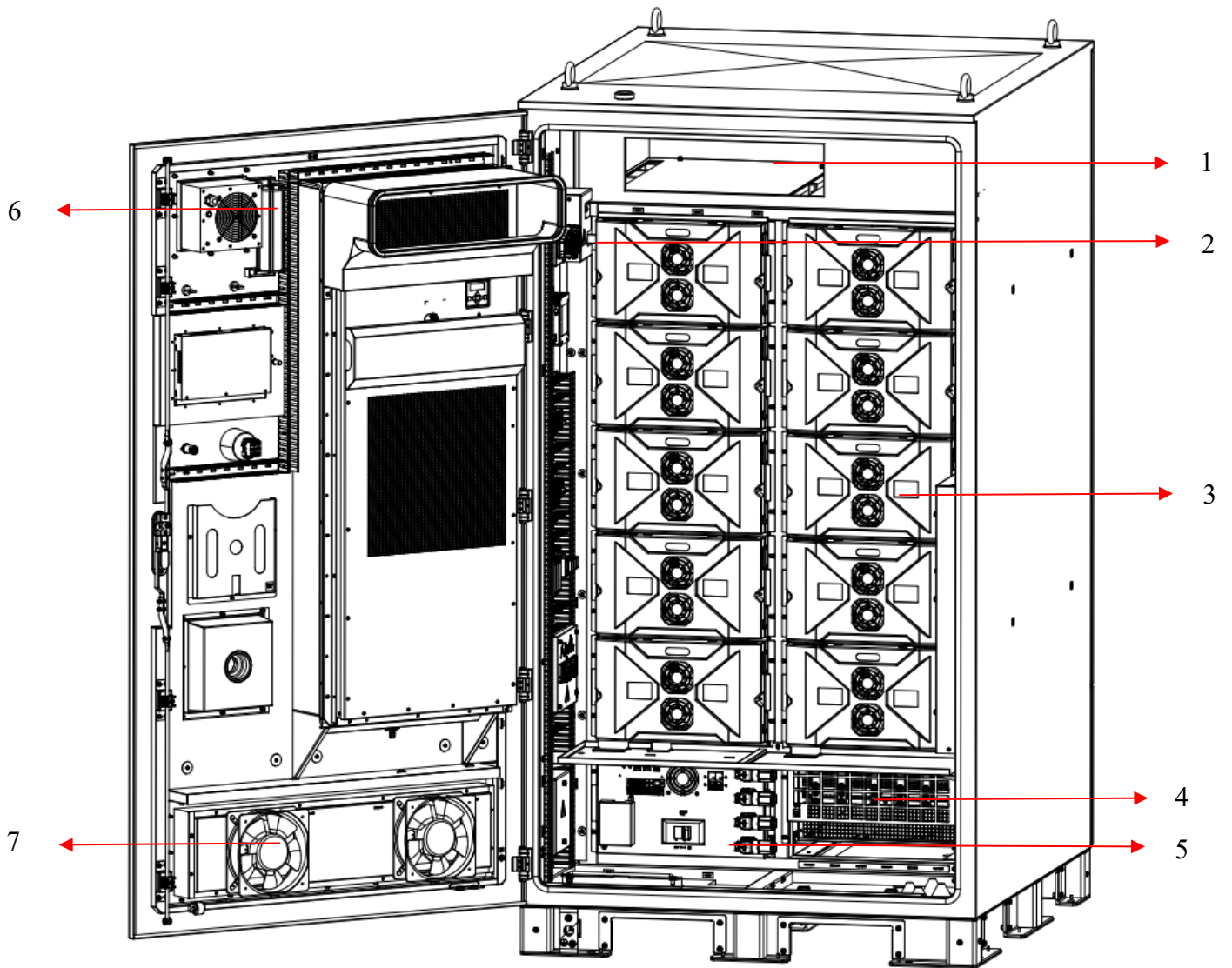

Internal Layout Diagram

NO.	Name	NO.	Name
1	Ventilation Passage	5	Control Box
2	Maintenance Switch	6	Aerosol Fire Suppression
3	Battery PACK	7	PCS Cooling Fan
4	PCS		

---

## **IV. Transportation, storage and unpacking inspection**

### **4.1 Transportation Requirement**

Improper transportation may cause injuries or equipment damage, when transporting, please be sure to follow the following transportation requirements:

(1) Please check whether the package is intact before transportation. If you find any signs of damage, do not open the package and contact your supplier.

(2) Only professionally trained and instructed personnel should carry out transportation operations on public roads.

(3) Whenever possible, transport the product in its packaging and follow the safety regulations indicated on the packaging.

(4) Please use appropriate fixing devices, such as ropes, support frames, etc., during transportation to ensure that the equipment will not be shifted due to shaking or vibration during transportation.

(5) Keep the equipment upright during transportation. Do not allow the equipment to be placed horizontally or reverse upside down, so as to avoid the internal modules of the equipment sliding and causing damage to the equipment.

(6) The tilt angle of the equipment when placed upright should be less than  $5^{\circ}$  .

(7) The equipment should be transported as a complete unit. Any detachment of the system without our permission and consequent damage to the equipment is not covered by the warranty.

(8) Avoid severe vibration, shock or crushing during transportation. Sudden lowering or lifting is also not allowed. Please minimize bumps and tilts during transportation.

(9) Please refer to the front-facing sign on the cabinet for the direction of transportation of the equipment, and avoid inverting, tilting, dropping, mechanical impact, rain, snow and falling into water.

(10) Comply with the international road transportation rules and meet the regulatory requirements of the transportation regulatory authorities of the country of origin, route and destination.

(11) The transportation should choose sea transportation or road with good condition, and do not

---

support railroad and air transportation.

(12) The loading, unloading and handling process during transportation must be carried out by professional personnel.

(13) Please pay attention to the loading and unloading and handling process during transportation, so as to avoid damage to the equipment or personnel.

(14) Be sure to wear appropriate personal protective equipment, such as helmets and non-slip shoes, during loading, unloading and handling during transportation.

(15) During transportation, make sure the foundation is protected from moisture if necessary.

(16) The loading, unloading, and handling process during transportation can be carried out by forklift, crane, or wheelbarrow, etc., and a trial loading and lifting can be carried out to ensure the load-bearing capacity of the loading equipment when forklifting or lifting.

(17) Please arrange auxiliary personnel during the handling process to avoid the situation that the equipment size is too big to block the driver's sight.

(18) Please pay attention to the center of gravity of the equipment and keep the equipment balanced.

## 4.2 Storage Requirement

If the product is not installed on site immediately after arrival, the product should be stored with the outer packaging and the following matters should be followed:

### Warning

(1) Store the battery indoors. No direct sunlight or rain, no extreme cold or heat, dry and well ventilated, away from heat and fire sources.

(2) If the battery is bulging, deformed, broken or leaking, it shall be scrapped without regard to the storage time.

(3) When storing the battery, it should be placed correctly according to the identification of the packing box, and it is strictly prohibited to place it upside down, sideways, or at an angle, and when stacking it, it should conform to the yardage requirements on the outer packaging.

(4) The site must be equipped with fire-fighting facilities that meet the requirements, such as

firefighting sand and fire extinguishers.

 **Warning**

(1) Batteries are recommended to be used in a timely manner. For batteries that have been stored for a long period of time, please carry out regular replenishment of electricity, otherwise the batteries may be damaged.

(2) The ambient air must not contain corrosive or flammable gases, the surrounding environment is clean, there is no large amount of infrared and other radiation, no organic solvents or corrosive gases, and there is no metallic conductive dust.

 **Notice**

(1) During storage, it is necessary to keep relevant proof of compliance with product storage requirements, such as temperature and humidity log data, photos of the storage environment and inspection reports.

(2) Store in a clean and dry place and protect from dust and moisture. Prohibit erosion by rain or ground water.

(3) Storage environment requirements:

Recommended storage temperature: 20°C~30°C.

Relative humidity: 5% RH~80% RH.

Dry, ventilated and clean. Avoid contact with corrosive organic solvents, gases and other substances.

Avoid direct sunlight. The distance from the heat source should not be less than two meters.

(4) From the date of shipment from the manufacturer, the battery needs to be maintained at intervals of up to 12 months, and the desiccant inside it should be replaced in a timely manner.

## 4.3 Unpacking and Delivery Inspection

### 4.3.1 Unpacking

Once the product has been transported to the vicinity of the installation site, unpack it and check that the delivery items are complete.

Step1. Remove the bolts on the four cabinet feet at the bottom of the packing crate.

Step2. Remove the top and side panels of the crate.





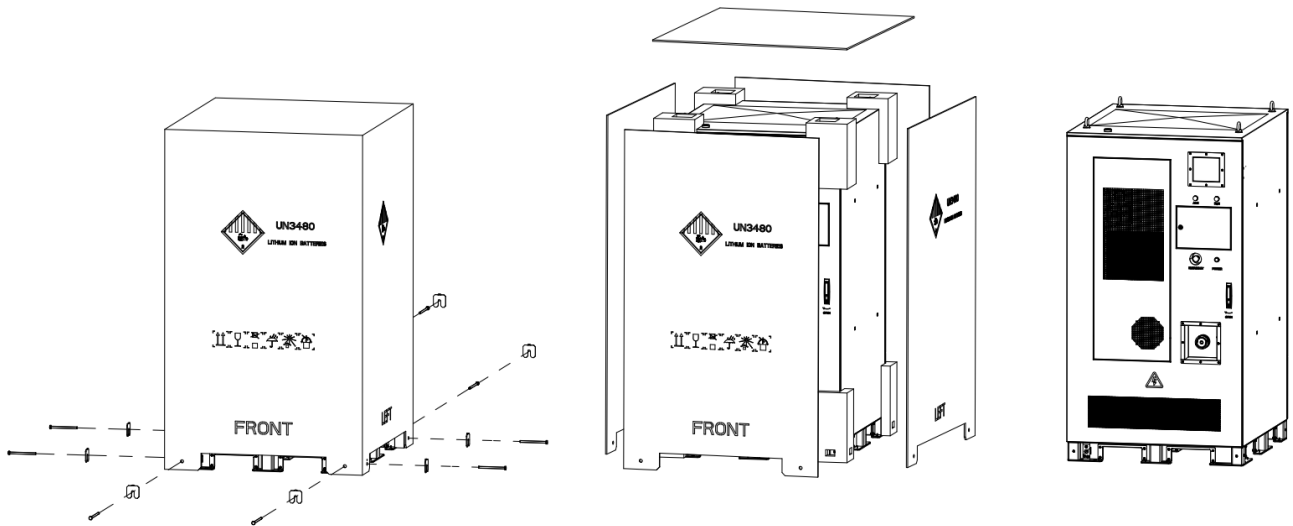

Step3. Remove the external packing materials from the product.





Step4. Open the front door of the product and check whether the delivered items are complete.



### 4.3.2 Delivery Inspection

Please check against the packing list to see if the items received are complete. The actual pictures of the items are as follows (please refer to the actual shipment):

NO.	Name	Description	Quantity	Reference Picture	Note
1	Certificate of Conformity	/	1		
2	Hex Head Bolt Assembly	M6*16	32		
		M8*20	4		
		M10*25	4		
3	Expansion Bolt	M12*110	8		To fix the cabinet
4	Extension Rod	Suitable for 400~800A shell frame plastic shell type circuit breaker	1		Auxiliary turn on and off breaker
5	OT Terminal	RNB8-6, for 8AWG (8.4mm <sup>2</sup> ) cable	6		
6	SC Terminal	SC50-8, for 50mm <sup>2</sup> cable	2		

		SC70-10, for 50mm <sup>2</sup> cable	6		
7	Maintenance Switch Plug	GCMSDP000, 1500VDC, 350A	1		
8	LCU Door Key	Supporting facilities	1		
9	Cabinet Door Key	Supporting facilities	1		
10	Forklift Hole Cover Plate	Supporting facilities	8		

---

## **V. Installation and Wiring**

### **5.1 Installation Requirement**

#### **5.1.1 Installation Environment Requirement**

- (1) Do not install in flammable, explosive, corrosive and other environments.
- (2) Please avoid children's activity area to avoid accidental contact or injury.
- (3) As far as possible to avoid the sun, rain, snow and other extreme environments.
- (4) The installation space should meet the ventilation and heat dissipation requirements of the equipment and operating space requirements (See Section 5.1.4 for details).
- (5) The installation height should be easy to maintain, to ensure that the equipment labels, indicators are easy to view, and the terminals are easy to operate.
- (6) Suitable for operation in an environment with an altitude of 3000m or less and a temperature of -30°C~55°C (>45°C derating).
- (7) Do not install in a strong magnetic field environment, as far as possible to avoid electromagnetic interference generated by the external environment.

#### **5.1.2 Installation Carrier Requirement**

- (1) It is recommended to build a foundation to install the product.
- (2) Do not mount the equipment to flammable materials. The mounting carrier must be fire resistant.
- (3) The mounting carrier must be reliable and sufficient to carry the weight of the equipment.
- (4) There may be slight vibration during the operation of the equipment. Do not install the equipment on a carrier with poor sound insulation, so as to prevent the noise of the equipment operation from affecting the people in the surrounding area.

### 5.1.3 Installation Angle Requirement

The equipment should be installed horizontally and vertically, not tilted or inverted.

### 5.1.4 Installation Space Requirement



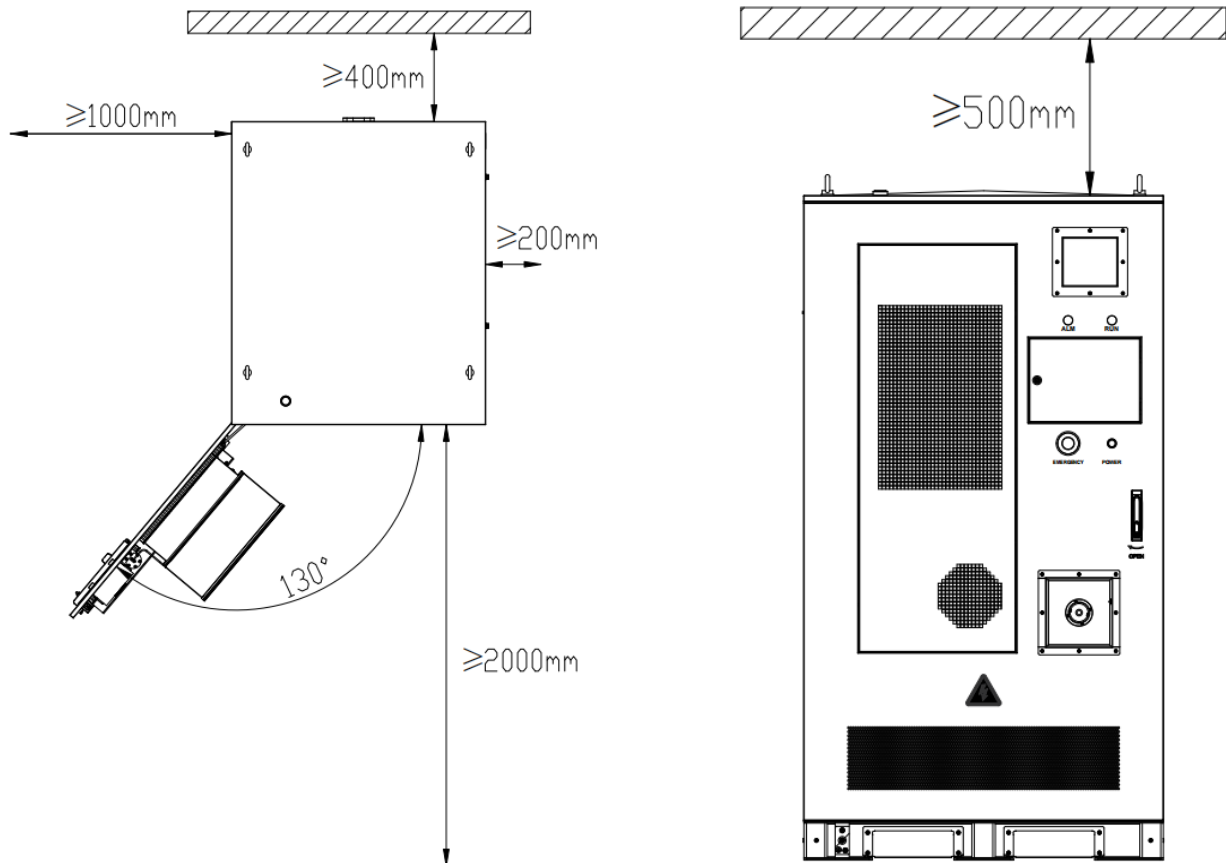

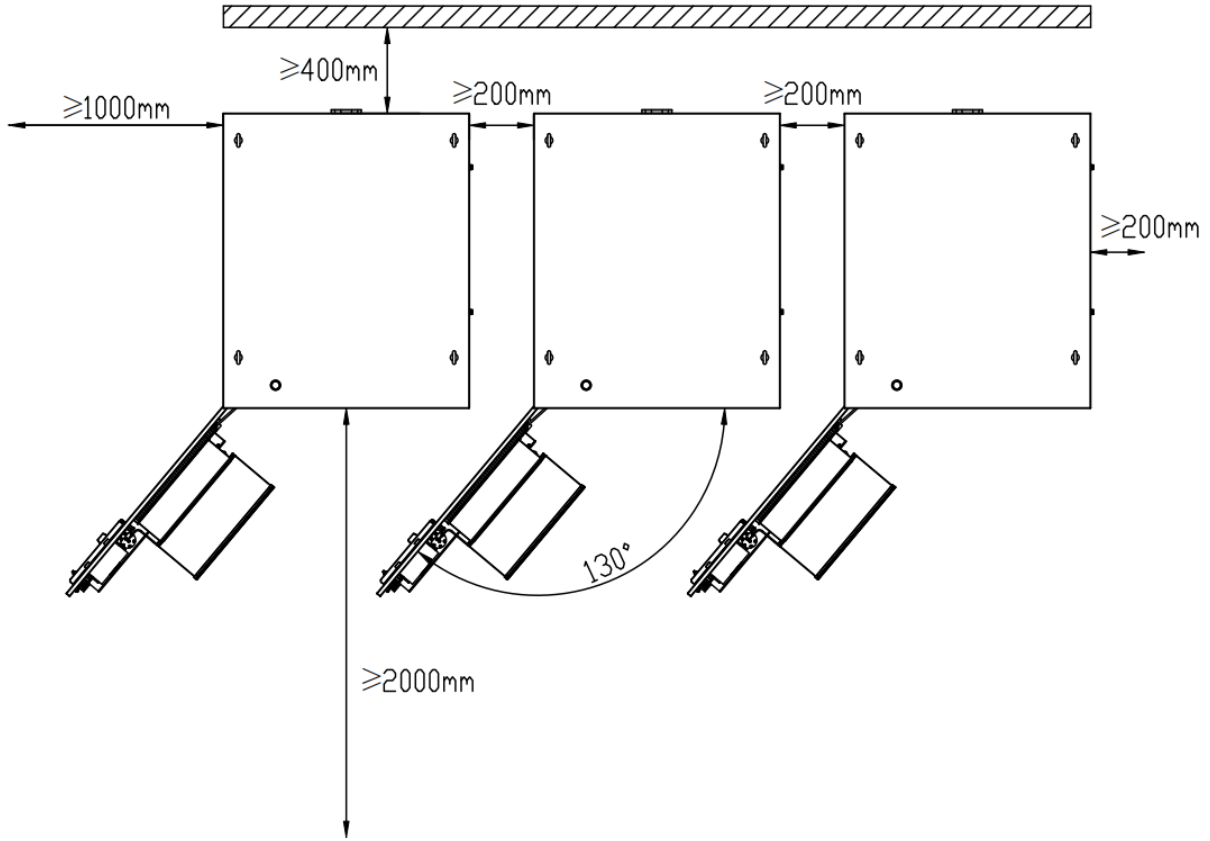
When installing the equipment, please observe the following peripheral space reservation requirements while taking into account the footprint of the equipment:





### 5.1.5 Installation Tool Requirement





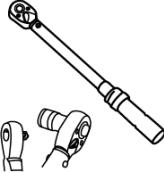
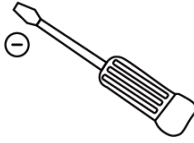
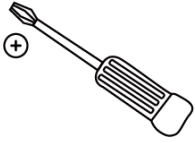

#### (1) Protective Tool

				
Insulated Gloves	Labor Protection Gloves	Safety Helmets	Insulated Shoes	Reflective Safety Jacket

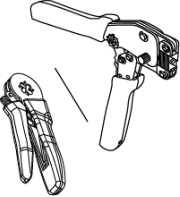
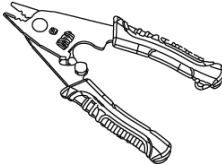
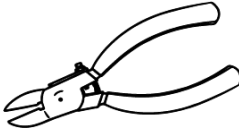
Note: The above is for reference only and is inclusive and not limited to.

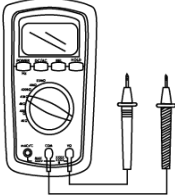
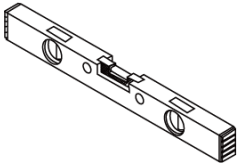
#### (2) Mounting Tool

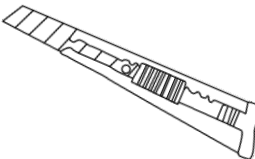
			
Forklift( $\geq 3t$ )	Insulated Torque Wrench (10~50N·m)	Flathaed Screwdriver	Phillips Screwdriver

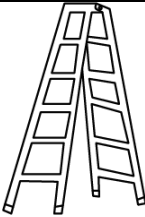
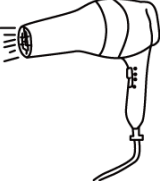
			
Crimping Pliers (7", hexagonal, 0.25~6mm <sup>2</sup> )	Wire Stripper (7")	Wire Cutter (5")	Rubber Hammer (50mm)
			
Multimeter (15B MAX-01, DC1000V)	Level Ruler (500mm)	Steel Tape Measure (5m)	Art Knife
			
Marker Pen	Insulated Ladder (> 2m)	Hot Air Dryer (1600W)	

Note: The above is for reference only and is inclusive and not limited to.

## 5.2 Mechanical Installation

### 5.2.1 Build the Foundation

#### (1) Location selection

When choosing the foundation site, please at least follow the following principles:

The climatic environment and geological conditions (such as stress wave emission and groundwater level) of the installation site of the energy storage integrated system should be fully considered.

The surrounding environment is dry, well-ventilated and far away from flammable and explosive areas.

The soil at the installation site needs to have a certain degree of compaction. It is recommended that the relative density of the soil at the installation site be  $\geq 98\%$ . If the soil is loose, be sure to take measures to ensure the stability of the foundation.

---

## (2) Foundation requirements

An unreasonable foundation construction plan will bring significant difficulties or troubles to the placement, door opening and closing, and later operation of the energy storage integrated system. Therefore, the installation foundation of the energy storage integrated system must be designed and constructed in advance in accordance with certain standards to meet the requirements of mechanical support, cable routing, and later maintenance and repair.

When building the foundation, at least the following requirements should be met:

The bottom of the foundation pit for building the foundation must be filled and compacted.

The foundation should be sufficient to provide effective support for the equipment. The load-bearing capacity of the foundation must not be less than 5 tons.

The foundation should meet the minimum floor area required for the cabinet.

The construction ground should be flat and even without any slope to prevent uneven structural stress or door deformation caused by the tilt of the cabinets.

The construction ground should be designed with a slope or drainage ditches to prevent rainwater accumulation.

The product needs to be installed on a concrete foundation or a structure supported by channel steel with a flame-retardant surface. It is necessary to ensure that the foundation is flat, solid, safe and reliable, and has sufficient bearing capacity.

### **5.2.2 Foundation Construction Method**

Please refer to the following cabinet base structure to complete the planning and construction of the foundation.

Tip:

When the foundation is constructed, pay attention to reserving holes for cable routing. Since most of the cables of the cabinet are thick, it will be difficult to perform cable routing operations once the cabinet is installed. Therefore, lay the power cables before the cabinet is moved to the intended installation location.

When constructing the foundation, pay attention to reserving facilities for the drainage of air

conditioning condensate, with the air conditioning drainage pipes placed inside the foundation. Poor drainage can lead to water accumulation inside the foundation.

Step 1: Construct a concrete foundation. Follow the diagram below to make the foundation, with a recommendation of 200mm above ground and 800mm below ground. The 800mm below ground can be adjusted based on actual survey results, with the depth needing to meet the requirements for cable wiring. Draw the cabinet positioning lines and determine the placement of the cabinets.

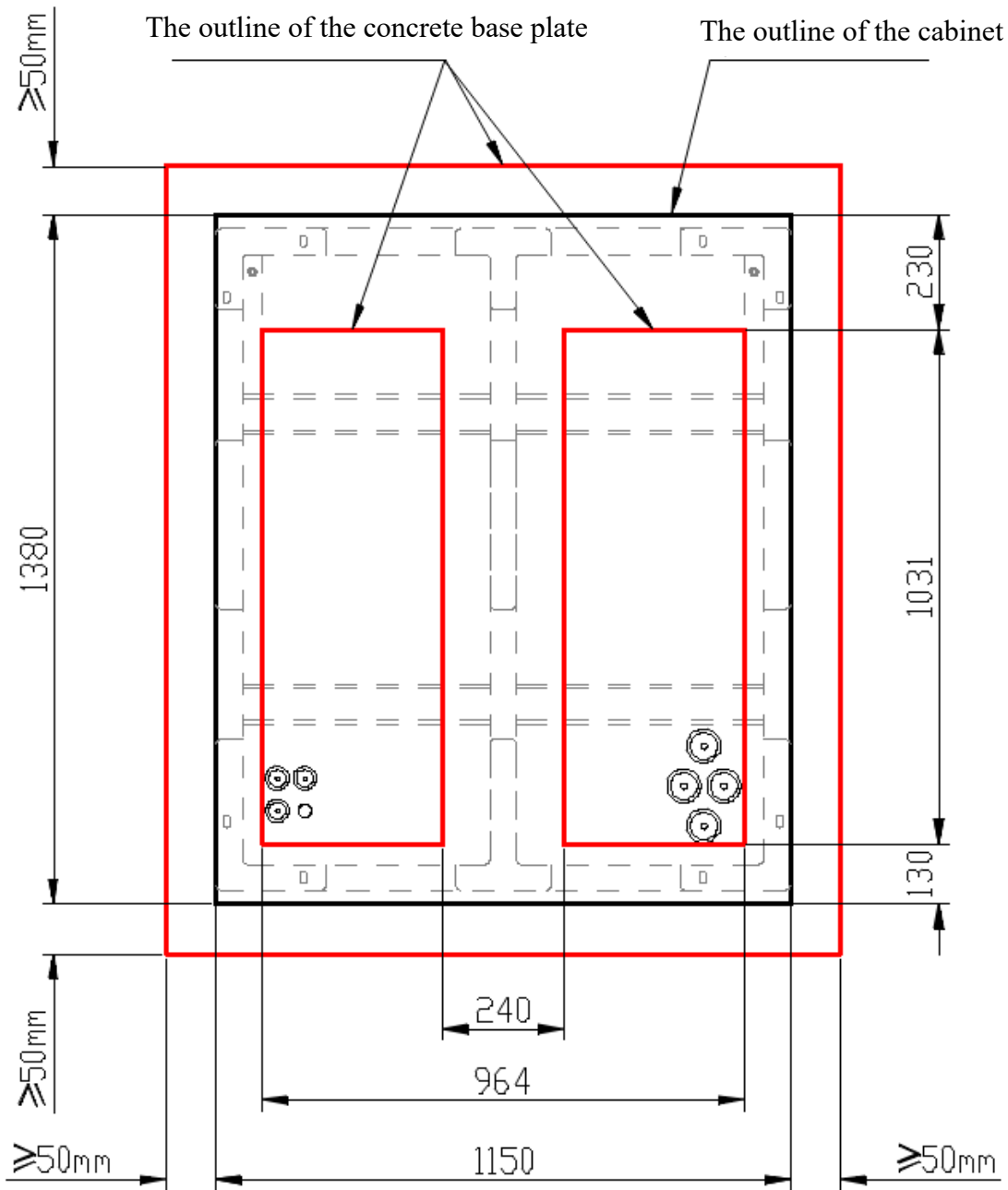

Front door side

Figure 5.2.2.1 Foundation diagram

Step 2: After the foundation is completed, pre-bury expansion bolts, with specifications of M12\*110mm. The expansion tube buried in the concrete should be 0~5mm below the foundation surface to avoid the expansion tube protruding above the foundation, which could cause instability in cabinet installation. First, position the pre-buried hole locations for the expansion bolts. And then forklift transport the cabinet to the concrete base, ensuring uniform space between the cabinet and the concrete base on all sides, placing the cabinet steadily, and using a marker to mark the 8pcs 24\*12 rectangular holes on the cabinet base. After marking, move the cabinet away. Drill holes at the marked locations to place the expansion bolts.

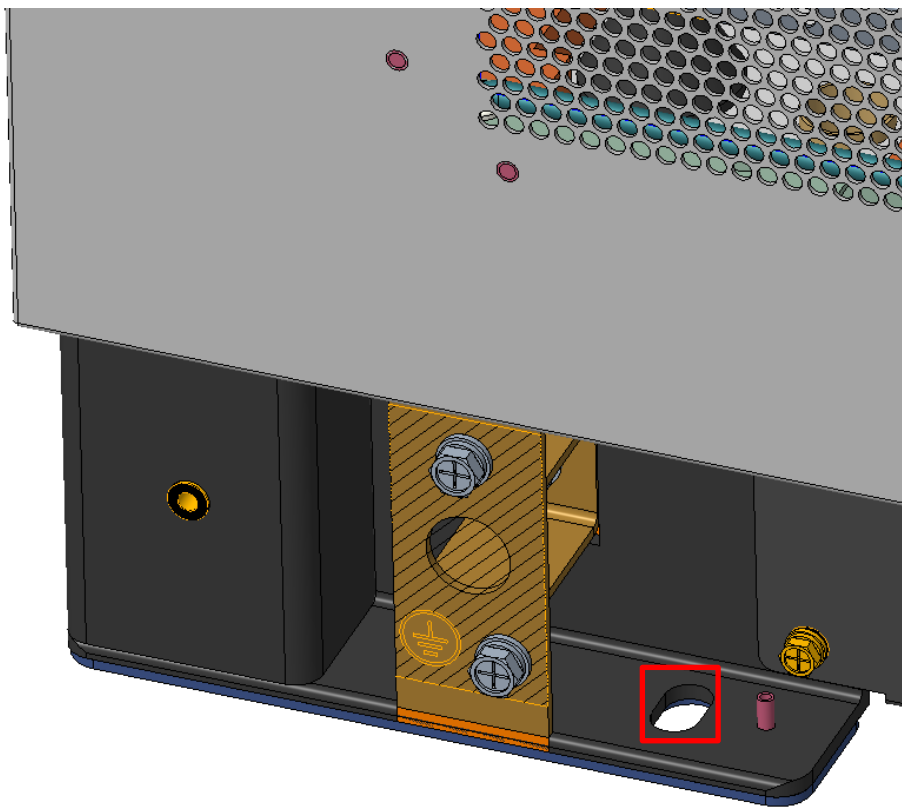

Figure 5.2.2.2 Marker pen marking position diagram

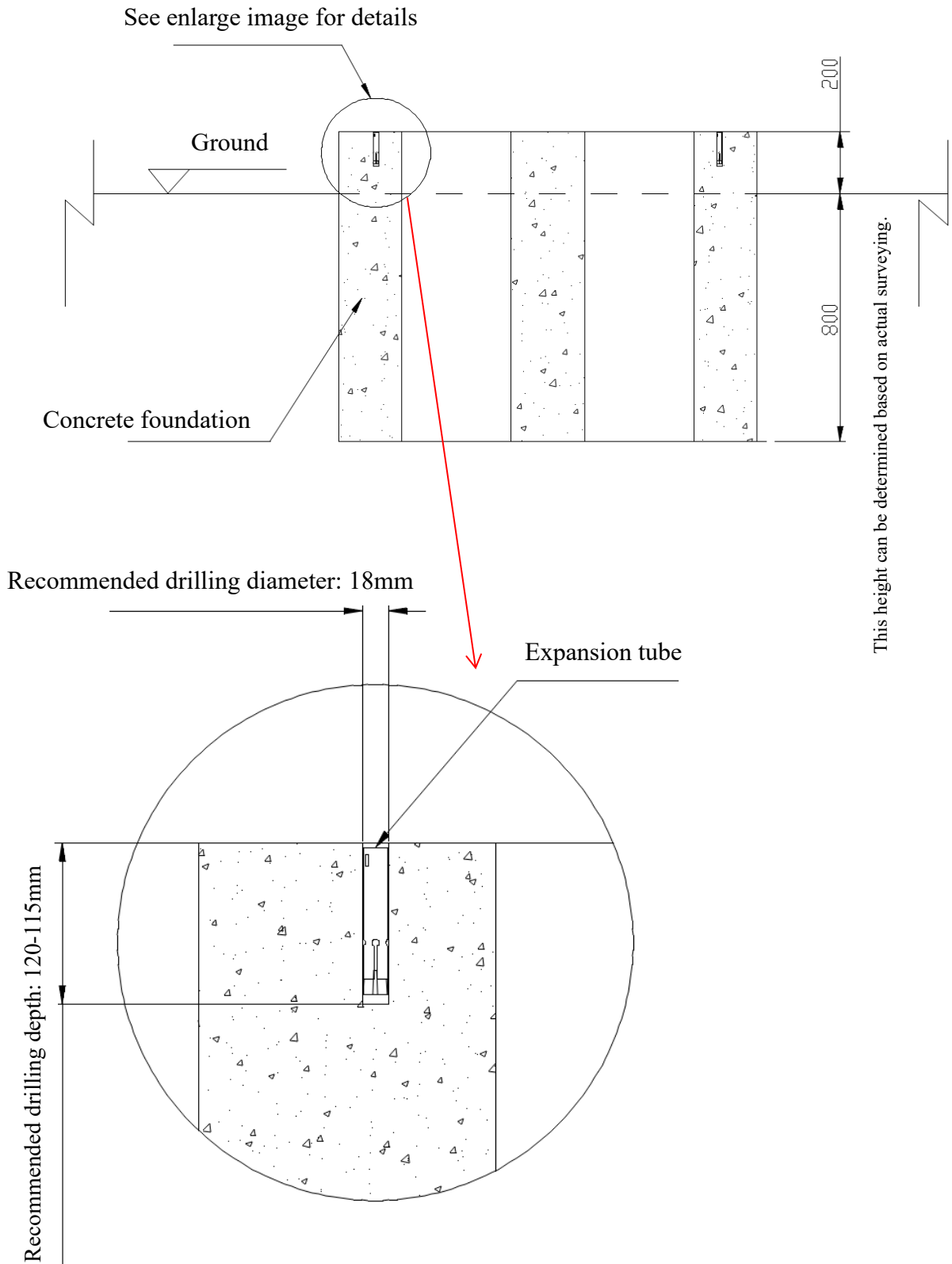
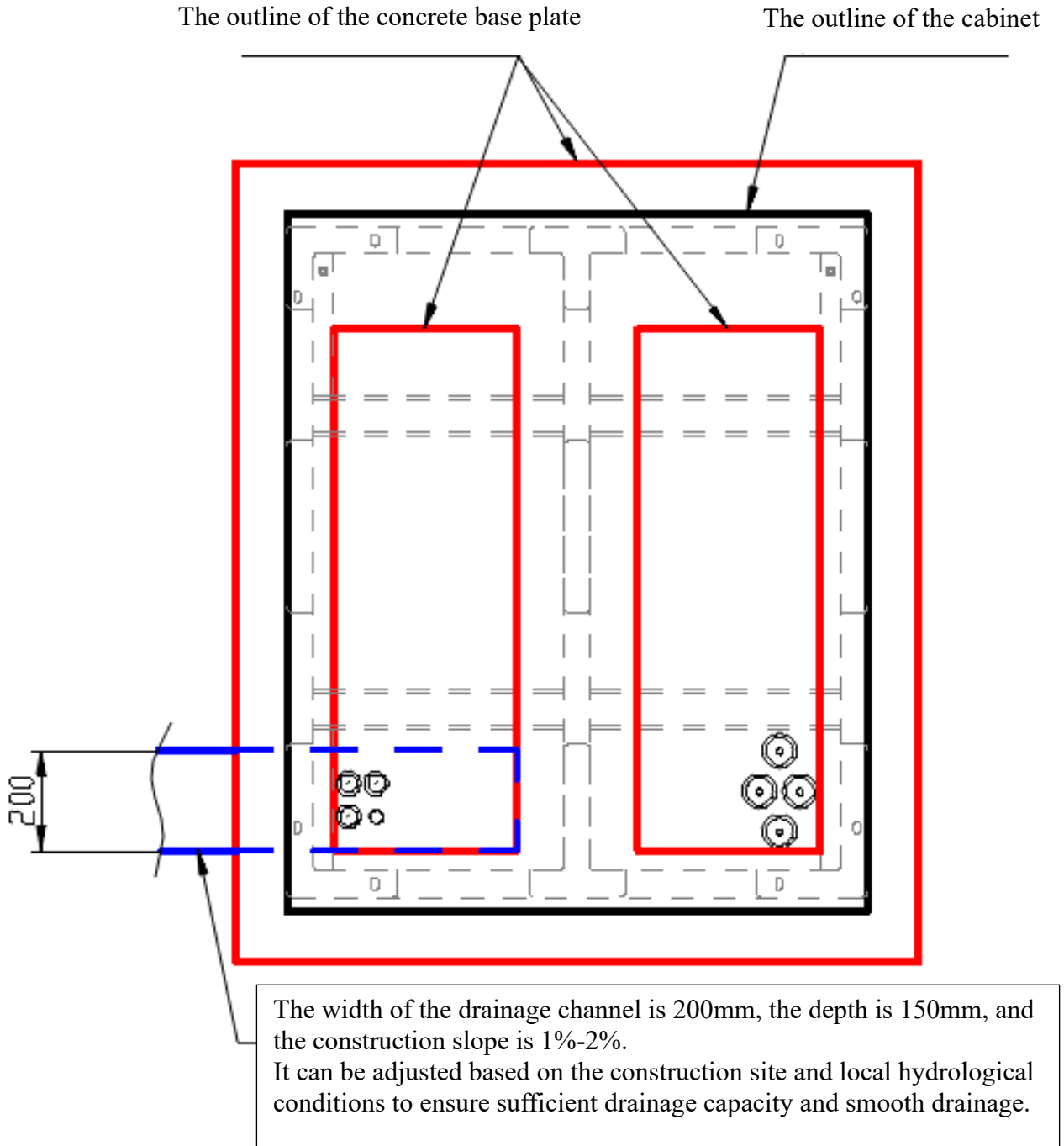

Figure 5.2.2.3 Diagram showing the pre-buried expansion tube

Step 3: Foundation drainage treatment

Air conditioning condensate drainage trough must be effectively isolated from the cable trough. Do not use the drainage trough for cable layout. Drainage trough of construction diagram as follows:



Front door side

Figure 5.2.2.4 Single cabinet drainage trough construction diagram

The outline of the concrete base plate    The outline of the cabinet

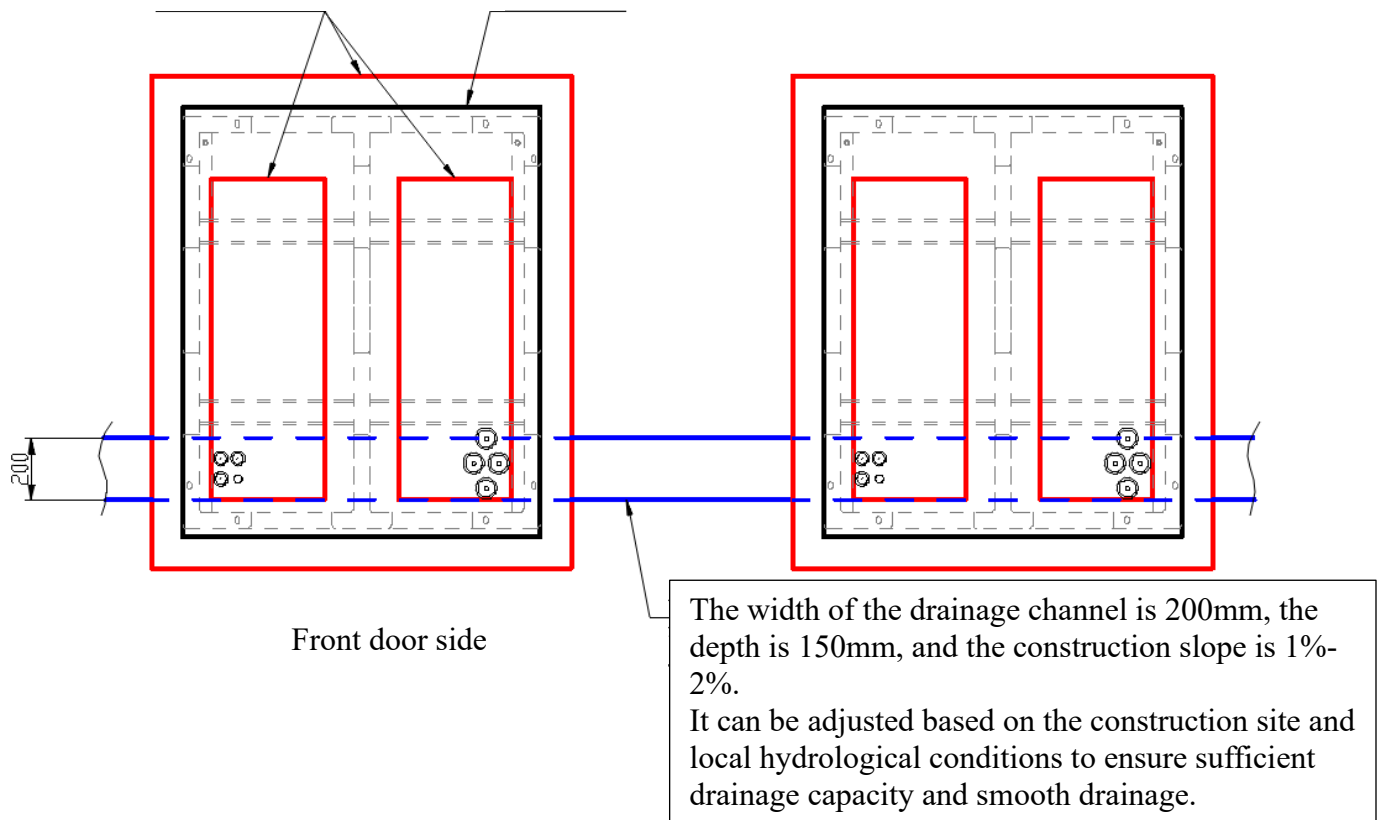

Figure 5.2.2.5 Multiple cabinet drainage trough construction diagram

Construction of the foundation is now complete.

### 5.2.3 Handling Equipment

#### (1) Handling Precautions

##### A. Precautions for lifting and transportation

When lifting the equipment, at least the following requirements must be met:

- Safety must be ensured at the site when lifting.
- When lifting and transportation operations are carried out, professional personnel should be involved and direct the whole process on site.
- The strength of the slings used should be able to withstand the weight of the equipment and a test lift should be attempted before transportation.
- Ensure that all sling connections are safe and reliable, and ensure that the sections of slings connected to corner pieces are of equal length.
- The length of the slings can be adjusted appropriately according to the actual requirements on site.
- Make sure that the equipment is smooth and does not deflect during the whole lifting process.

- 
- Please use the four lifting rings of the equipment to lift the equipment.
  - Make sure that the front and rear doors are locked during the lifting process, and take all necessary auxiliary measures to ensure the safe and smooth lifting of the equipment.
  - The equipment can be lifted from the ceiling using slings with hooks or U-hooks. The lifting device should be properly connected to the equipment.

To move cabinets using lifting devices, special slings should be used, and the strength of the slings should be able to withstand the weight of the product. Before lifting, make sure that the lifting ring is installed tightly, all sling connections are safe and reliable, and make sure that each section of the sling connected to the lifting ring is of equal length to keep the cabinet balanced and avoid tilting of the cabinet resulting in the center of gravity shifting.

When lifting operation, should ensure slow and smooth, should use the tow rope to assist in adjusting the direction of the cabinet to maintain stability. The cabinet must be placed on a solid and flat ground.

During the whole process of lifting operation, relevant safety operation norms must be strictly observed, and it is strictly prohibited for people to stand under the cabinet or on the path that may be tilted.

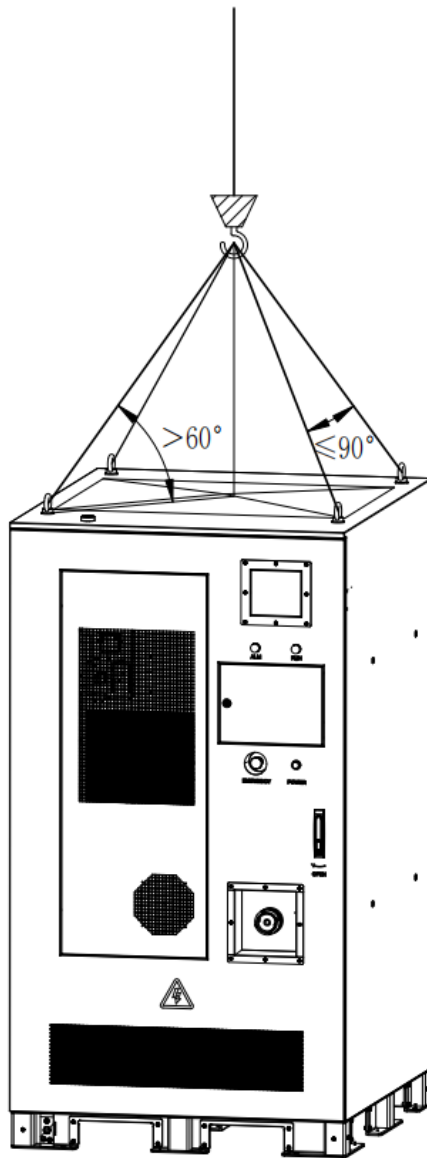

Figure 5.2.3.1 Lifting Schematic

#### B. Forklift Transportation Precautions

If the installation site is flat, the unit can be moved using a forklift. The bottom of the unit is equipped with fork holes designed for forklift transportation. Move the unit through the front fork holes.

If a forklift is used for transportation, the following requirements should be met:

- The forklift should be able to carry the weight of the device, the recommended forklift capacity is  $\geq 3t$ .
- The forklift should have appropriate leg lengths, and it is recommended that a test forklift be used prior to transportation.

- 
- The equipment should be kept stable during the moving process, and should not be moved up and down or tilted too much.
  - Lifting and lowering should be done gently, avoiding shock or vibration, and paying attention to the ground level when moving.
  - Moving should be done by professional personnel, and they should participate in the whole operation command on site.
  - Make sure the front and rear doors of the cabinet are locked before moving to avoid equipment damage or personnel injury.
  - Take all necessary supporting measures to ensure the safe and smooth transportation of the electrical cabinet to the target location.

Using a forklift to move the cabinet is the standard method of transportation. When handling, the center of gravity of the cabinet should fall between the two forks of the forklift and be pre-inserted to ensure that it will not tilt after being fork lifted. The fork length of the forklift should not be less than 2.1m as shown in the diagram.

When using a forklift truck to fork lift, lower and move the cabinet, it should be ensured that it is slow and smooth, and the cabinet must be placed on a firm and flat surface.

In the whole process of using forklift operation, the forklift safety operation specification must be strictly observed. Due to the large size of the cabinet, it may block the driver's vision, there should be auxiliary personnel to cooperate.

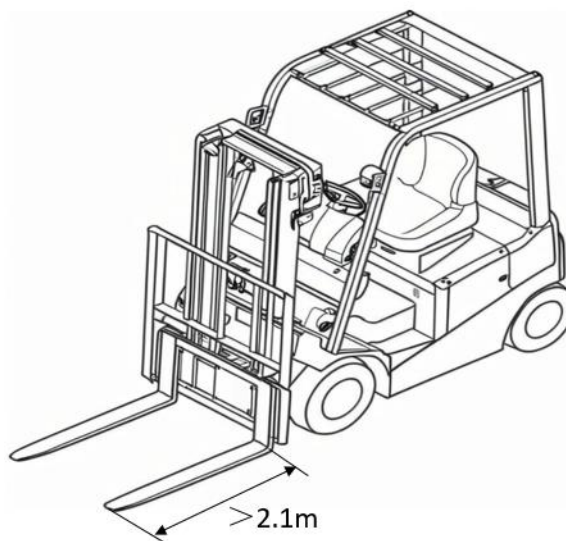

---

### C. Precautions for transportation by pallet

Moving the equipment by pallet is only applicable when the transportation route is relatively flat. When the equipment is moved, its center of gravity should fall between the two forks of the pallet truck and be pre-inserted to ensure that it will not tilt after the fork lift. As shown in the figure, the length of the fork of the pallet truck shall not be less than 1.5m, the two fork arms of the pallet truck, the distance between the outer sides shall not be more than 0.7m, and the load-bearing capacity of the pallet forklift truck shall be more than 3t.

The use of pallet truck forks up, down and move the equipment, should ensure that slow and smooth, the equipment must be placed on a solid and flat ground.

In the whole process of using pallet truck operation, the relevant safety operation specification must be strictly adhered to. Due to the large size of the equipment, the operator's vision may be obscured, and should be accompanied by auxiliary personnel.

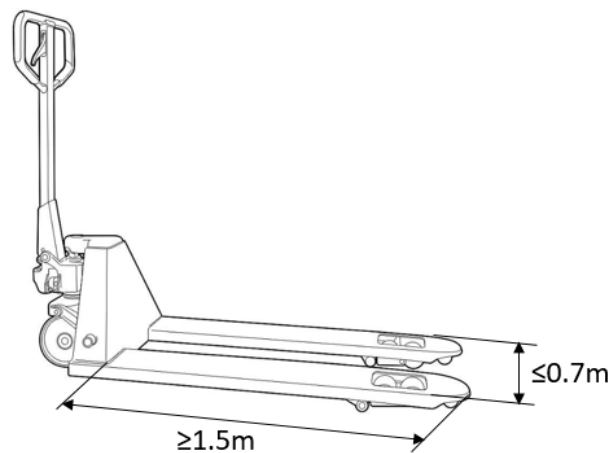

### 5.2.4 Installation Method

(1) After the foundation is completed, proceed with cabinet installation. First, lay all required wiring cables in the trenches. Refer to Section 5.3 for details on which cables need to be connected.

(2) Once the cables are pre-embedded, install the cabinets onto the constructed foundation. Position them according to the cabinet alignment lines marked on the foundation, ensuring alignment with the pre-embedded expansion bolts.

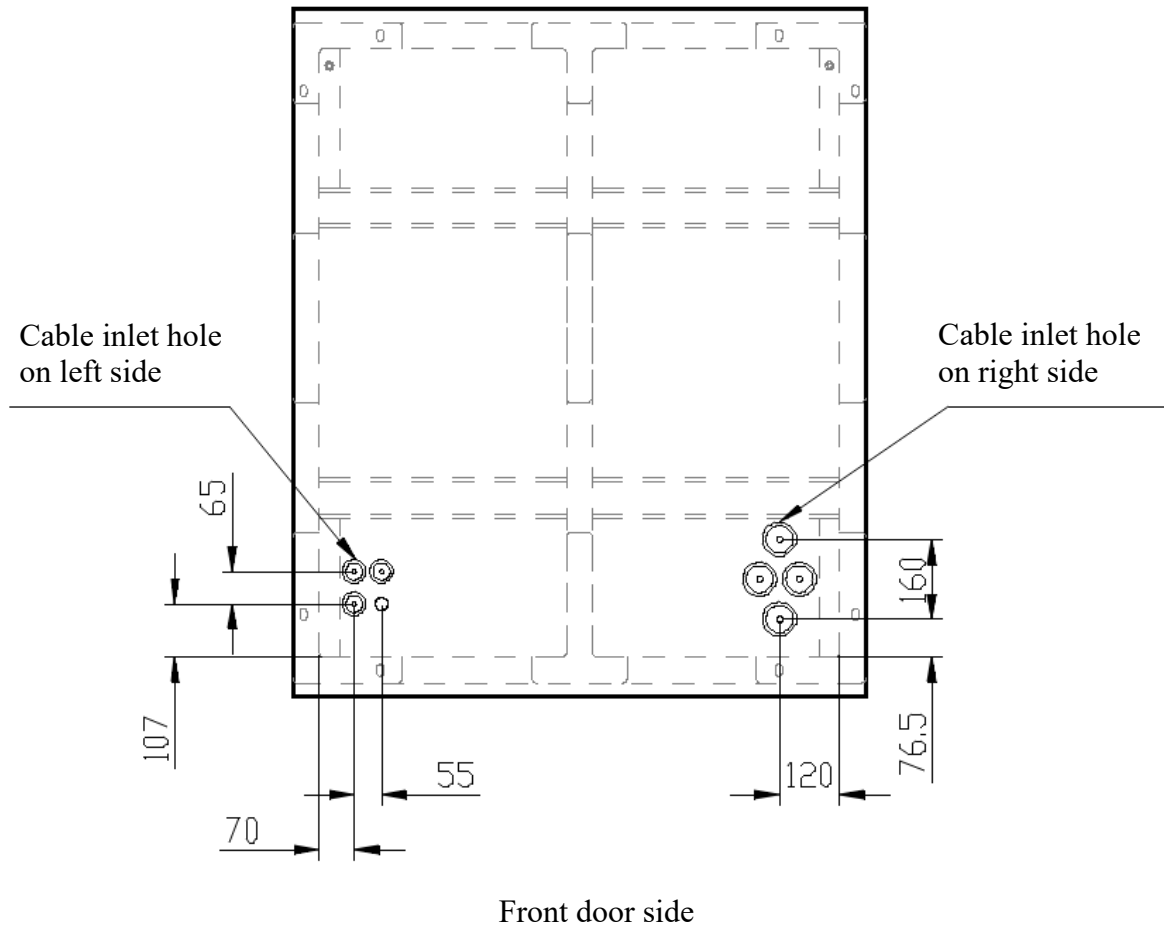

Figure 5.2.4.1 Cabinet bottom placement position diagram

(3) After the cabinets are placed, start connecting the cables. The left and right sides of the cabinet bottom are reserved for the secondary and primary cable inlet holes, as shown in the following figure.

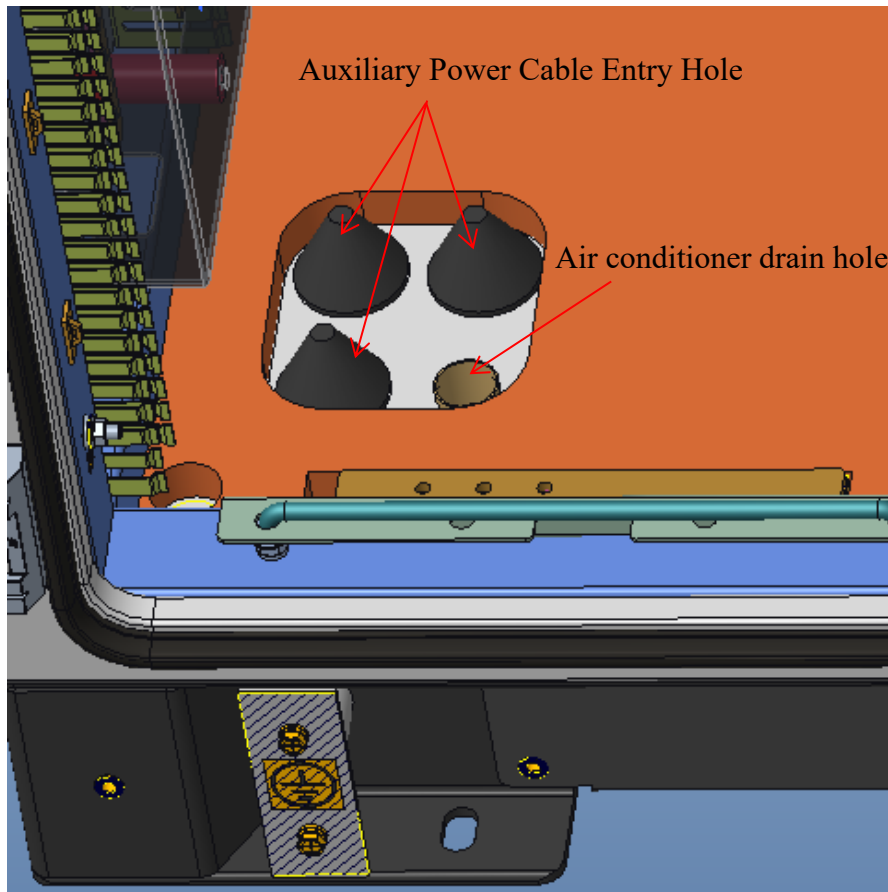

Figure 5.2.4.2 Cabinet bottom left secondary line inlet hole diagram

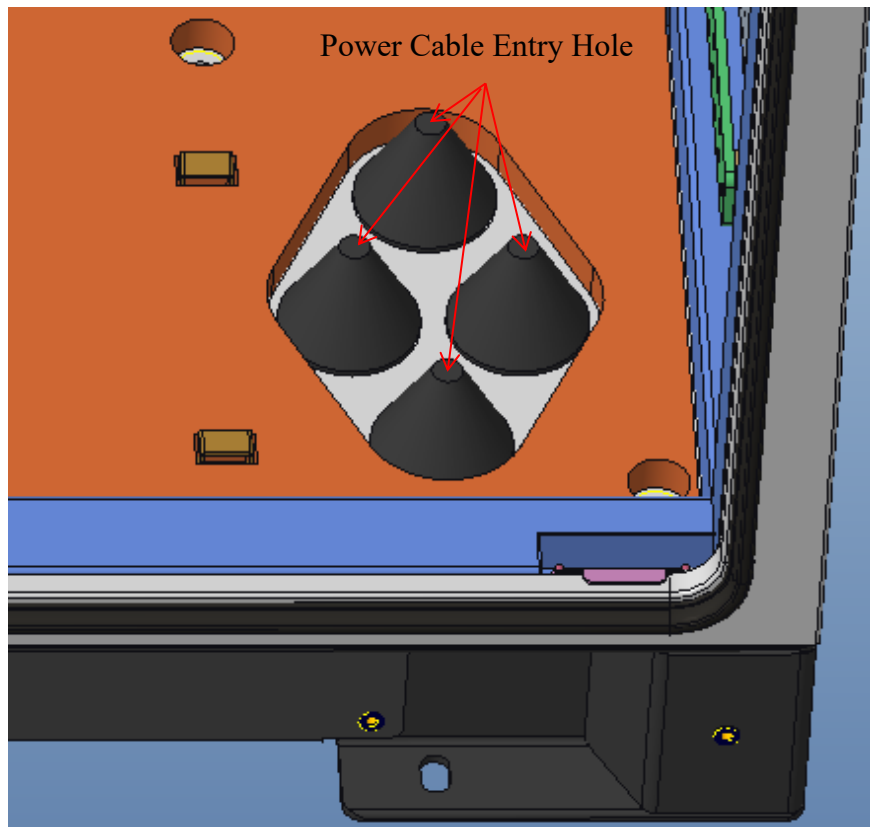

Figure 5.2.4.3 Cabinet bottom right primary cable inlet hole diagram

---

Based on the cable diameter, use a utility knife to make a ring cut at the appropriate position on the tower-type cable guard to remove the excess part.

The tower-type cable guard cutting diagram:

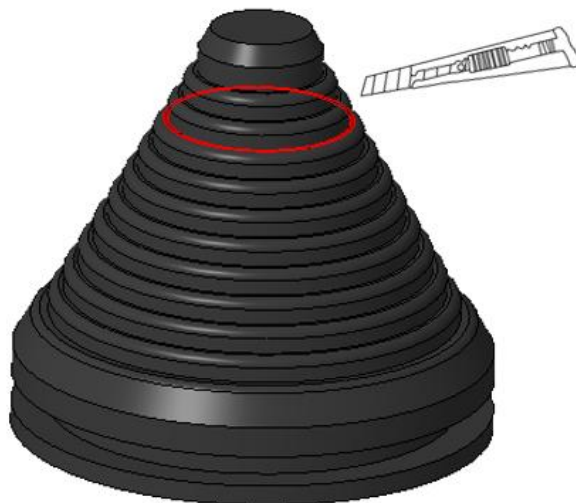

Figure 5.2.4.4 Schematic Diagram of Tower-Type Cable Protection Ring Cutting

### 5.2.5 Fixed Equipment

After completing the threading steps, it can start to fix the cabinet.

(1) Align the installation holes of the cabinet base (on the ground) with the expansion pipes embedded in the concrete (complete this step when placing the cabinet) and tighten the expansion bolts (A total of 8pcs) . As shown in the figure below:

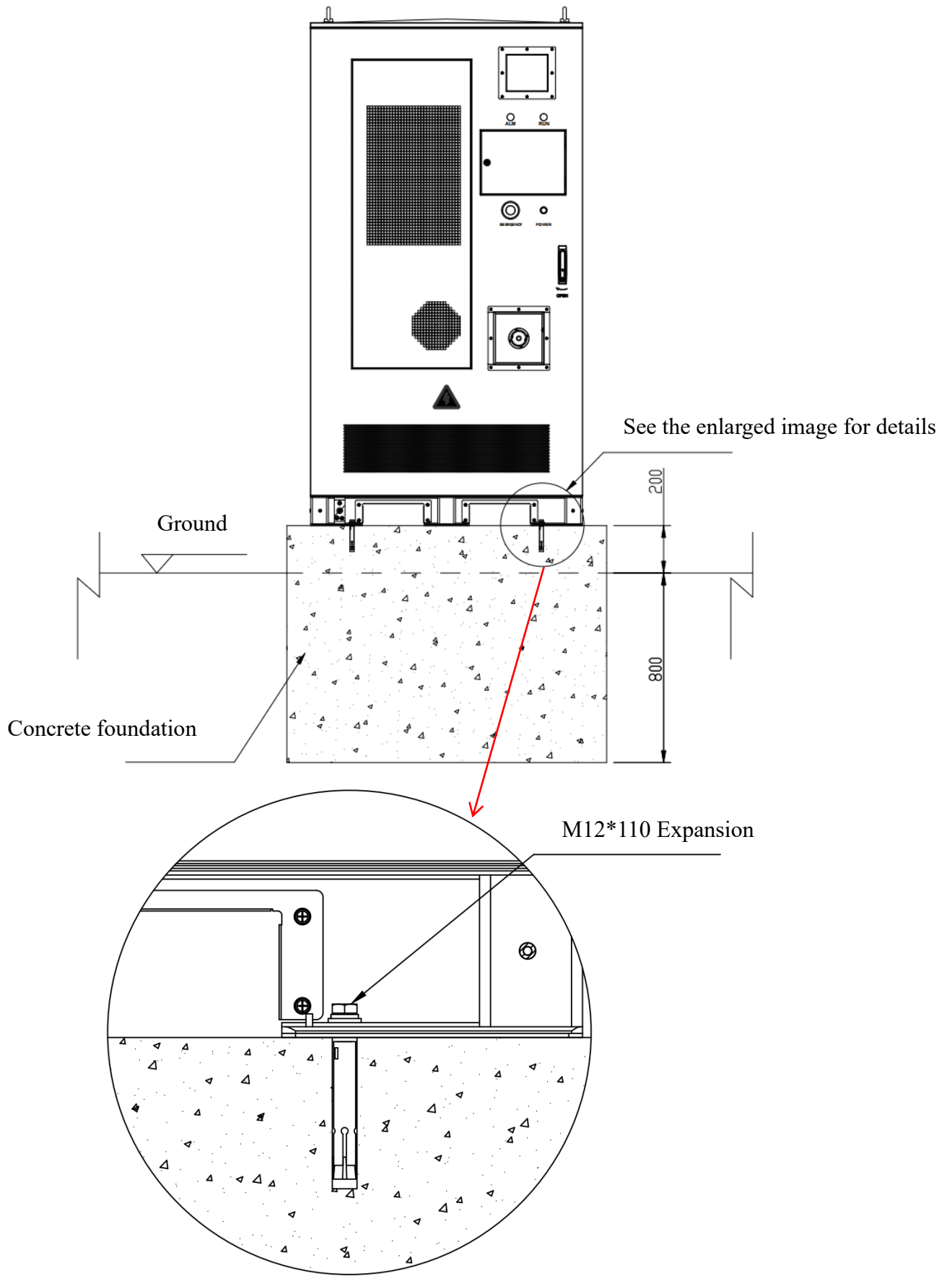
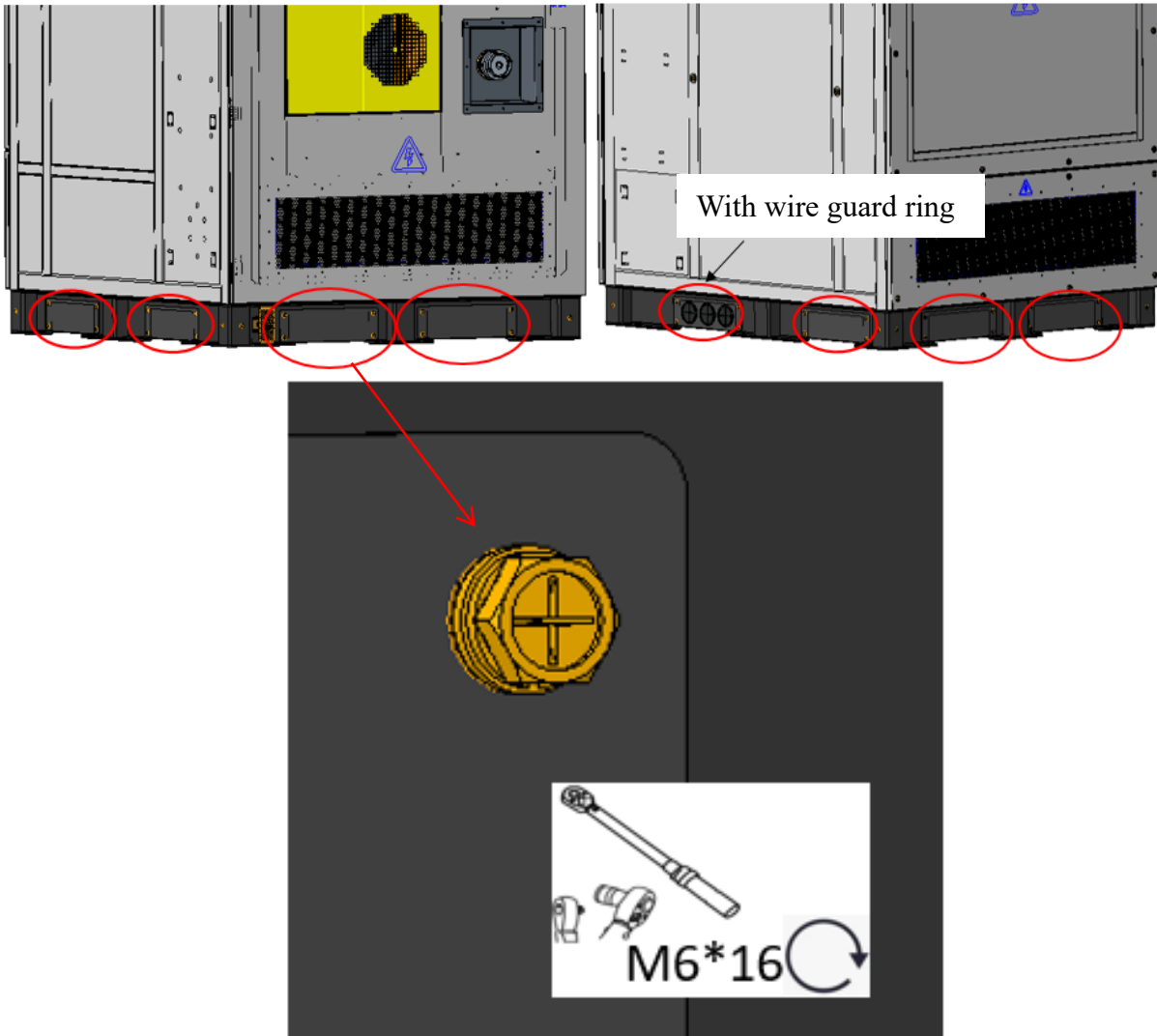

Figure 5.2.5.1 Bolting Fixing Schematic

(2) Install base panel

First remove the perimeter bumper panels (screws, unscrew counterclockwise), then install the base surround panels in their original positions.

Panels need to be installed on the front, back, left, and right sides of the cabinet, except for the panel with cable guard near the front door on the right side of the cabinet. The structures of the panels in other positions are the same. Each panel is fixed with 4pcs M6\*16 bolts (Recommended torque: 5N•m).



Note: When the on-site wiring does not run through a cable trench, it can be routed from the bottom of the cabinet through this the wire grommet for wiring. Base on the cable size, cut an appropriate size in the wire grommet. After cutting the slot, pass the cable through and connect it to the internal part of the cabinet.

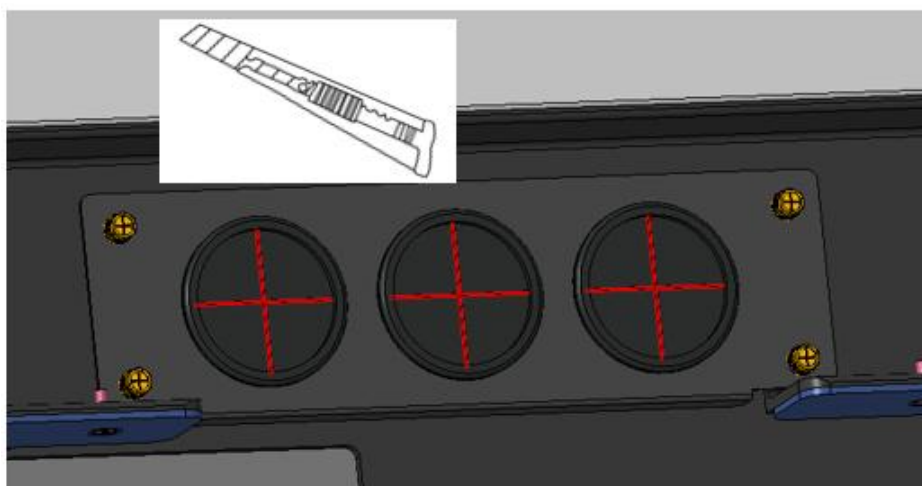

Figure 5.2.5.2 Schematic Diagram of Enclosure Cable Protection Coil

## 5.3 Electrical Wiring

### 5.3.1 Wiring Precautions

**⚠** When connecting the wires, please make sure to complete them in order according to the contents of the manual, the ground connection must be completed first, and all the wiring work must be carried out in a no-voltage state. Before connecting the electrical cables, please make sure that the control box air switch, AC side air switch, miniature circuit breaker and all higher level switches are disconnected.

### 5.3.2 Wire Harness Specification

NO.	Wire Harness Name	Recommended wire harness specification (minimum cross-sectional area)	Terminal Specification	Note
1	Grid to equipment power lines (A/B/C/N lines)	70mm <sup>2</sup>	OT terminal M8/M10	Cables to be provided by the customer
2	230V auxiliary power supply line (L/N line)	8AWG (8mm <sup>2</sup> )	OT terminal M6	Cables to be provided by the customer
3	Ground wire	50mm <sup>2</sup>	OT terminal M8	Cables to be provided by the customer
4	Communication lines with higher-level EMS	Ultra Category 5 Shielded Cable	/	If required, customer to provide

Note: Cable specifications should be selected in accordance with local cable standards. Factors

affecting the selection of cables include: rated current, cable type, laying method, maximum expected line loss, rated temperature, ambient temperature, temperature resistance, acidity, settlement, environmental protection requirements and so on.

Screw Specification	Recommended Torque
M6	$5 \pm 10\%N \cdot m$
M8	$12 \pm 10\%N \cdot m$
M10	$26 \pm 10\%N \cdot m$

### 5.3.3 Ground Line Connection

The system's internal ground wire is connected at the time of shipment; the system's external ground wire must be connected manually on-site. Please refer to the local regulations to connect the external ground wire before wiring. Take out the ground wire (provided by the customer, wire diameter not less than  $50\text{mm}^2$ ), use M8\*20 screws to crimp one end to the outside of the cabinet, the specific crimping position see the following figure. The ground wire can be connected in series when paralleling cabinets.

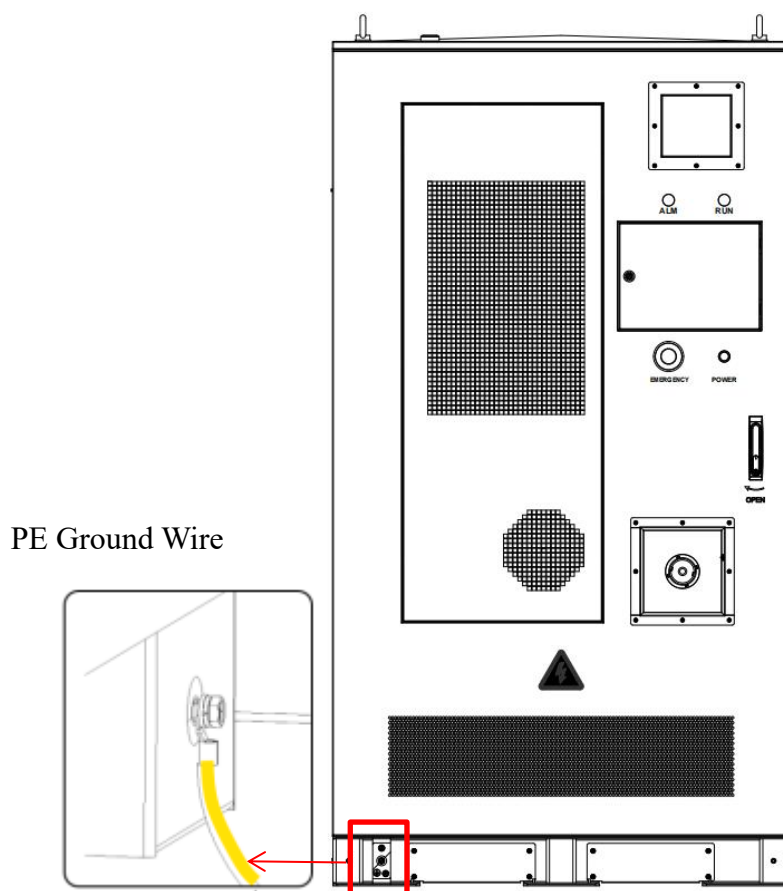

Figure 5.3.3.1 Schematic Diagram of Ground Wire Connection Position

### 5.3.4 Power Line Connection

The power line (provided by the customer) is mainly connected through the copper row, the lead power

line through the bottom of the front door of the cabinet three-phase and single-phase routing holes, three-phase power grid cable threading holes in the lower right corner of the cabinet, take M8 \* 20 screws crimp power line to the cabinet internal copper row; single-phase auxiliary power supply cable threading holes in the lower left corner of the cabinet, take M6 \* 16 screws crimp the power line to the cabinet internal copper row. Please do not connect the wrong way: please connect strictly according to A \ B \ C \ N (three-phase four-wire system) or L \ N (single-phase two-wire system) to distinguish between positive and negative copper row. The diameter of three-phase cable is not less than 70mm<sup>2</sup>, and the diameter of single-phase cable is not less than 8mm<sup>2</sup>.

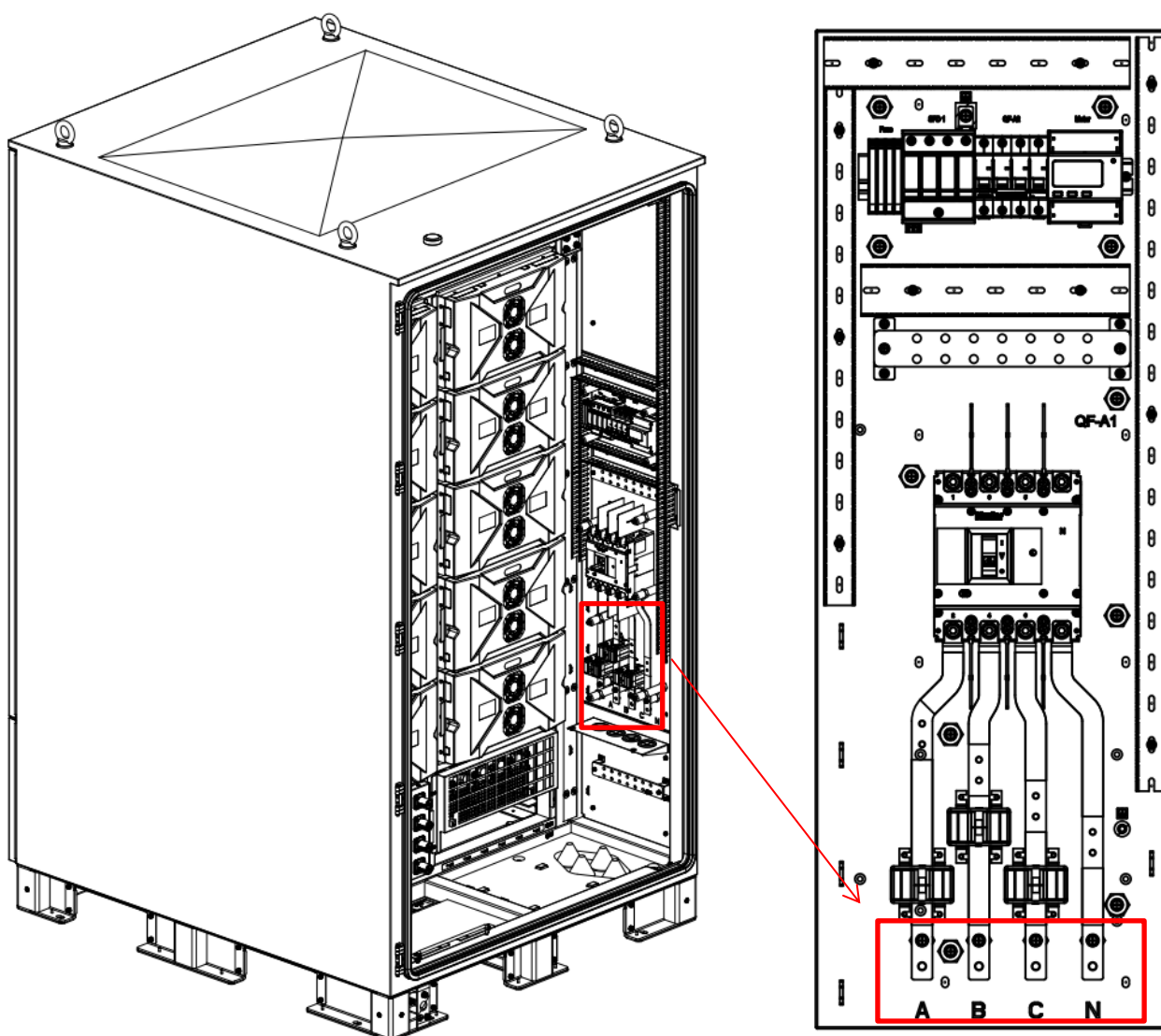

Figure 5.3.4.1 Schematic Diagram of Power Cable Connection Locations

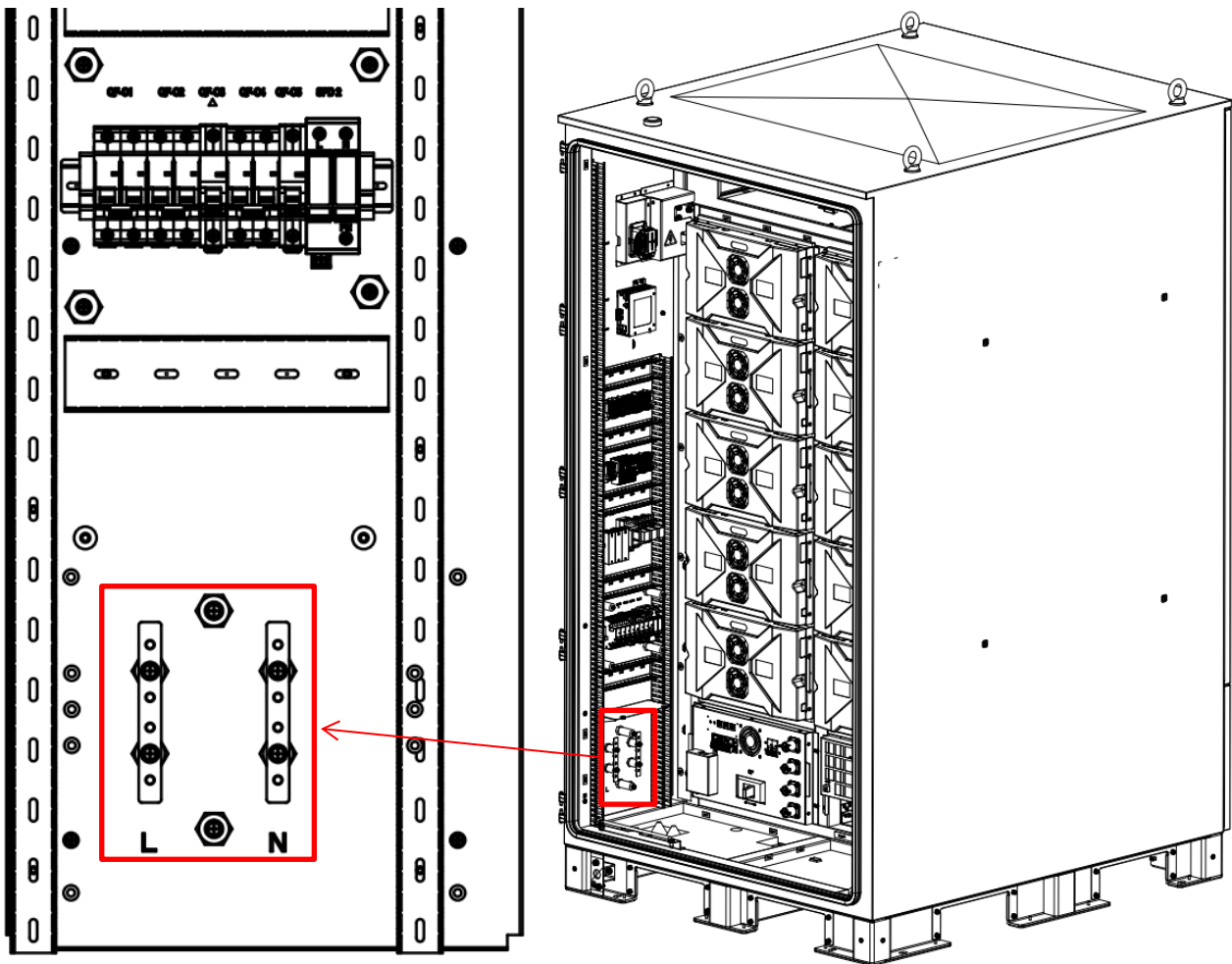

Figure 5.3.4.2 Schematic Diagram of Auxiliary Power Cable Connection Locations

### 5.3.5 Communication Line Connection

The internal communication cable of the system has been connected when it is shipped, and the external communication cable of the system (provided by the customer, recommended super 5 shielded cable and above) can be connected to the SPD IN end of the network port lightning protector as required, the position of which can be seen in the following figure. The terminal port of the LAN/WAN communication cable is on the Fuda Cloud Data Box, and the default connection is from the LAN port to the PC via the SPD2 to carry out the debugging of the equipment locally and the operation of the network distribution, etc.; the user can also connect the WAN port to the router to connect the data module with the IOT cloud platform via wired method. Users can also connect the WAN port to the router, which can be wired to the data module to connect the main cabinet to the IOT cloud platform. SPD3 is reserved for parallel operation communication and is only used when multiple battery cabinets are connected in parallel.

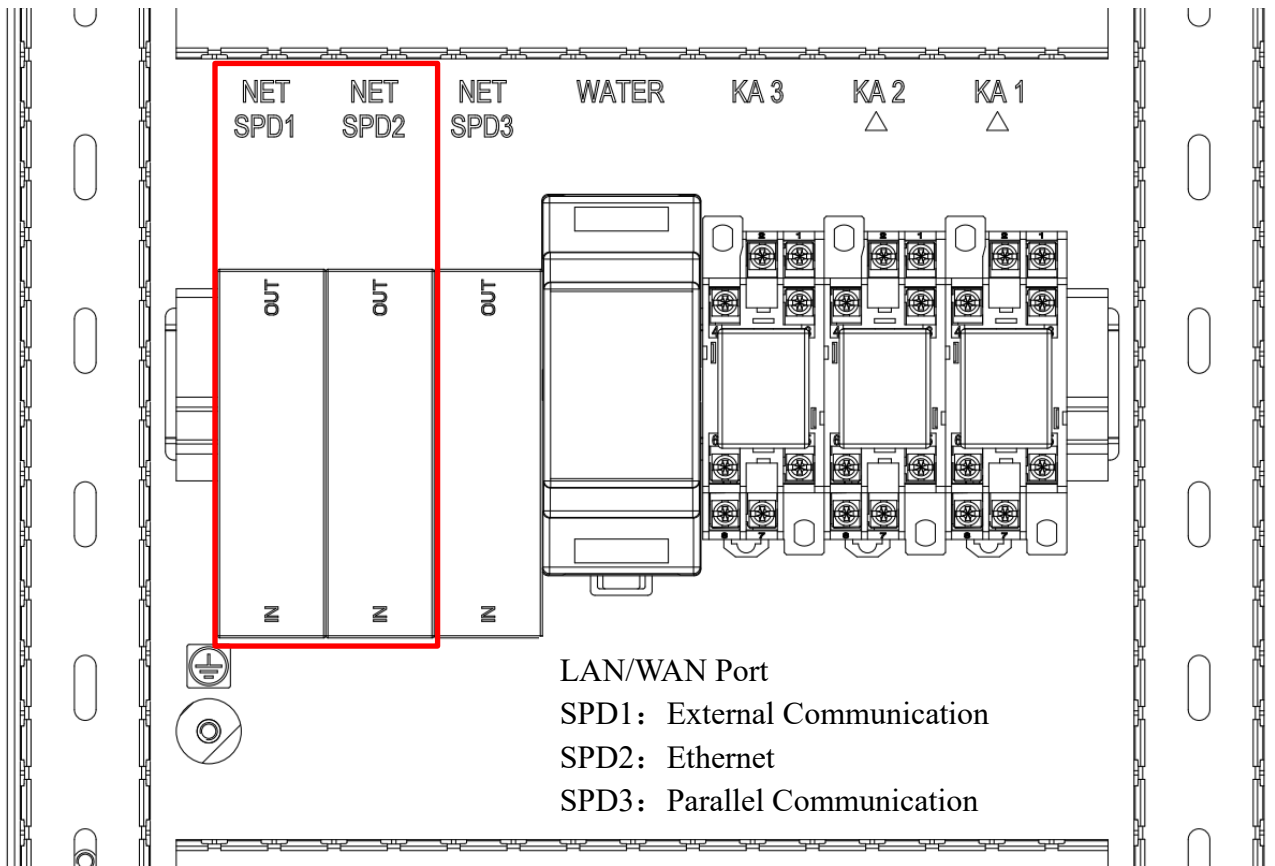
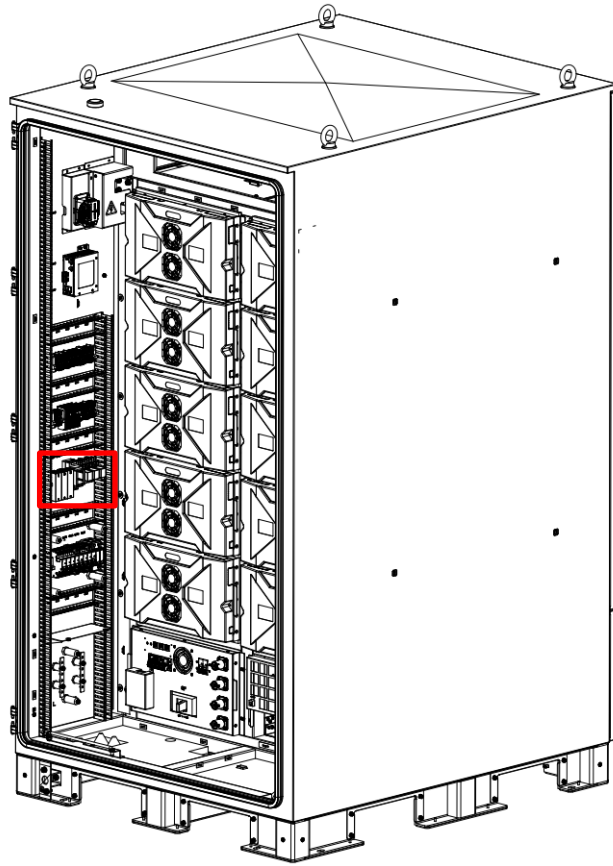

Figure 5.3.5.1 Communication Wiring Location Diagram

---

## **5.4 Installation Inspection**

### **5.4.1 Electrical Inspection**

(1) Ground wire connection is complete. Connection is tight and secure, no leakage, wrong connection.

(2) Power line connection is complete. Connect firmly and securely, without polarity reversal, leakage, wrong port and other phenomena.

(3) The communication line is connected correctly. Connection is tight and reliable, no leakage, wrong connection.

(4) The cables meet the principle of separation of strong and weak power, and the alignment is straight and smooth, without crossing.

(5) All cables are not damaged or cracked, reasonably distributed, with appropriate margins at the turns.

(6) Check the value of grounding resistance ( $<4\Omega$ ) and make sure that the ground wire is well connected to the ground network.

### **5.4.2 Structural Inspection**

(1) The equipment is well installed and free from breakage, rust and paint loss. If so, please refill the paint in time.

(2) Equipment label is clearly visible. If it is broken, please replace it in time.

(3) The equipment is firmly and stably installed, and the surrounding space meets the requirements.

(4) The equipment surrounding is clean and tidy, and there is no construction leftovers inside the equipment.

(5) The protective cover and baffle plate removed during wiring have been re-installed, and there is no missing installation.

---

## VI. Equipment Operation

### 6.1 Indicator Light Introduction

#### 6.1.1 Cabinet Indicator Light

NO.	ALM	RUN	Note
1	OFF	Flickering	The system is powered on for self-check
2	OFF	Always on	The system is operating normally.
3	Always on	OFF	The system is faulty (unable to operate).
4	Always on	Always on	System debugging mode

#### 6.1.2 Control Box Indicator Light

NO.	ALM	RUN	Note
1	OFF	Flickering	The battery cluster is powered on for self-check
2	OFF	Always on	The battery cluster is operating normally
3	Always on	OFF	The battery cluster is faulty (unable to operate).

### 6.2 Operation Guidance

#### 6.2.1 Pre-operation Inspection

1) Before proceeding to the next step of powering up the equipment, please read carefully “I. Safety Statement” of this manual and make a detailed inspection.

2) When operating or maintaining the internal metal parts of the equipment, the voltage to the enclosure (protective ground) must be checked with a high-voltage tester or other instrument to prevent electric shock.

After the installation of the equipment is completed, you need to check the following contents carefully and item by item before applying the power:

1. Please read “I. Safety Statement” carefully.
2. Confirm that the equipment is not damaged, scratches and other signs.

3. To confirm that the equipment cabinet, cabinet tops without leaving foreign objects.
4. Confirm that there is enough space around the equipment for maintenance and operation.
5. To confirm that there is no explosive, flammable materials around the equipment.
6. Confirm that the system input switch in the field is disconnected, all the power wiring is correct, all the communication line cable connection is correct.
7. Confirm that the equipment has been well grounded.
8. Confirm that the equipment has been set up around the isolation zone and warning signs to prevent others from misuse or close.

### 6.2.2 Power-up Procedure

Before powering on, ensure all cables mentioned above are properly connected. After verification, power on the DC circuit first, followed by the AC circuit. The recommended power-up sequence is as follows:

- 1、 Connect the MSD maintenance switch of the DC circuit.

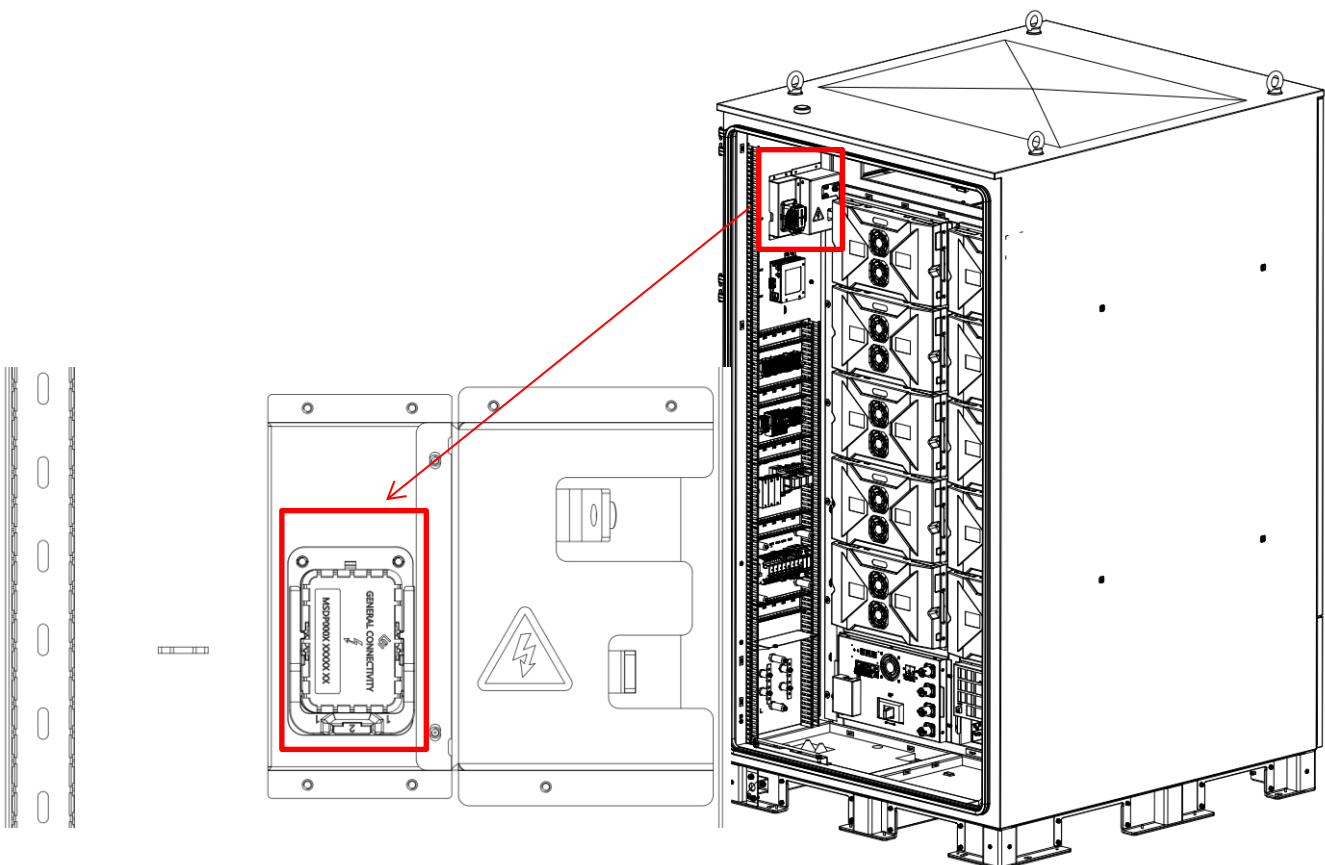
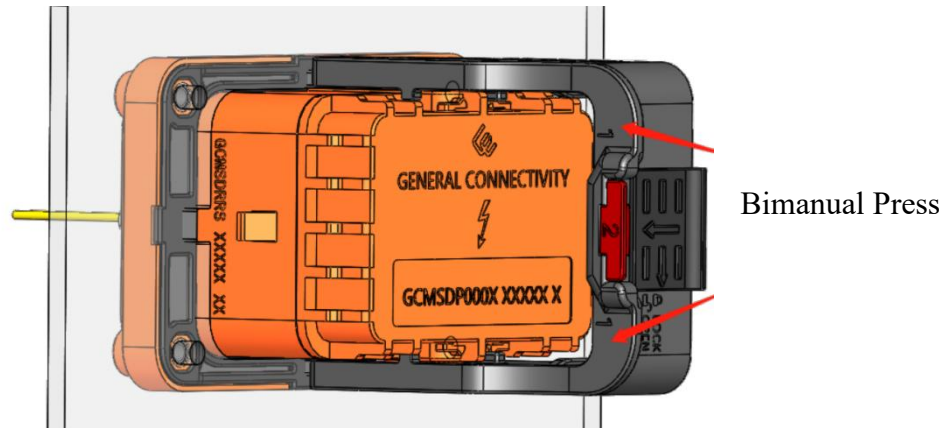
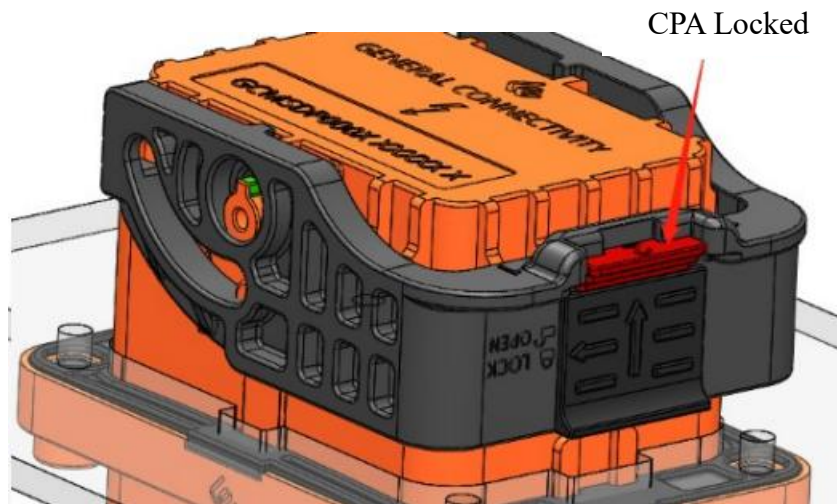

Figure 6.2.2.1 Schematic diagram of the maintenance switch



MSD plugs and sockets are designed for mutual compatibility. With the CPA in the open position, simultaneously press down on handle “1” of the MSD. Upon hearing a “click,” the handle is fully locked.



After the handle is fully locked, press down on the MSD CPA. Push the CPA until the unlocking slider is flush, achieving the secondary locking effect of the MSD CPA.

2、 Close the high-voltage control cabinet circuit breaker, the DC main circuit breaker QF.

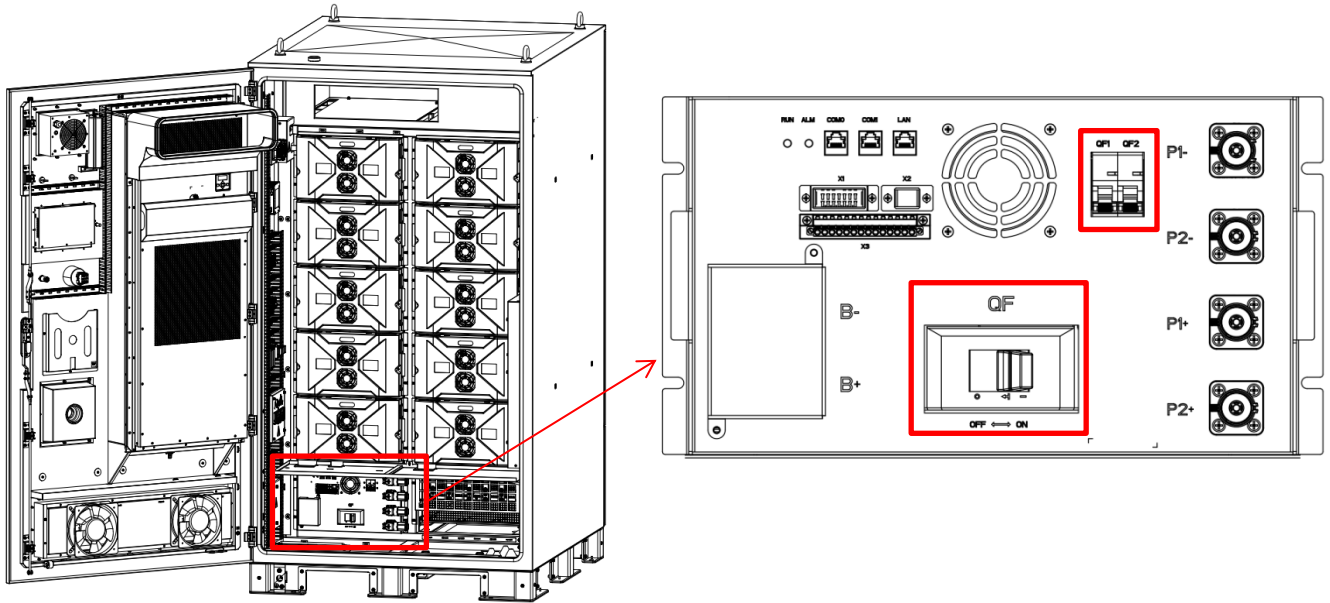
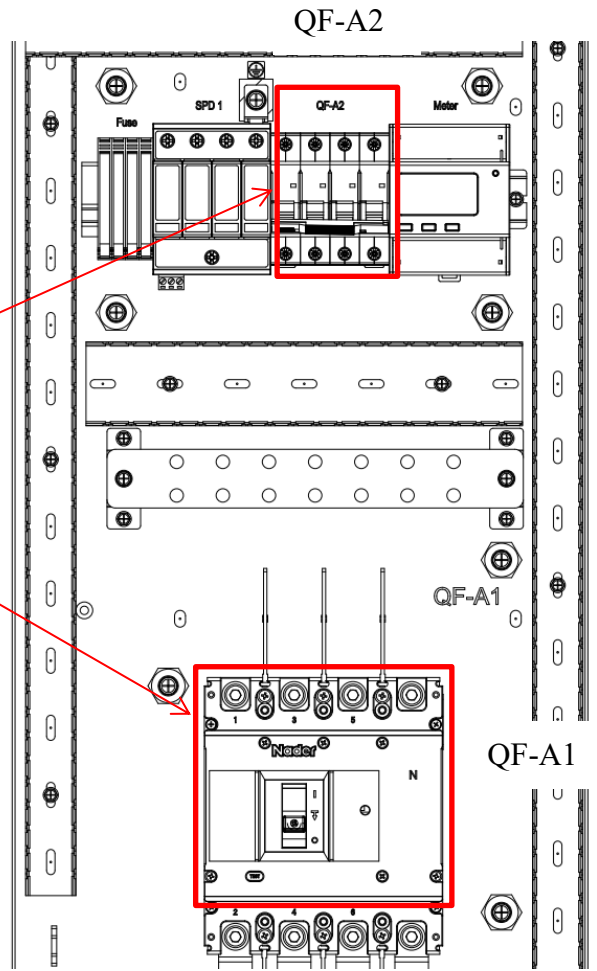
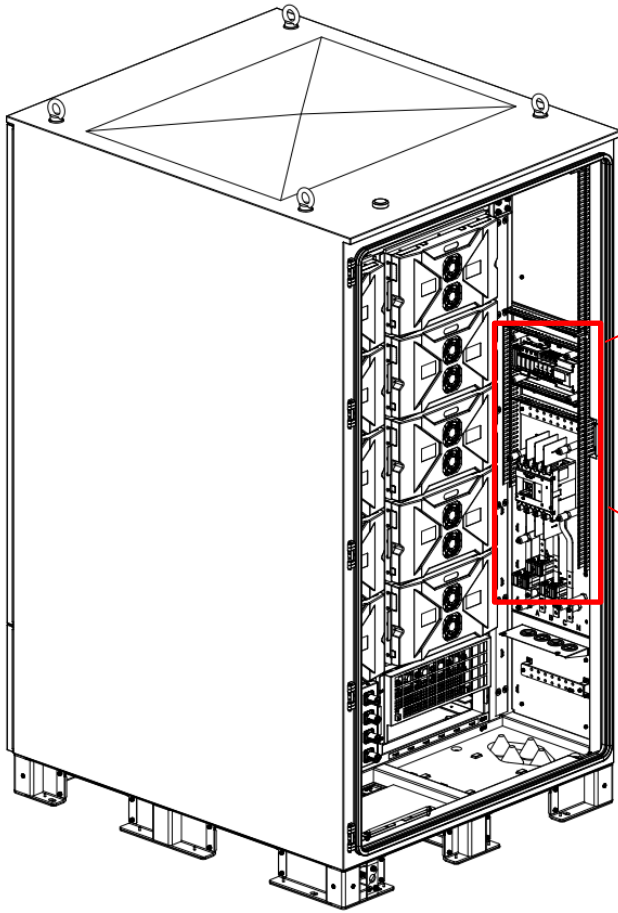

Figure 6.2.2.2 Schematic diagram of the control box

3、 Press and hold the POWER button on the cabinet door for 3 seconds. The DC side will be powered on, and the RUN indicator lights on the control box and the cabinet will display green. Complete the DC circuit power-up.

4、 Wait for the system self-test to complete until the positive and negative pole contactors K in the LCU screen close, and simultaneously hear the sound of the contactors closing. Then close the auxiliary power circuit breakers QF1 and QF2 in the high-voltage control cabinet.

5、 Close the following switches within the cabinet: Grid protection switch (QF-A1), Grid-side surge protector switch (QF-A2), AC auxiliary power supply switch (QF-C1), Auxiliary power surge protector switch (QF-C2), Fan power supply switch (QF-C3), air conditioning power supply switch (QF-C4), combustible gas fan power supply switch (QF-C5). Complete power-up of the AC three-phase circuit and AC single-phase auxiliary power circuit.



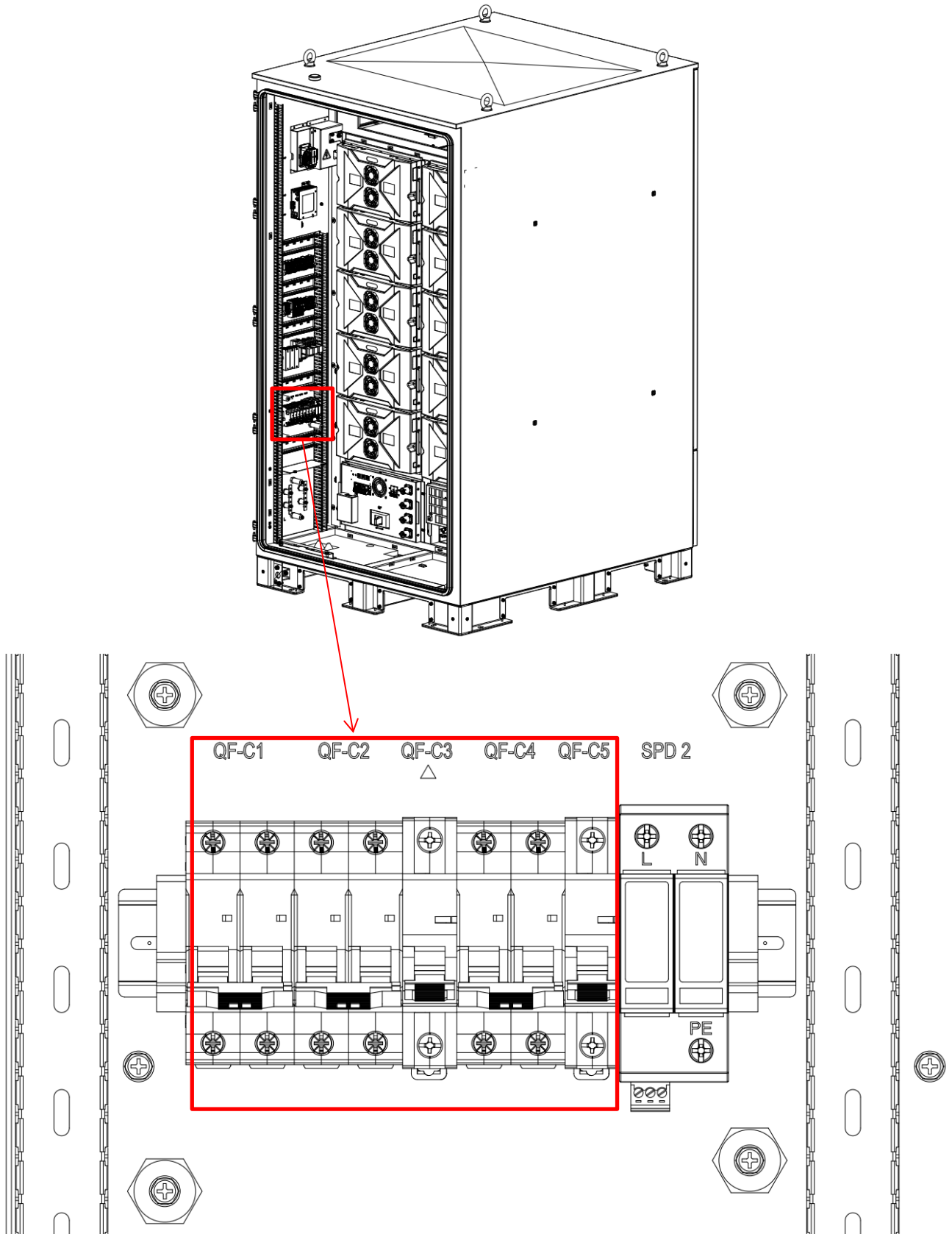

Figure 6.2.2.3 Schematic diagram of each switch

---

6、 After completing the above power-up steps, no user intervention is required. The system will automatically detect the communication status and verify the inverter's operational state. Once everything is ready, the battery system will complete its startup. Log in to the local LCU using your account credentials to access the user interface, where you can view the current system status and configure the operating mode.

### **6.2.3 Turn off the Power**

#### **(1) Shutdown steps**

Use the touchscreen to stop the inverter power and issue a shutdown command to the output equipment.

Hint:

This shutdown mode only turns off the operation of power devices in the system. The machine is in standby mode, and the output terminals remain powered.

#### **(2) Power-off step**

After confirming the cabinet shutdown, first de-energize the AC circuits, then de-energize the DC circuits. The following de-energization sequence is recommended:

Step1: Power off the AC grid: Disconnect grid protection switch (QF-A1) and Grid-Side Surge Protector Switch (QF-A2).

Step2: Auxiliary Power Shutdown: Disconnect the AC auxiliary power supply switch (QF-C1), auxiliary power surge protector switch (QF-C2), fan power supply switch (QF-C3), air conditioning power supply switch (QF-C4), and combustible gas fan power supply switch (QF-C5). Disconnect the auxiliary power circuit breakers QF1 and QF2 in the high-voltage control cabinet.

Step3: DC POWER supply shutdown: Press and hold the POWER button on the cabinet door for 3 seconds. The DC side control unit will shut down and the DC contactor will disconnect.

Step4: DC Circuit Disconnection: Disconnect the DC main circuit breaker QF in the high-voltage control cabinet.

### **6.2.4 Emergency Shutdown**

In case of an emergency, pressing the emergency stop button on the cabinet door will immediately cut off the primary circuit inside the cabinet and stop the charging and discharging path.

---

## VII. Maintenance Guidance

### 7.1 Maintenance Precautions

1) Before maintenance, it is necessary to use high-voltage testers or other instruments to test the metal parts that need to be touched or may be touched to avoid electric shock.

2) During maintenance, please pay attention to the warning labels inside the equipment to prevent personal injury caused by high-temperature, overweight and other components.

3) Maintenance must be carried out when the system is shut down and not energized, and the following steps should be followed:

Shut down the equipment.

② Disconnect all external power sources.

③ Confirm that the pre-stage switch has been disconnected and the grounding knife switch is properly connected.

After maintenance, all screws need to be tightened to the required torque.

4) The model of the new device replaced must be consistent with the original one. If you have any questions, please contact Sunwoda.

5) Daily inspections of the equipment can be carried out by personnel who have received relevant training, and the inspection and replacement of its components should be operated by authorized professionals.

6) The components behind the protective cover plate that can only be opened with tools are not accessible to users. Only qualified maintenance personnel are allowed to open such protective cover plates.

### 7.2 Maintenance Content

Due to the influence of factors such as humidity, temperature, dust and vibration in the operating environment, the internal components of energy storage systems that have been in use for a long time may experience varying degrees of aging or performance degradation. After the equipment is put into use, please be sure to inspect it regularly. The inspection items are as follows:

Inspect the Component	Inspection Content	Inspection Cycle
LCU Touch screen	① Check whether there are any fault alarm messages in the interface that have not been processed	Once a week
	② Check whether there are any changes in the parameter Settings of the interface	Once a month
	③ Check the operation data of the system and export and save it to relevant files (including operation logs)	Once a month
	④ Check whether the start-stop control function of the interface is operating normally	Once six month
	⑤ Check whether the resolution status of the interface has decreased or shown any abnormalities	Once a year
Cabinet Note: For any operation that requires touching the cabinet, please make sure to power off the cabinet and wait for 15 minutes before proceeding	① Check whether the operating noise of the cabinet is too loud or there are any abnormal sounds	Once three month
	② Check whether the outer wall of the cabinet has abnormal temperature	Once three month
	③ Check the surrounding environment of the cabinet for any accumulated water, dirt, heat sources or other items, and remove them in time	Once a month
	④ Check whether there is any dust accumulation at the air inlet and outlet of the cabinet. Is there too much dust or object covering the top of the cabinet	Once six month
	⑤ Check whether the cabinet shell shows signs of rust, oxidation, damage, paint peeling, etc	Once a year
Wiring harnesses and terminal blocks Note: Please be sure to power off the system and wait for 15 minutes before conducting any relevant inspection operations	① Check whether the power, communication and ground wire connections are loose	Once a year
	② Check whether the insulating skin of the power, communication and ground wires is damaged	Once a year
	③ Check whether the insulating winding tape of the power line is damaged	Once a year
	④ Check whether the terminal blocks or copper bars are loose or have rust or oxidation	Once a year
Air conditioner and cooling fan	① Check if there is any dust accumulation at the air conditioning vents and clean it in time (replace the dust-proof cotton if necessary).	Once a year
	② Check if there is any dust accumulation on the cooling fan and clean it in time	Once a year
	③ Check whether the fan is operating with abnormal sounds	Once six month
	④ Check if there is any abnormal sound when the air conditioner is running	Once six month
Fire protection devices such as smoke	① Regularly check the sensitivity of the smoke sensor by using controllable smoke	Once a year

---

sensors, temperature sensors, fire water connectors, etc.	② Regularly check the response sensitivity of the smoke sensor using a controllable heat source	Once a year
	③ Regularly open the upper cover of the fire water connection and check if it is rusty	Once a year

## VIII. Fault Handling

NO.	Report Unit	Fault Description	Possible Reason	Solution
1	EMS	The PCS communication is disconnected	The communication line connection is abnormal, or the LCU communication parameters are configured incorrectly	Check the communication line between the LCU and the PCS
2	EMS	The BMS communication is disconnected	The communication line connection is abnormal, or the LCU communication parameters are configured incorrectly	Check the communication line between the LCU and the BMS
3	EMS	The communication of the electricity meter is disconnected	The communication line connection is abnormal, or the LCU communication parameters are configured incorrectly	Check the communication line between the LCU and the electricity meter
4	EMS	Hardware shutdown trigger	The emergency stop switch is disconnected	Reset the emergency stop switch
5	EMS	The AC circuit breaker is disconnected	The AC circuit breaker is not closed or the AC circuit breaker is tripped	Check whether the wiring on the AC power grid side is abnormal and close the circuit breaker
6	EMS	The maintenance switch is pulled out.	The maintenance switch is not installed	Power down the system and install a service switch
7	EMS	The cabinet door is open	The cabinet door is not closed properly	Check the condition of the cabinet door
8	EMS	The smoke/temperature sensor is alarming	The connection of the sensor feedback line is abnormal, or the sensor is faulty	Check the wiring of the sensor or contact the manufacturer for handling
9	EMS	Fire trigger	The connection of the feedback wire of the fire extinguisher is abnormal	Check the wiring of the fire extinguisher or contact the manufacturer for handling
10	EMS	The cabinet is flooded	The wiring of the water immersion sensor is abnormal, or the water immersion sensor is faulty	Check the wiring of the water immersion sensor or contact the manufacturer for handling
11	EMS	The lightning arrester is alarming	The lightning arrester is damaged, or the connection of the	Check the status of the lightning arrester

			lightning arrester feedback line is abnormal	
12	PCS	The power grid has not been connected	The external power grid switch is not closed	Close the external power grid switch
13	PCS	Grid overvoltage	The input voltage on the AC side is too high	Check whether the grid voltage is normal
14	PCS	Grid undervoltage	The input voltage on the AC side is too low	Check whether the grid voltage is normal
15	PCS	Grid overfrequency	The input frequency on the AC side is too high	Check whether the grid frequency is normal
16	PCS	Grid underfrequency	The input frequency on the AC side is too low	Check whether the grid frequency is normal
17	PCS	The phase sequence of the power grid is incorrect	The phase sequence of the input voltage on the AC side is reversed	Adjust the phase sequence of the input voltage on the AC side
18	PCS	Phase loss in the power grid	The single-phase input voltage on the AC side is too low	Check whether the grid voltage is normal
19	PCS	The power grid voltage is unbalanced	The voltage difference between the alternating input phases on the AC side is too high	Check whether the grid voltage is normal
20	PCS	Grid island state	The input voltage on the AC side fluctuates	Check whether the power grid is disconnected
21	PCS	Power failure	The power supply of the power board is abnormal	Please contact the manufacturer
22	PCS	Busbar overvoltage	The grid voltage is too high	Check whether the grid voltage is normal
23	PCS	The DC power supply is not ready	The input voltage on the DC side is low	Check whether the DC wiring and switches are normal
24	PCS	Abnormal detection of battery voltage polarity reverse connection	The voltages of the positive and negative poles on the DC side are reversed	Check whether the positive and negative terminals on the DC side are connected correctly
25	PCS	Module overheating	The cabinet fan is not closed or overload operation/PCS fan failure	Close the switch of the cabinet cooling fan or please contact the manufacturer
26	PCS	Over-temperature load reduction	The cabinet fan is not closed or overload operation/PCS fan failure	Close the switch of the cabinet cooling fan and contact the manufacturer
27	BMS	There is severe overcurrent during	Abnormal current sampling	Please contact the manufacturer

		charging		
28	BMS	There is severe overcurrent during discharging	Abnormal current sampling	Please contact the manufacturer
29	BMS	The battery is severely overvoltage	Abnormal voltage sampling	Please contact the manufacturer
30	BMS	The battery is severely undervoltage	Abnormal voltage sampling or the battery has not been charged for a long time	Please contact the manufacturer
31	BMS	The battery is severely overheated	The power switch for the fan or air conditioner is not closed	Close the power switch of the fan and the power switch of the air conditioner
32	BMS	Severe low temperature of the battery	The power switch for the fan or air conditioner is not closed	Close the power switch of the fan and the power switch of the air conditioner
33	BMS	Abnormal high-voltage sampling	The DC circuit breaker of the high-voltage box is not closed	Close the DC circuit breaker of the high-voltage box
34	BMS	The temperature of the main control box is abnormal	The power supply switch for the high-voltage box fan is not closed, or the power supply switch for the cabinet fan is not closed	Close the power supply switch of the fan
35	BMS	Abnormal air conditioning communication	The power switch for the air conditioner is not closed	Close the power supply switch of the air conditioner





Sunwoda Energy Technology Co., Ltd

Sunwoda Industrial Park, No.18 Tangjia South Road, Guangming New District, Shenzhen, China

[www.sunwodaenergy.com](http://www.sunwodaenergy.com)