





CSS – OD / 102 kWh
Grid Tied Commercial
Energy Storage Solution
Quick Installation Guide

Version 1.6

Legend

 **WARNING!** This symbol denotes a hazard. It calls attention to a procedure that if not correctly performed or adhered to could result in injury or loss of life. Do not proceed beyond a warning note until the indicated conditions are fully understood and met.

 **CAUTION!** Denotes a hazard. It calls attention to a procedure that, if not correctly performed or adhered to, could result in damage or destruction of the product. Do not proceed beyond a caution sign until the indicated conditions are fully understood and met.

 This symbol indicates that this is the Protective Earth (PE) terminal that must be firmly grounded to ensure the safety of operators.

Safety Instructions

 **WARNING: RISK OF ELECTRIC SHOCK**
DO NOT touch the wires, contacts, terminals, or any conductors connected to the grid circuit inside the equipment.
Failure to follow safety instructions could result in severe injury or death from electric shock.

 **WARNING: LETHAL HIGH VOLTAGES exist inside the product.**

- Note and abide by all warning signs on the product.
- Observe the safety precautions listed in this manual and other related documents.

 **WARNING: Damaged Equipment Hazards**

- Damaged equipment or system failure may cause electric shock or fire!
- Perform an initial visual inspection of the equipment for damage or other hazards before operation.
- Check whether other external devices or circuit connections are secure.
- Confirm that this equipment is in a safe state before operating it.

 **WARNING:** This equipment must be installed by **licensed electrician** and qualified personnel only. The installation and wiring of this equipment must comply with all applicable national, state/provincial, local electrical codes and standards. Attempting installation by unqualified individuals could result in unsafe operation, code violations, personal injury/loss of life, or damage to the equipment.

 **WARNING: Battery Protection**
DC HIGH VOLTAGE! ELECTRIC SHOCK HAZARD!
The battery in the system generates a high voltage when connected. Accidental contact can result in electric shock or life-threatening injuries.

 **WARNING: Ground Fault Protection**

- When a ground fault occurs in the integrated PCS, there may be fatal high voltage in parts that are not originally charged. **DANGEROUS IF ACCIDENTALLY TOUCHED!**
- Before operation, ensure there is no ground fault in the system, and take relevant protective measures.

 **WARNING: Live Line Measurement**

- There are high voltages in the equipment in the integrated PCS, and accidental touch may cause fatal electric shock hazards.
- During live measurement, take appropriate protection, such as wearing insulating gloves.
- There must be an accompanying person to ensure personal safety.

 **WARNING: Improper parameter settings**

- Improper parameter settings may affect the normal function realization of internal devices.
- Only authorized professionals can set the parameters.

 **WARNING: Regulatory Compliance**
The installation and various operations of the integrated PCS must comply with the relevant standards and regulations of the country/region where the project is located

Personal Protective Equipment



Safety Rubber Shoes



Helmet



Rubber Gloves



Safety Clothing



Goggles

Required tools for Battery Cabinet 102.4 kWh & Battery Inverter 50 kW

 **WARNING!** Use only insulated tools



Torque wrench with 7mm, 10mm, 17mm, 18mm, 19mm sockets



Wire Cutter



Crimping tool



Phillips screwdriver $\varnothing 6$ mm, L= 230 mm



Heat gun



Multimeter (≥ 1000 V_{DC})



Cable Stripper



Wire Stripper



Drill ($\varnothing 10$ mm drill)



Box Cutter



Pipe Cutter



Ladder



Rubber Hammer



Slotted Screwdriver (10 mm slot)



Slotted Screwdriver for Terminal Block Screws (2 mm slot)



Adjustable Wrench



Open-end torque wrench

General Description of Battery Cabinet & Battery Inverter

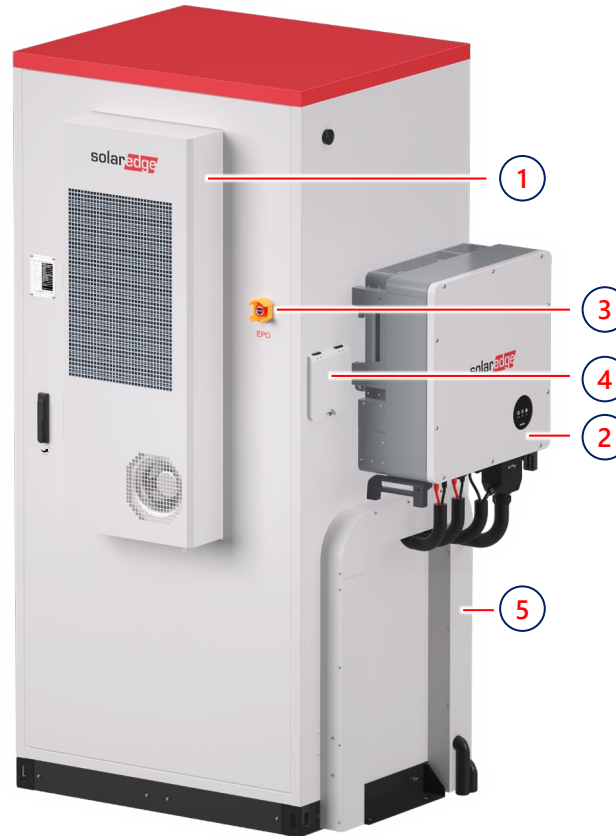
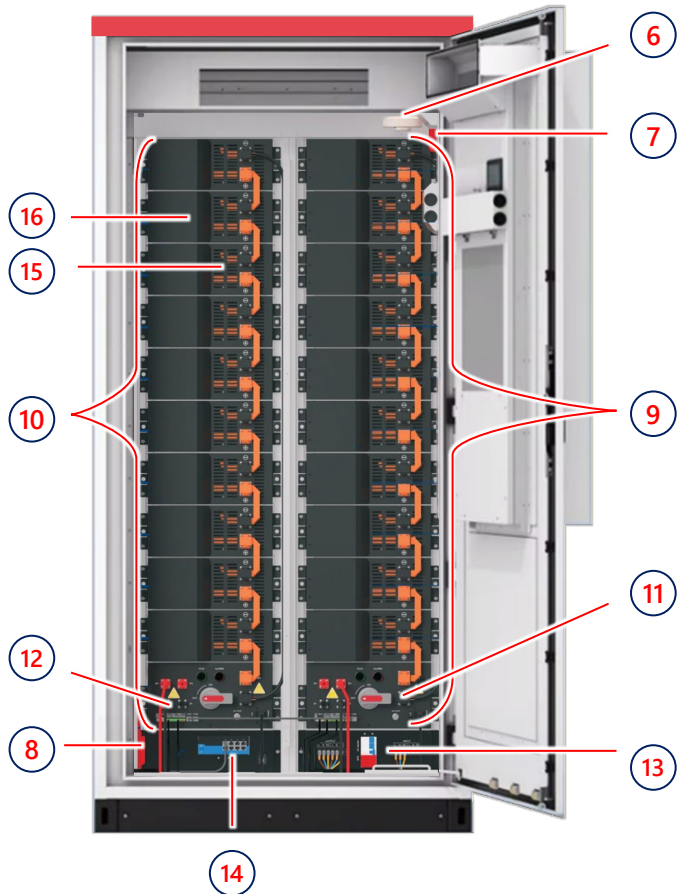

1. Battery Cabinet HVAC
2. Battery Inverter 50 kW
3. Emergency Power Off (EPO) switch
4. CSS Local Interface
5. Wiring Duct
6. Photoelectric Smoke Detector
7. Aerosol Fire Extinguisher 1
8. Aerosol Fire Extinguisher 2
9. Cluster 1 (10 EMs + CMU1)
10. Cluster 2 (10 EMs + CMU2)
11. Cluster Management Unit 1
12. Cluster Management Unit 2
13. AC Interface Box
14. Battery Cabinet Management Unit
15. Energy Module (x20)
16. Energy Module Management Unit

**Battery Cabinet
102.4 kWh**



1421 KG

**Battery Inverter
50 kW**

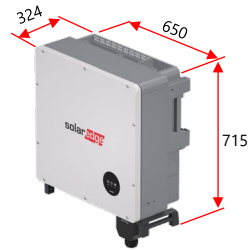

68 KG

**Battery Inverter 50 kW
Battery Cabinet 102.4 kWh**
*Assembled Dimensions



1489 KG

All dimensions are in [mm]

Default Layout & Clearance Distances (Top & front View)

All dimensions w/o units are in [mm]

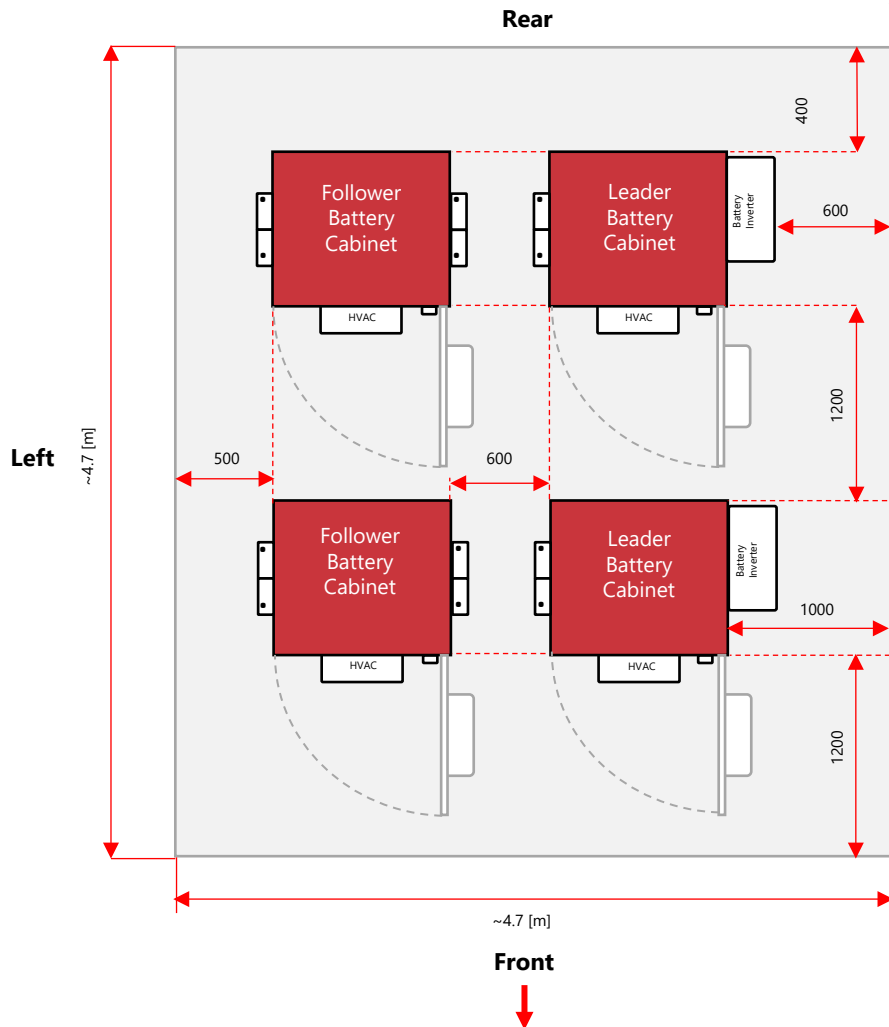

Battery Cabinet + Battery Inverter	
Direction	Distance [mm]
Front	1200
Rear	400
Right	1000
Left	600

Right

⚠ WARNING! To avoid flood damage and safety hazards, the cabinet must be installed on a concrete platform with a minimum height of 300 mm.



Above ground: Minimum 300

Below ground: Minimum 400



NOTE!

- Local codes and regulations could extend the required clearances beyond what is specified in this manual
- Before proceeding with installation, consult with relevant authorities to ensure compliance with local regulations concerning clearance distances.

CAUTION

1. The installation, use, and operation of outdoor equipment and cables, including but not limited to the movement of equipment, operation of devices and cables, connection or disconnection of signal interfaces exposed to outdoor conditions, and work at heights. Outdoor installations are strictly prohibited during severe weather conditions such as lightning, rain, snow, or high winds.
2. Avoid installing the equipment near underground facilities like underwater pipes and air outlets or in places prone to condensation. Additionally, steer clear of areas susceptible to water leakage, such as around air-conditioning outlets, vents, and outlet windows in the machine room. This will help prevent liquids from entering the equipment and causing malfunctions or short circuits.
3. Avoid installing the equipment in areas with poor geological conditions, such as rubbery or weak soil, waterlogged ground, or regions susceptible to land subsidence. When installing in a sandy environment, increase the frequency of routine maintenance for the battery vent and HVAC systems: perform a visual inspection weekly and clean as needed based on observed conditions.
4. Do not place the equipment or operate it in a flammable environment or an environment that contains explosive gas or smoke.
5. Avoid installing the battery cabinet in sandy environments.
6. Avoid installing the battery cabinet on unstable or vibrating foundations.
7. Do not install the battery cabinet in a working environment with metal conductive dust.
8. When the equipment is running, do not cover the vents or heat dissipation system to prevent fire due to high temperature.

CAUTION! For indoor installations ventilated room is required.

CAUTION! CSS – OD solution must be installed: >2km from the sea, when installed in an outdoor location, or >1km when installed in indoor locations.

NOTE Battery Cabinet & Battery Inverter max noise is <65 dBA @ 1 meter distance.

CAUTION! When Installed in indoor locations consider heat dissipation values of all installed devices when choosing appropriate room / space for their installation.

Battery Cabinet	
Max Power	Heat Dissipation
50 kW	0.87 kWh 2970 BTU
Battery Inverter	
Max Power	Heat Dissipation
50 kW	1.5 kWh 5118 BTU

IMPORTANT: It is recommended that all battery branches should uniformly include Leader or Leader & Follower cabinets.

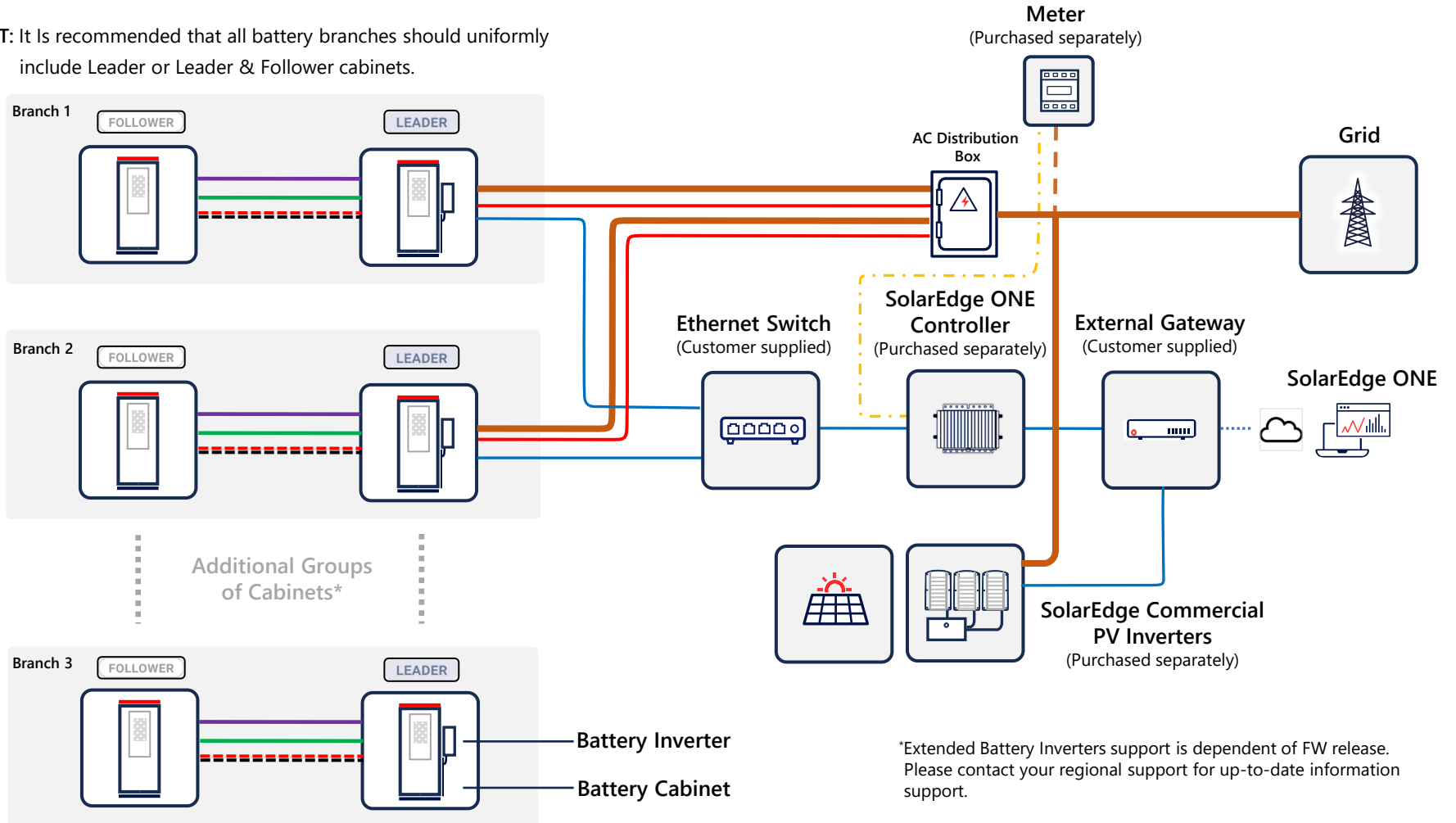

- Three Phase AC Cable, multi stranded class 5 or 6, 25-35 mm², 50 kW
- DC+ & DC- Power cables (x2)
- Single Phase Auxiliary AC Cable (not provided)
- CAN Comm. Cable (LAN)

- Modbus TCP Communication Cable (LAN)
- RS485 Comm. Cable (not provided)
- AC Aux. Cable

*Extended Battery Inverters support is dependent of FW release. Please contact your regional support for up-to-date information support.

NOTES:

- Keep in upright position 
- Before opening, validate package integrity



IMPORTANT: Do not open damaged packages & contact SolarEdge to review the case.

NOTE: For SolarEdge commercial Battery storage and transportation guidelines refer to: <https://knowledge-center.solaredge.com/sites/kc/files/se-commercial-battery-storage-transportation-and-storage-guideline-eng.pdf>

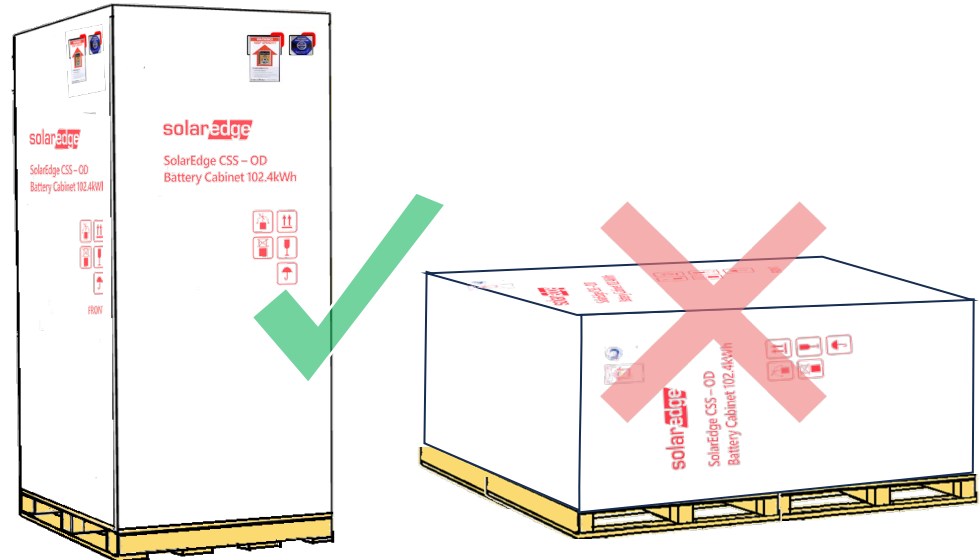

NOTES: For Battery Cabinet Package

- Verify that the shock and tilt label sensors, on the front and right sides of the package, show green indication.
- When opening package, check the integrity of the fire safety solution. If aerosol gas was ejected due to any fault occurred during transportation the battery cabinet shall be replaced.
- If one of the sensors is red, please contact SolarEdge and do not open the package.



Transporting Battery Cabinet with the Wooden Box

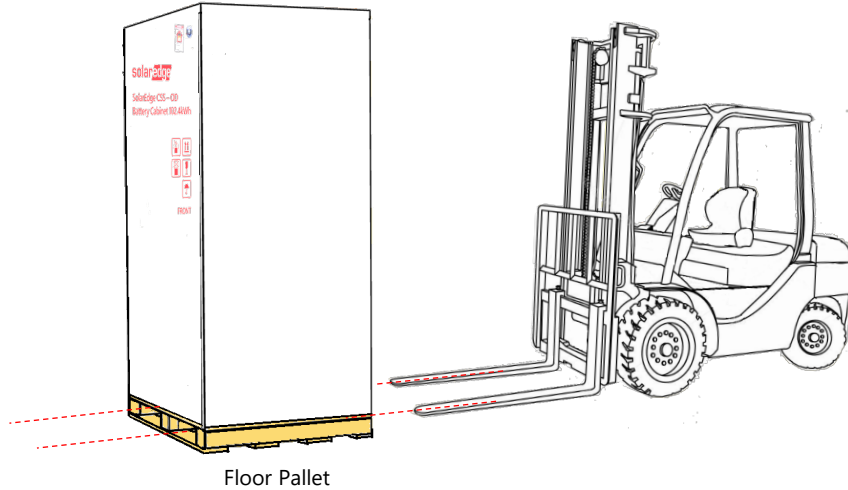

Transporting Battery Cabinet Standalone

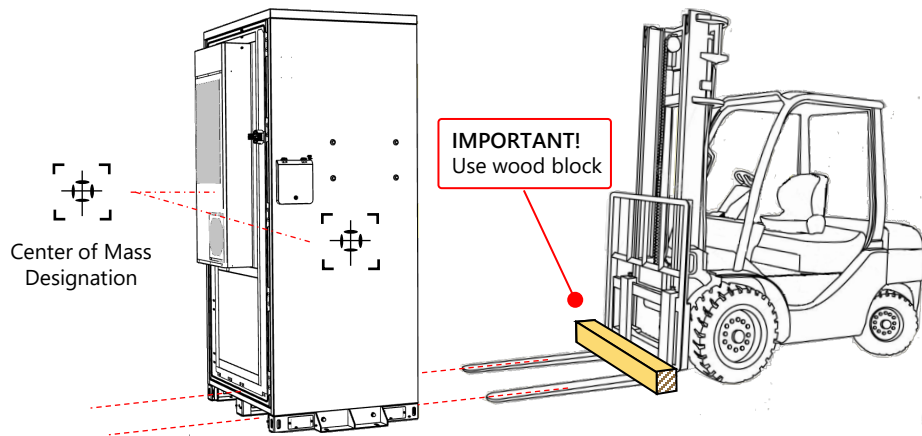

Forklift Requirements

WARNING! Forklift must be able to lift At least 5 tons carrying capacity

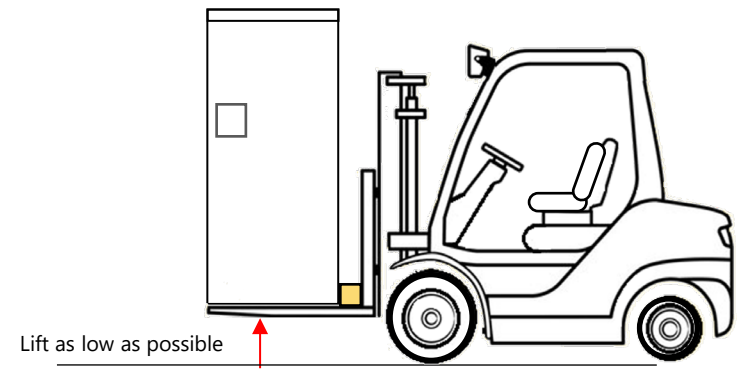
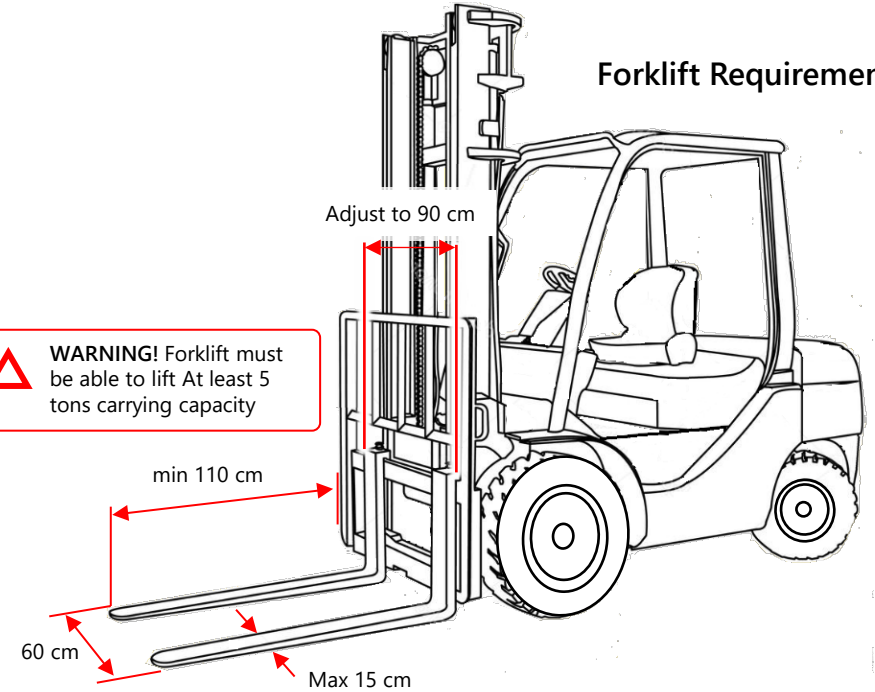

HOISTING REQUIREMENTS

WARNING!

1. A trained and qualified lifting personnel is required.
2. Do not operate a hoist if severe weather or wind is apparent when conducting hoisting outdoors.
3. Keep unauthorized people from entering the area and standing under crane boom.
4. Ensure that the crane and slings meet the load-bearing requirements.
5. To prevent the cabinet from scratching, do not drag it when installing and removing hoisting equipment.
6. Check to ensure that the hoisting tools are in good condition.
7. Ensure that all the doors of the equipment are closed and locked during transportation.

Standalone Battery Cabinet Crane Transportation

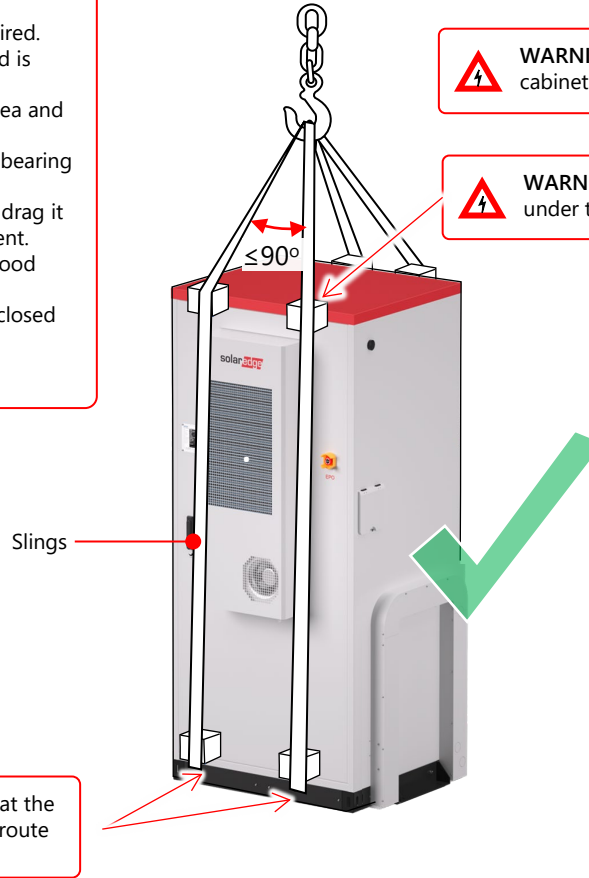

WARNING! Do not tilt the cabinets during transportation.

WARNING! Use edge protectors under the lifting straps.

WARNING! Use the slots at the bottom of the cabinet to route the lifting straps.

Packaged Battery Cabinet Crane Transportation

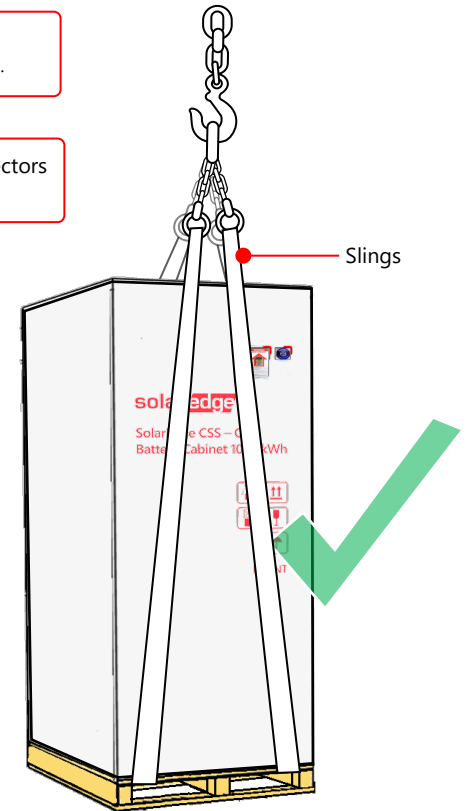



NOTE: Disassembly of wooden box must start from the top side

1 Top

5 Rear

NOTE: leave protective nylon covering this area

3 Left

NOTE: Use flat head screwdriver to unfold the connecting buckles

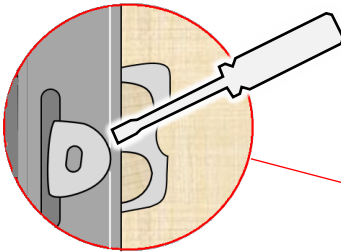

2 Front

solar_{edge}
SolarEdge CSS - OD
Battery Cabinet 102.4kWh

4 Right

7

Battery Cabinet
Accessories Box

8

NOTE: For the side brackets, remove only screws connecting to pallet. (x4)

NOTE: Scrap the front and rear brackets



Remove the nuts using 19 mm socket (x8)

Mounting Battery Cabinet on a Mounting Stand

1

NOTE: These expansion bolts & washers are **not supplied**. Torque is dependent on mounting surface. For concrete: 60Nm

X6 (3x front & 3x rear)

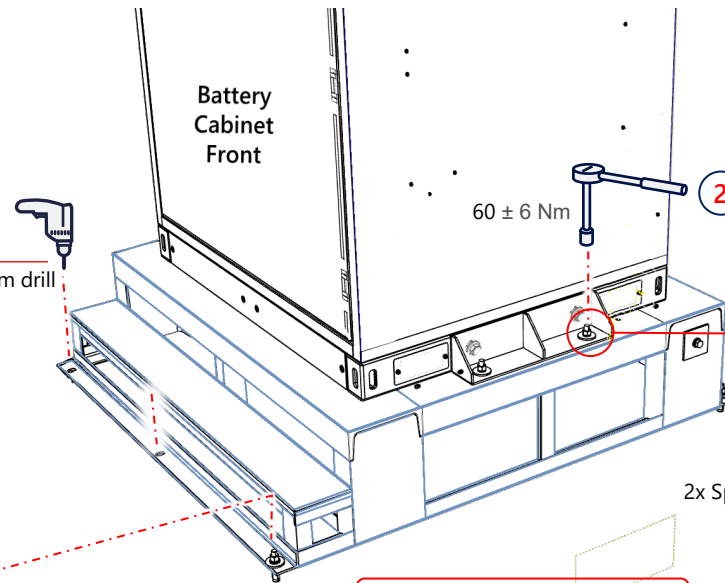
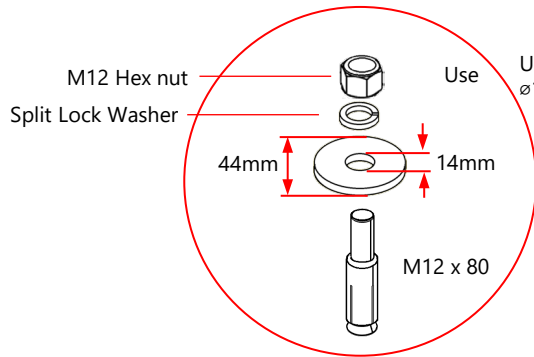

X4 (X2 on each side)

NOTE: Bolts and washers are **not supplied**

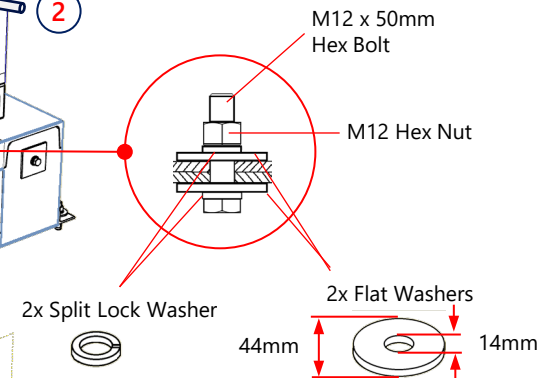

NOTE: For Mounting Stand production guidelines, see Appendix B.

IMPORTANT NOTE!

1. Open Mounting Stand provided by the customer.
2. General dimensions & requirements of the Mounting Stand are provided in Appendix B.
3. The customer's civil engineer shall review and approve the structure provided by the customer (open Mounting Stand).

Mounting Battery Cabinet on a Concrete Platform Base

Option 1: Unified Concrete Platform Base with Embedded Steel Plate with Studs

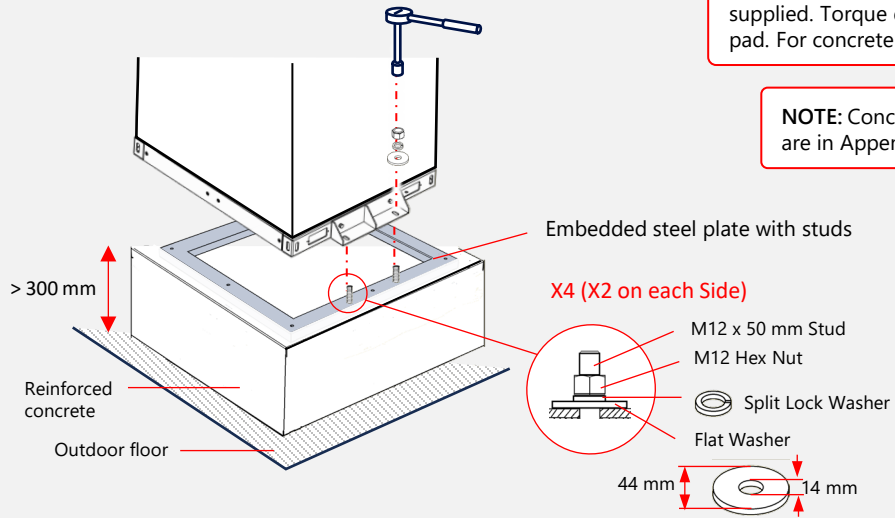

NOTE: Bolts, nuts, and washers are not supplied. Torque depends on the mounting pad. For concrete pads use 60 Nm.

NOTE: Concrete pad guidelines are in Appendix B

Option 3: Unified Concrete Platform Base with Drilling Occurs on Site

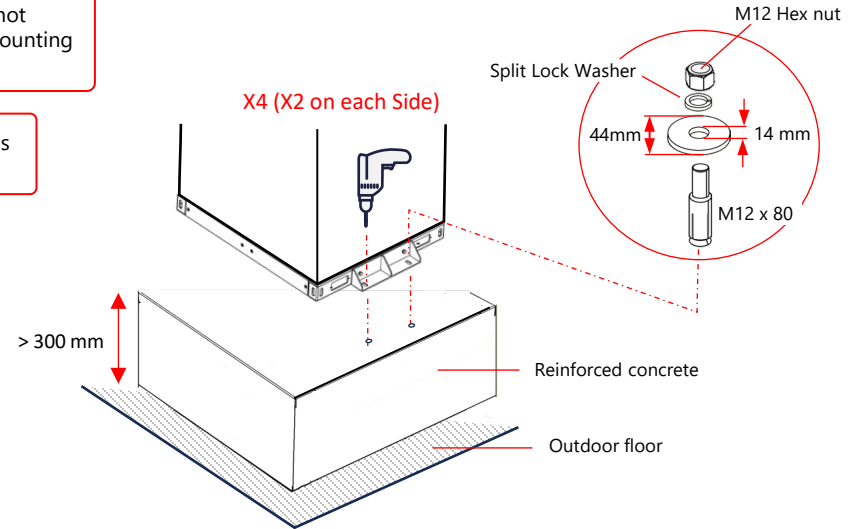

Option 2: Hollow Concrete Platform Base with Embedded Steel Plate with Studs

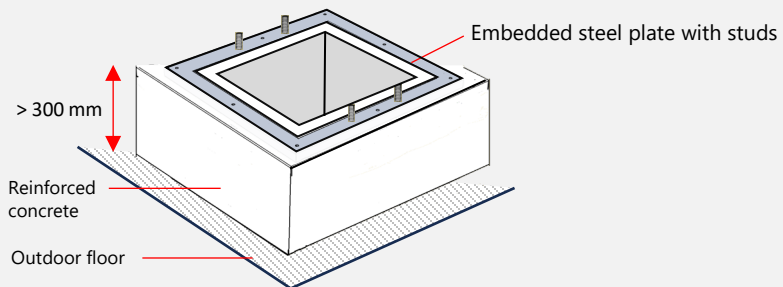

Option 4: Hollow Concrete Platform Base with Drilling Occurs on Site

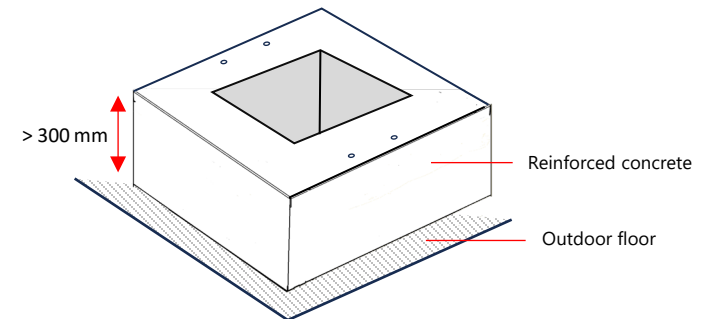

Battery Cabinet Package Contents (Inside Accessories Box)

Battery Cabinet (Cluster 1)
to Battery Inverter DC Cables (3m) (A)



BAT1

Battery Cabinet (Cluster 2)
to Battery Inverter DC Cables (3.5m) (B)



BAT2

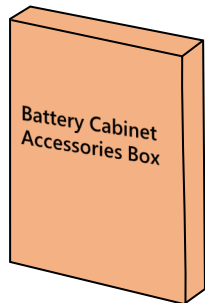

PAY ATTENTION!
All Cables are marked
with a designation label



Battery Cabinet to
Battery Inverter
CAN cables (3.5m) (C)



PCS-COM

PE cable (0.7m) (E)



NOTE: THIS PROVIDED CABLE
SHOULD NOT BE USED

Battery Cabinet to Battery
Inverter RS485 cable (3.5m) (D)



Battery Cabinet to BUI100
AC Auxiliary Cable (10m)

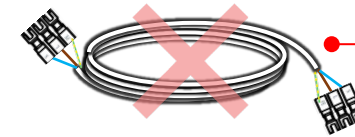

NOTE: THIS PROVIDED CABLE
SHOULD NOT BE USED

Battery Cabinet to BUI100
Modbus TCP Cable (10m)



Battery Cabinet
Wiring Duct (G)

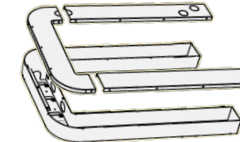

Forklift Slots Covers (x4) (Y)
(Outside Accessories Box)

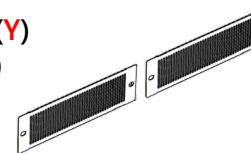

Battery Cabinet Package Contents (Inside Battery Cabinet)

Sealant (x2) (H)



Corrugated Plastic
Conduit \varnothing 34.5 mm (I)



Corrugated Plastic
Conduit \varnothing 21 mm (J)



Battery Inverter Package Contents

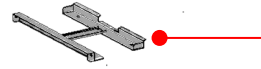

Battery Inverter Mounting Bracket (K)

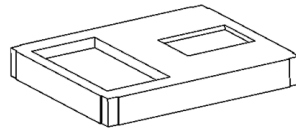

Battery Inverter

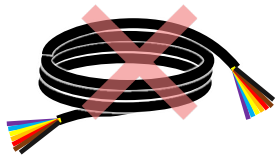
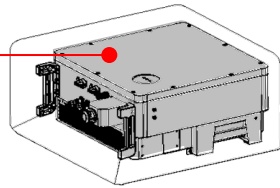

NOTE: THESE PROVIDED CABLES SHOULD NOT BE USED

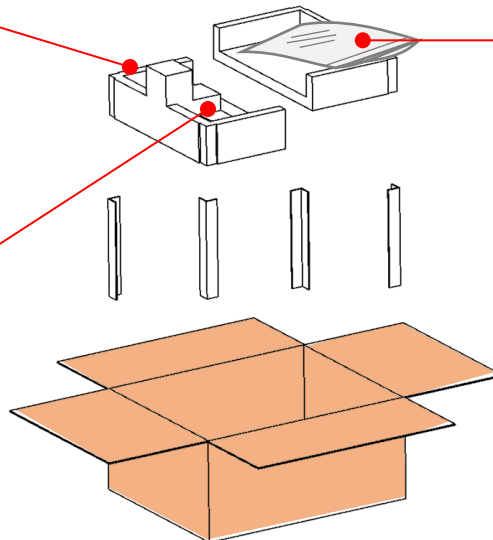

NOTE: THIS PROVIDED CABLE SHOULD NOT BE USED

DC-Bus Connector (N)

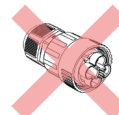

Bracket Mounting Screws (x4) (Q)

17mm x 30

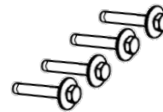

Communication Cable Connector (O)

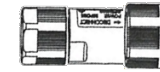

Bracket Lock Screws (x2) (R)

10mm x 16



M6 Lugs (x5) (S)



NOTE: These lugs are compatible with class 2 wires. Please ensure you provide your own lugs if class 5 or 6 wires are used on site.

NOTE: THIS PROVIDED TOOL SHOULD NOT BE USED

Right-angled Torx Star Allen key (P)

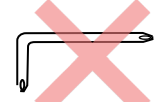

Cables Shrinks (x5) (T)

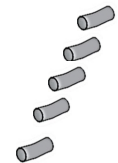

Cabling Extension Kit* Package Contents

DC+ Paralleling
Cables (x2) (5m) (U)

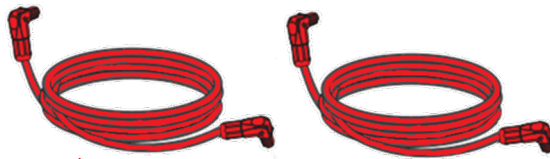

BAT1

BAT2

DC- Paralleling
Cables (x2) (5m) (V)



BAT1

BAT2

AC Auxiliary
Cable (x1) (5m) (W)



Modbus TCP
Cable (Ethernet) (x1) (5m) (X)



PAY ATTENTION!
All Cables are marked
with a designation label

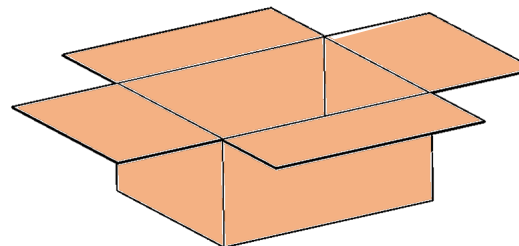

*This kit is ordered separately for 2:1 installations

Mounting the Battery Inverter onto the Battery Cabinet

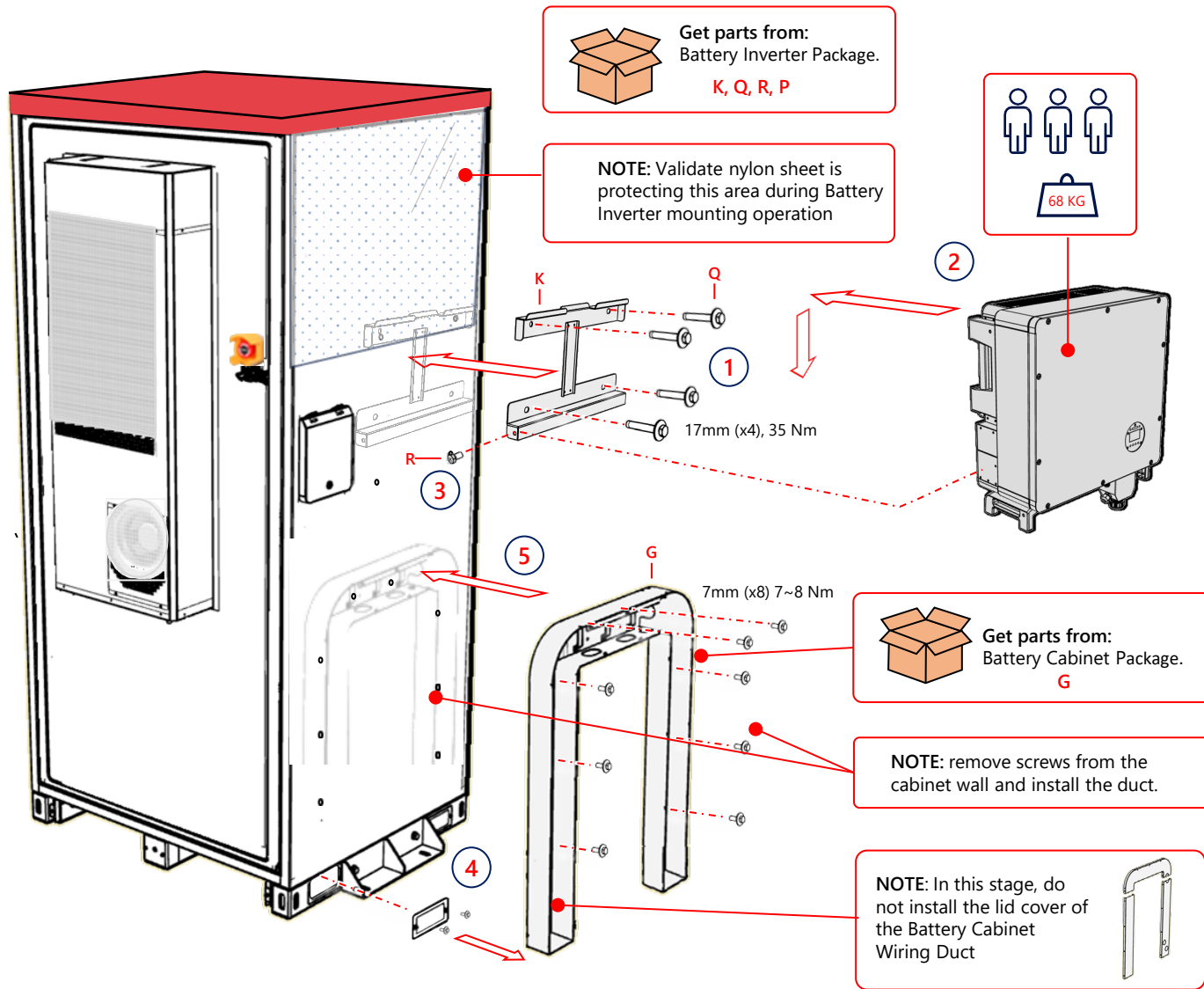

Battery Cabinet & Battery Inverter PE Wiring Management

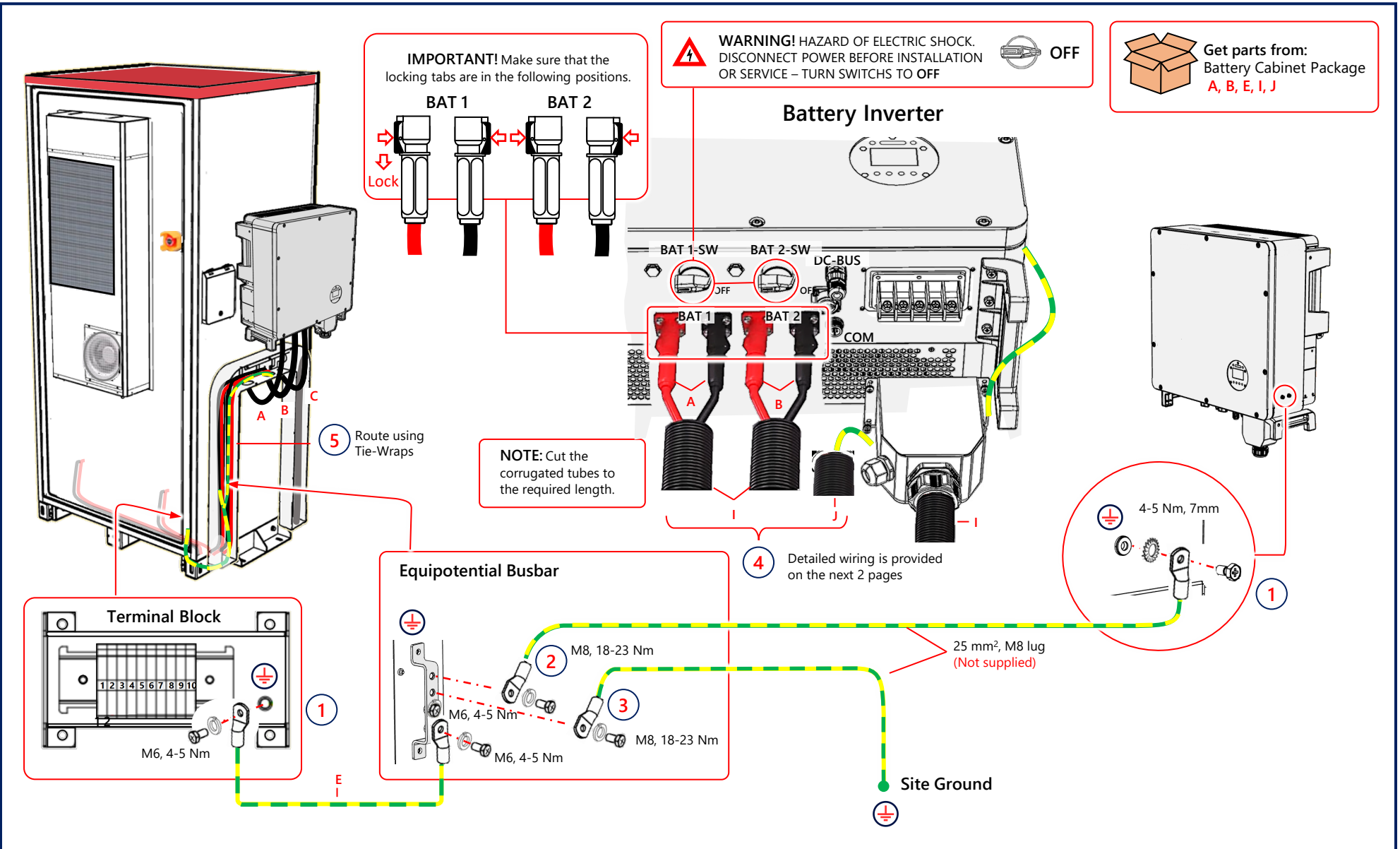

Wiring Single Battery Cabinet to Battery Inverter

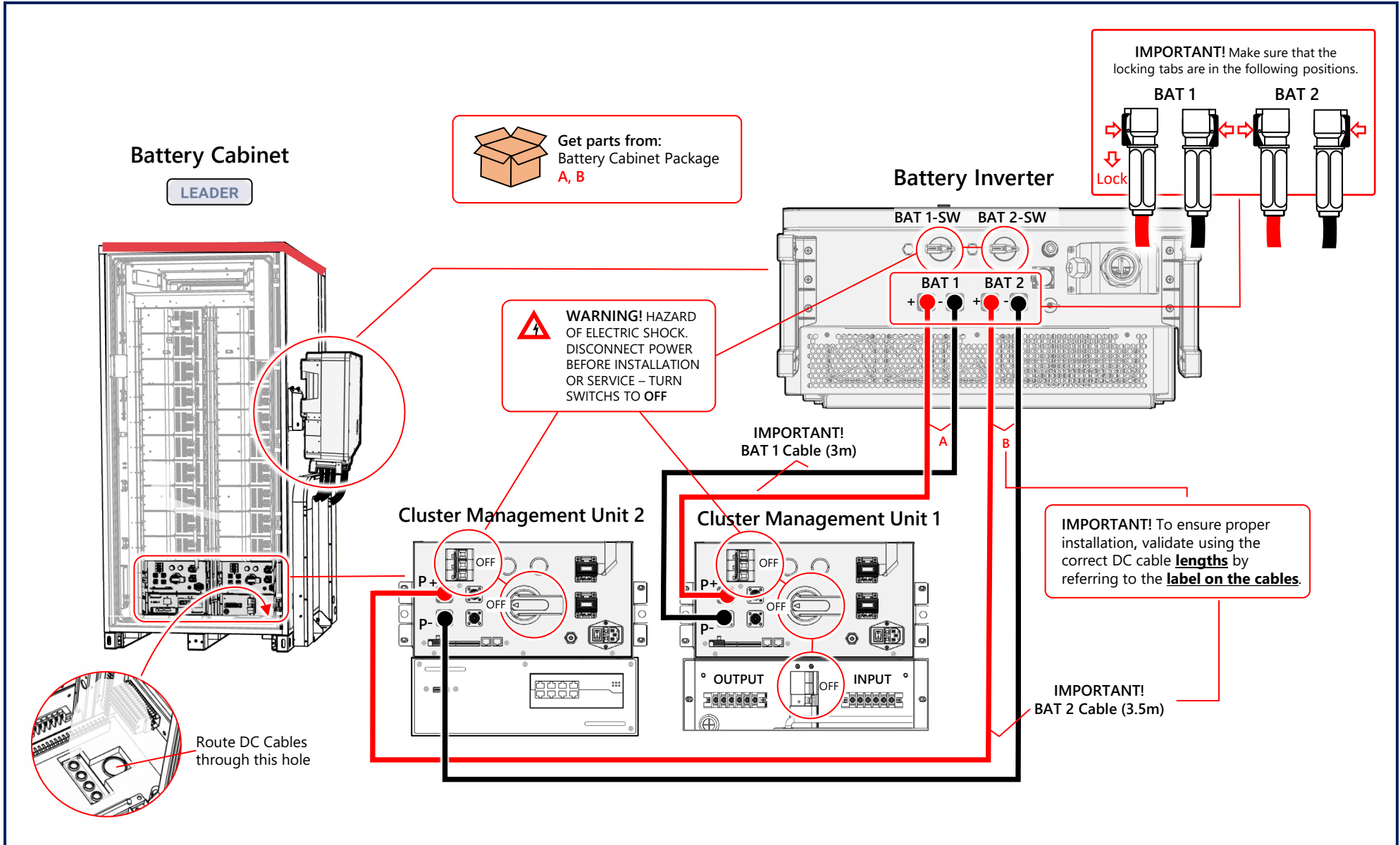

Wiring Battery Inverter to the Grid

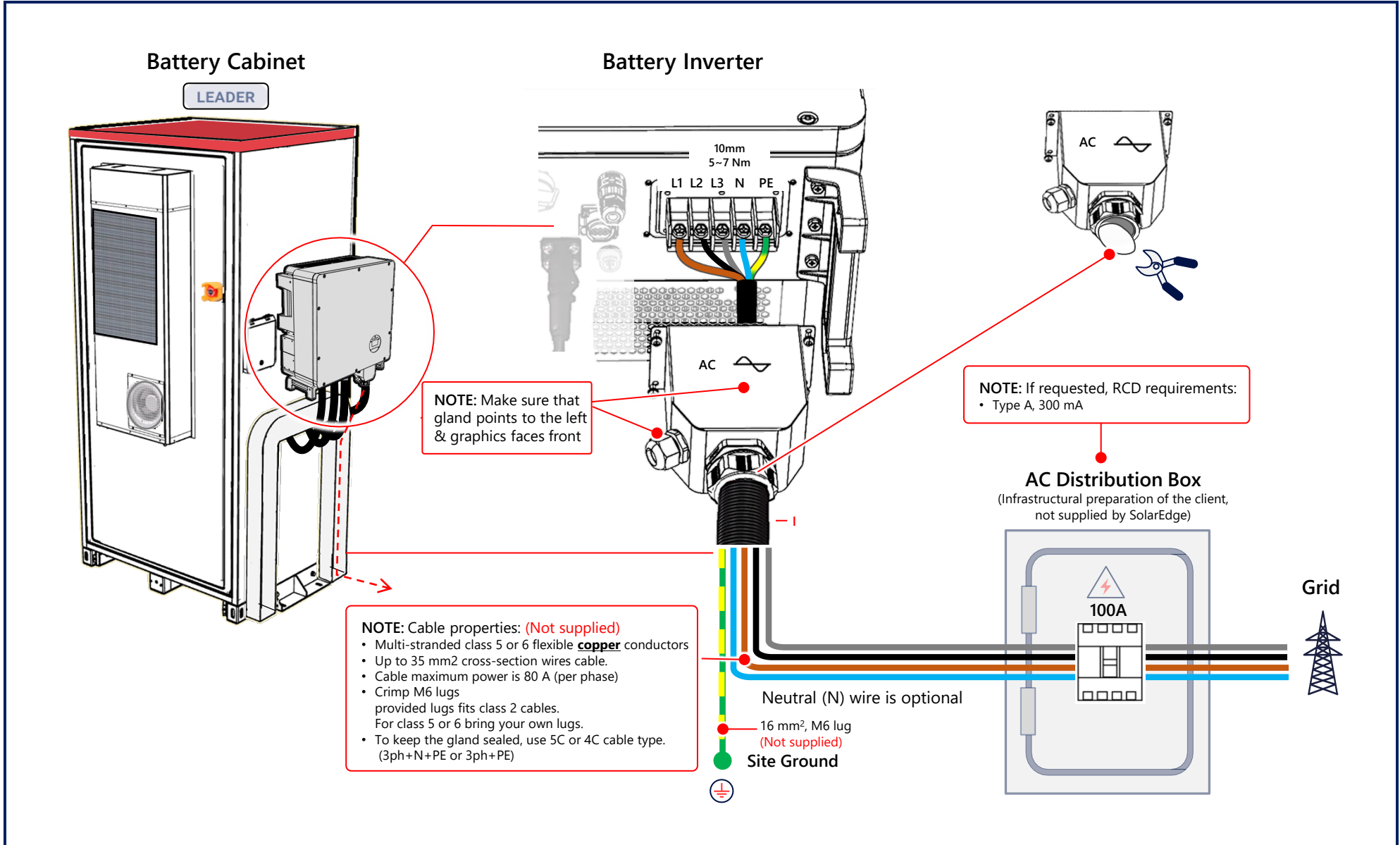

Battery Cabinet

LEADER

IMPORTANT!
The HVAC AC auxiliary wiring is connected solely to the Leader Battery Cabinet from the AC distribution box.

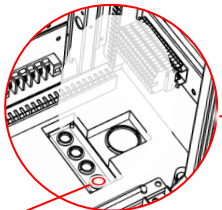
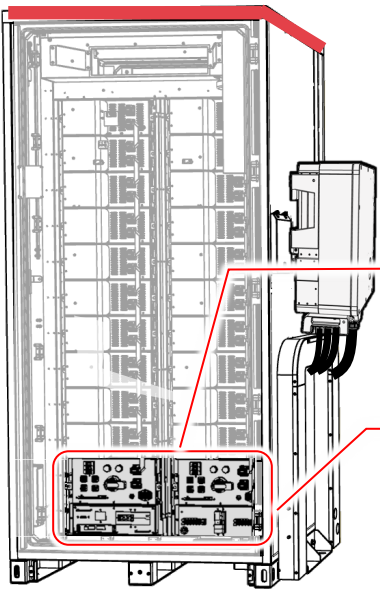

AC Auxiliary Cable

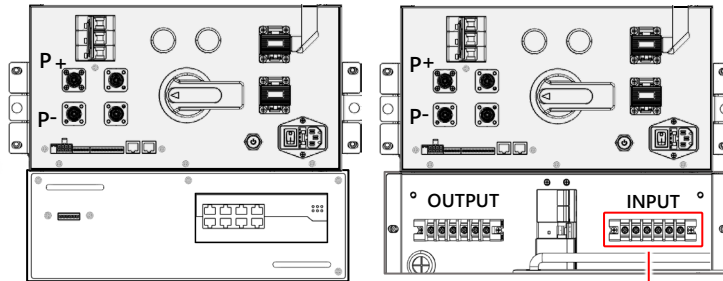

AUX Cable - Used for A/C power supply (Not supplied)

NOTE: If requested, RCD requirements:
• Type A, 30 mA

AC Distribution Box
(Infrastructural preparation of the client, not supplied by SolarEdge)

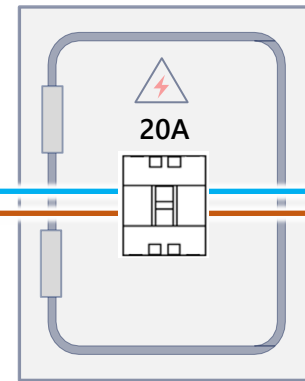

Wiring Communication between Battery Cabinet & Battery Inverter

Get parts from:
Battery Cabinet
Package C and D

Battery Cabinet

LEADER

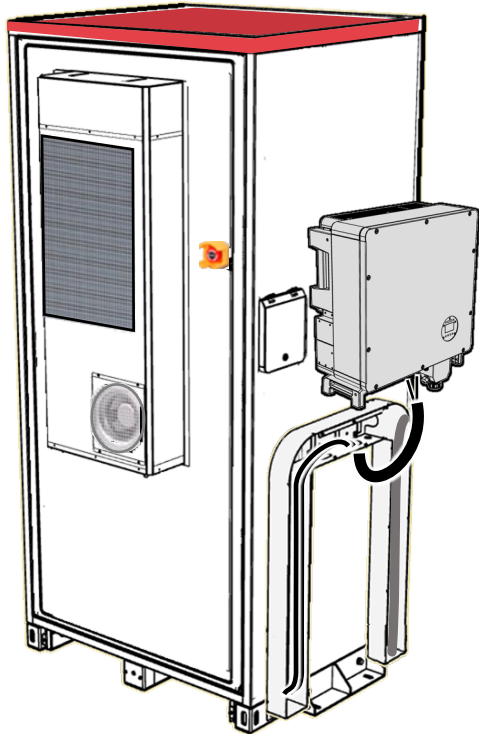

Battery Inverter

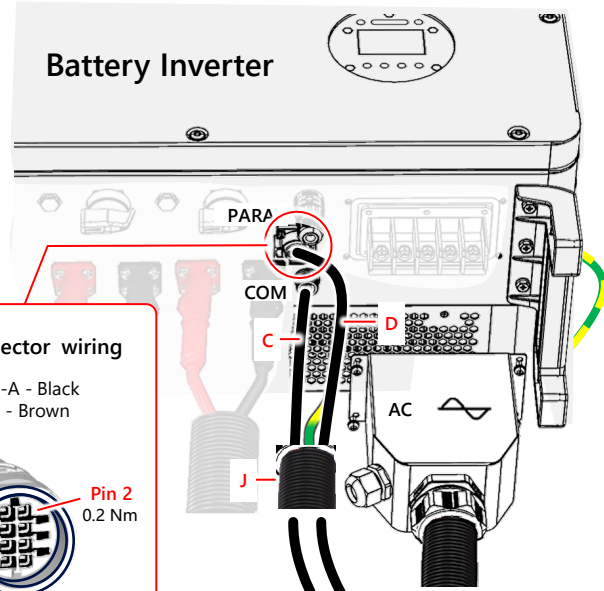

PARA connector wiring

Pin 1. RS485-A - Black
Pin 2. RS485 - Brown



Get part from:
Battery Inverter
Package O

Leader Battery Cabinet

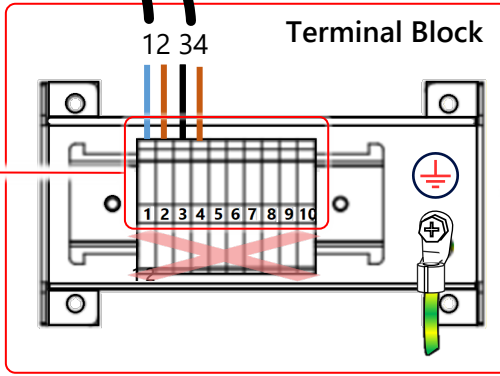
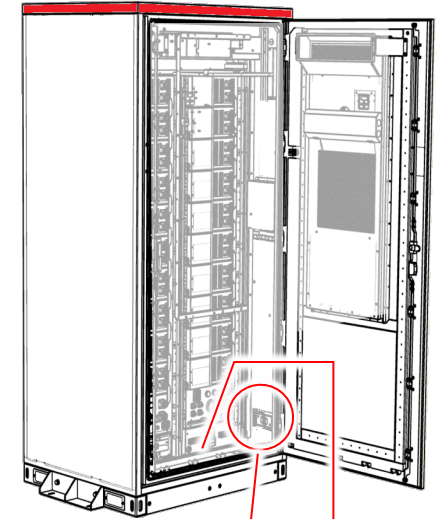

IMPORTANT! Connect wires only to top terminals

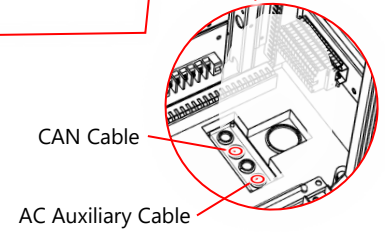

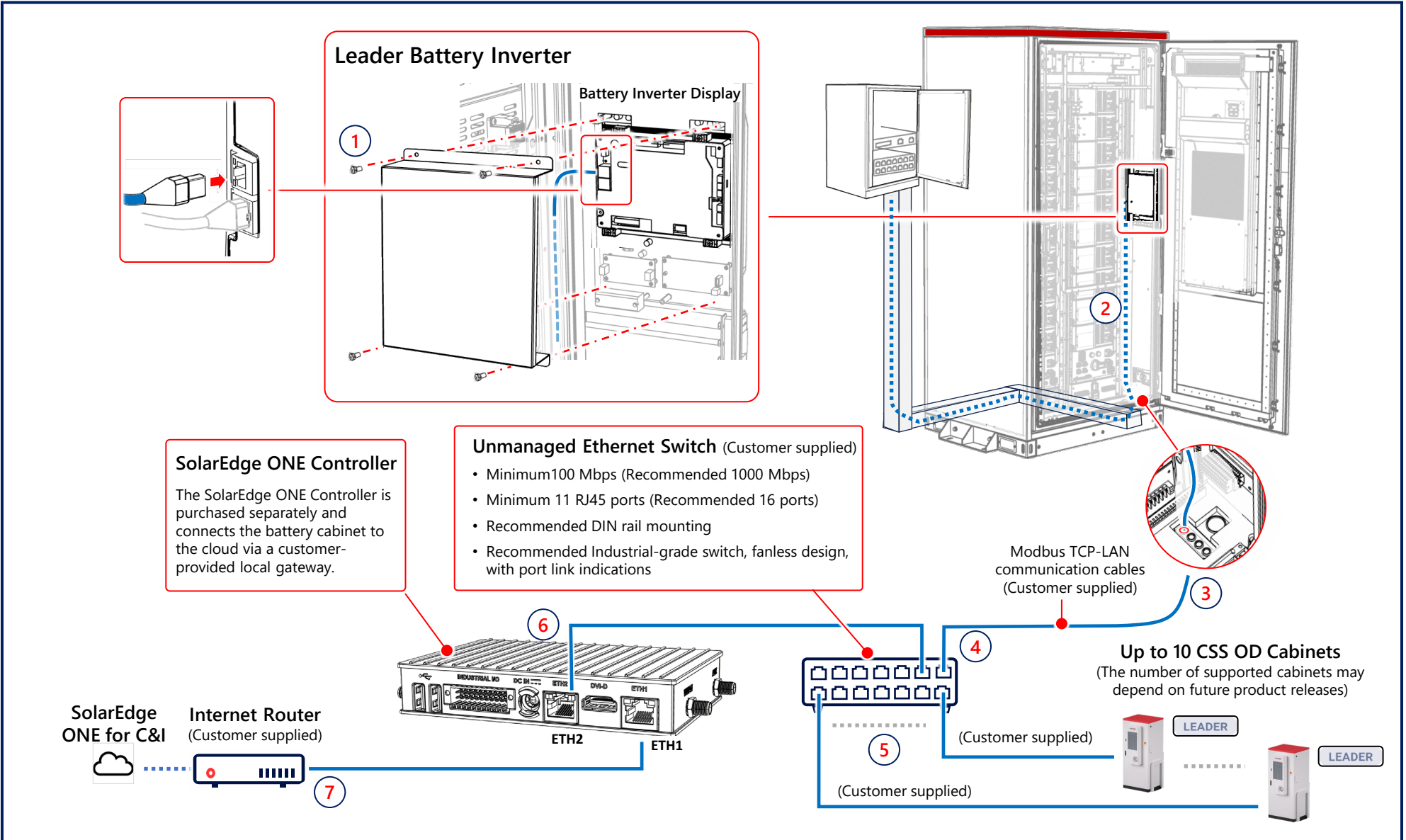

Sealing and Closing Wiring Duct Lid and Panels

IMPORTANT! Use fire clay to block the cable gaps and seal un-routed wiring holes.



Get parts from: Battery Cabinet Package
(H, G [Duct Cover])

Sealant(x2) (H)

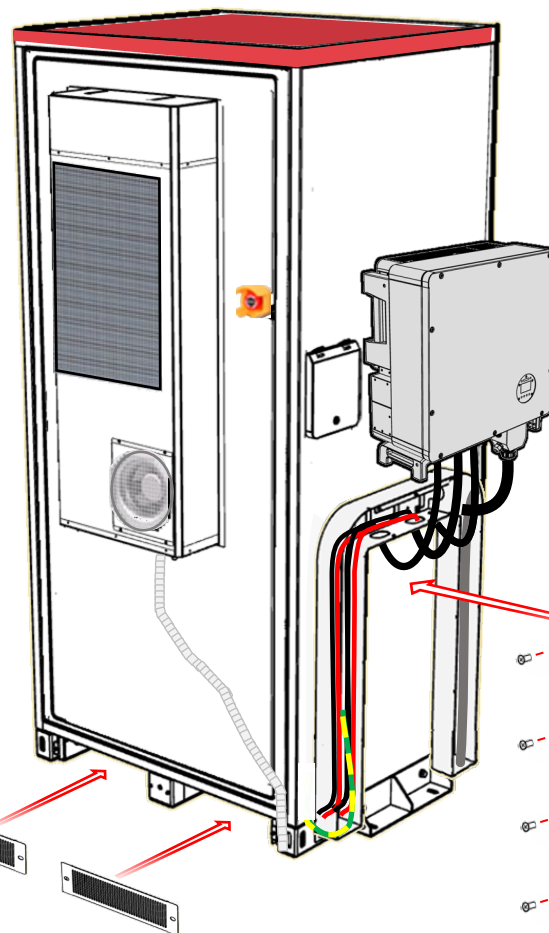
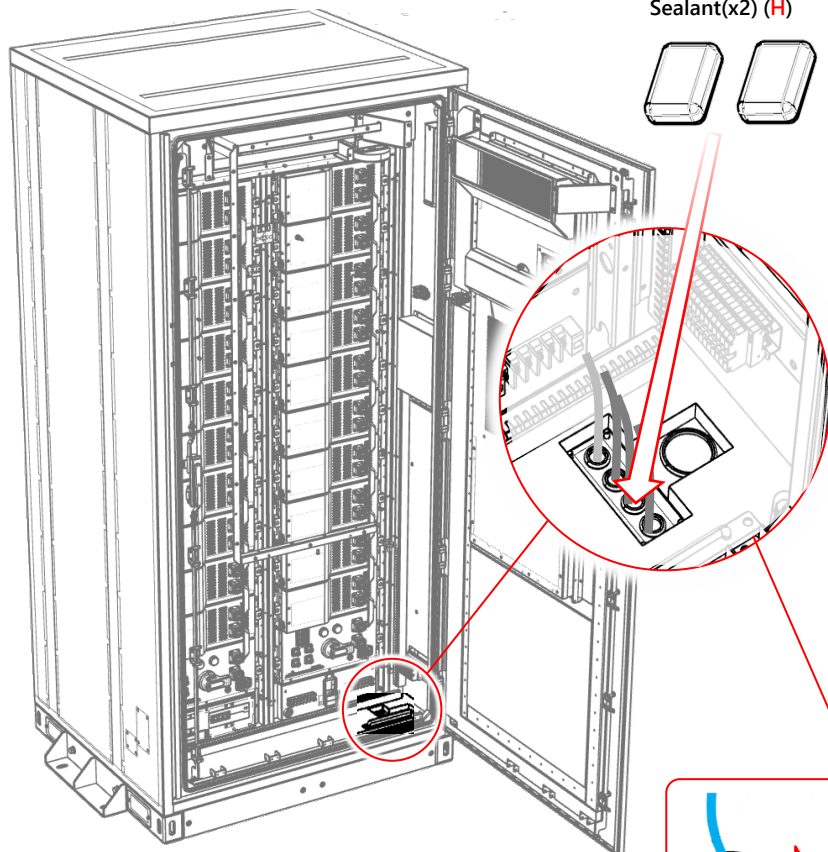

7mm X 10
1.8~2.4 Nm

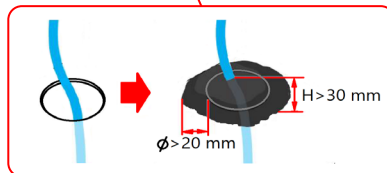

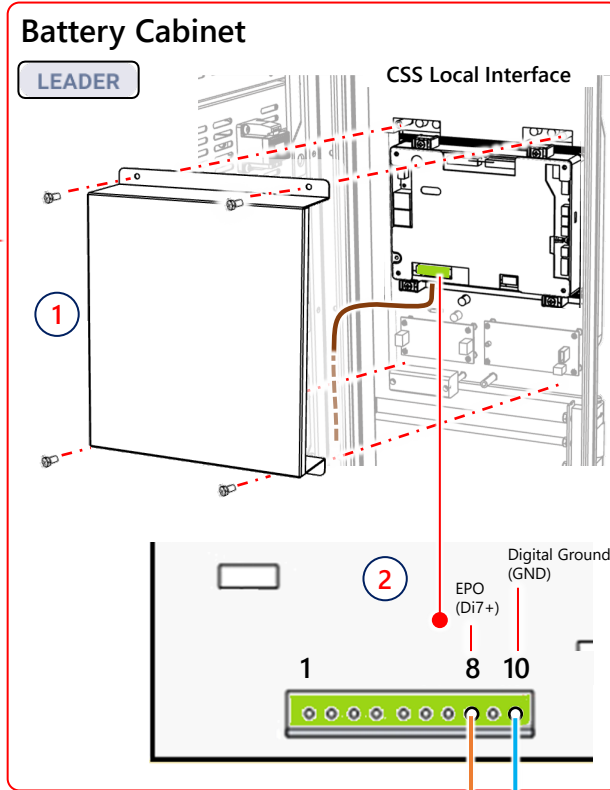
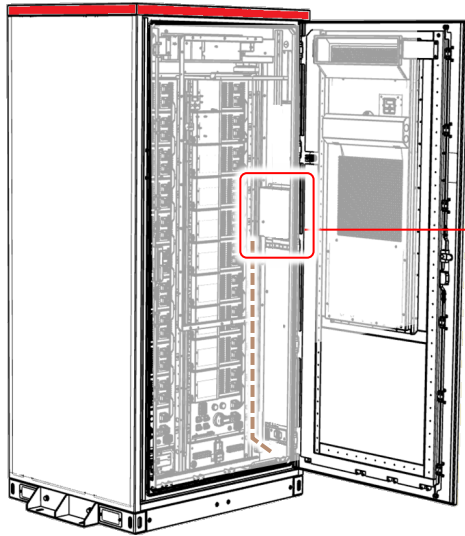

Follow Wiring Procedure

- Connect Remote EPO to the Battery Cabinet Leader using the digital I/O provided in the CSS Local Interface: pin 8 and 10
- Wire all battery cabinet leaders on site with the same method.
- Do not add any additional wiring to 'Follower' batteries.

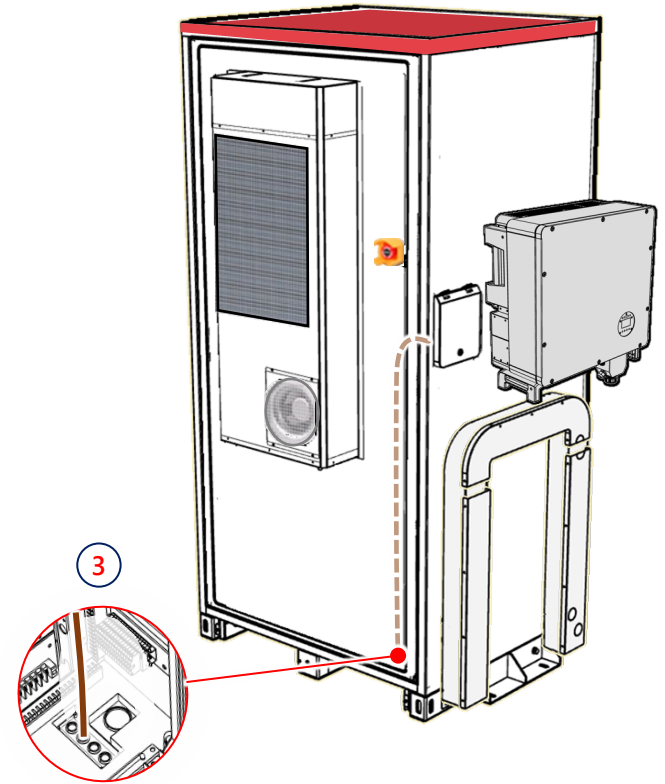
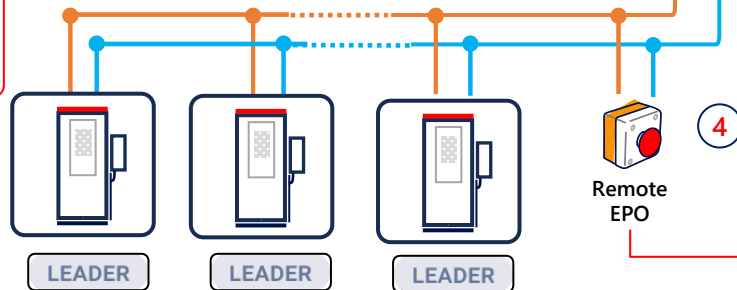

Remote EPO Requirements

- Use only passive Normally Open (N.O), EPO push-button
- The EPO push-button of the Leader Inverter trips all Follower Battery Cabinet(s).
- Recovery duration is 1 second

Follow the numbered steps to power up the system

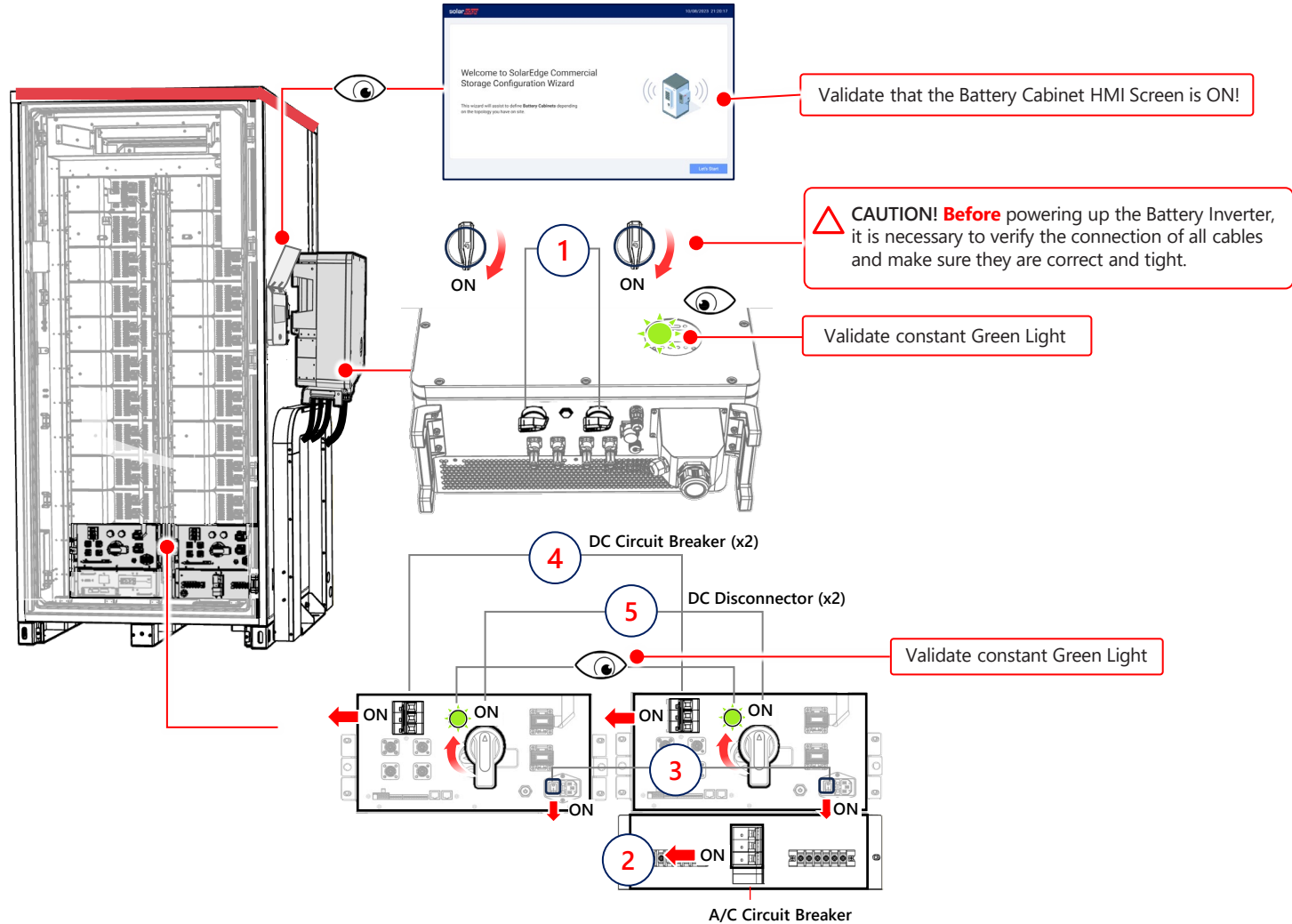

Follow the numbered steps to power down the system

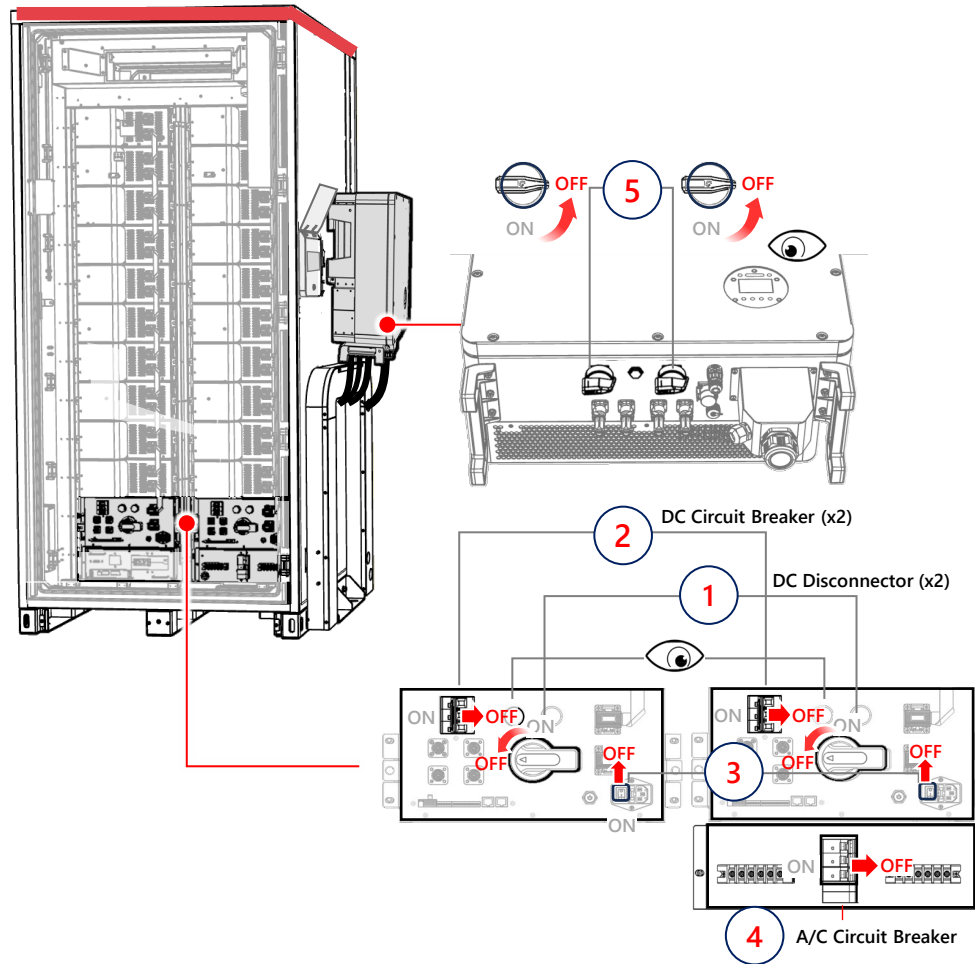



Appendix A

Site Commissioning

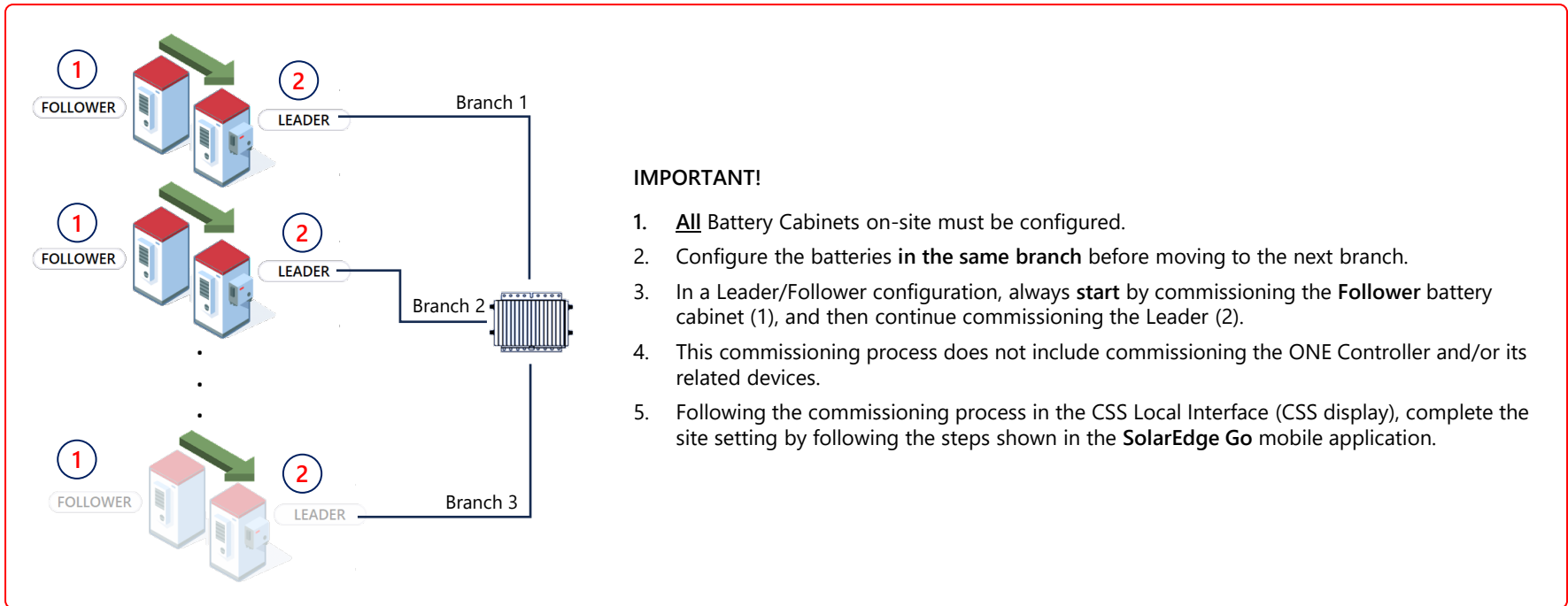

Commissioning the Follower Battery Cabinet

When the cabinet boots, it shows a welcome screen. Tap **Let's Start** to continue.

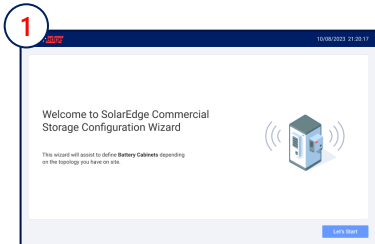

FOLLOWER

For Grid-tied topology, tap **No**.

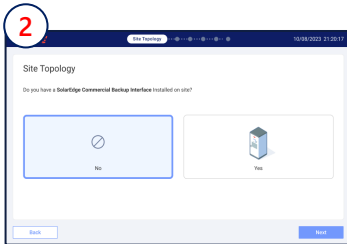

For a Follower Battery Cabinet, tap **No**.

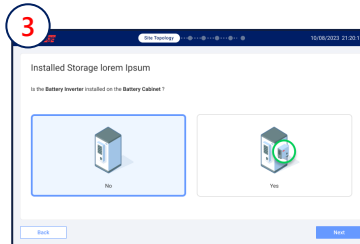

Assign a Follower Battery Cabinet by selecting the **Follower ID** and tapping **Next**.

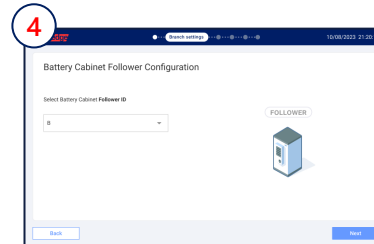

During configuration, **Do Not** close this screen until the configuration is complete.

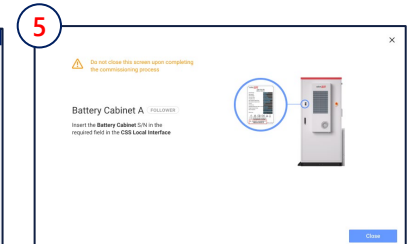

During this process, you will need to enter the S/N of the cabinet. Use the S/N shown on the nameplate.

When the cabinet boots, it shows a welcome screen. Tap **Let's Start** to continue.

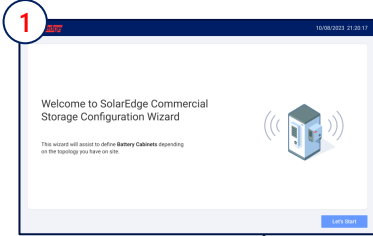

For Grid-tied topology tap **No**.

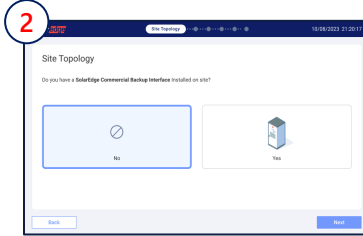

For a Leader Battery Cabinet, tap **Yes**.

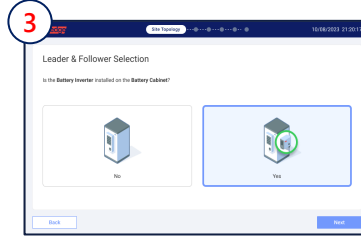

Tap **Confirm** to load a Leader firmware to the Leader Battery Cabinet and reboot.

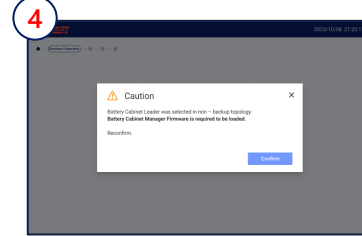

After the Cabinet Leader firmware reboots, self-diagnostics starts automatically.

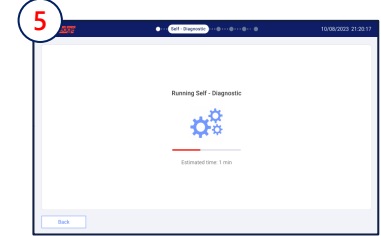

Tap the Battery Cabinets branch length, assign the Leader ID, and tap **Next**.

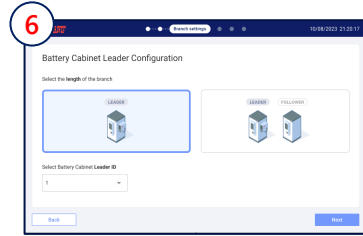

Auto-detection starts automatically

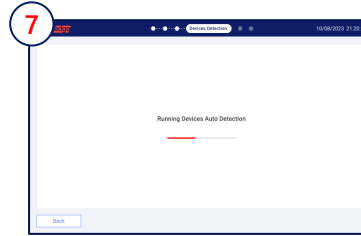

Detected devices and their states are displayed. Enter all **Battery Cabinet S/Ns** and tap **Next** to proceed

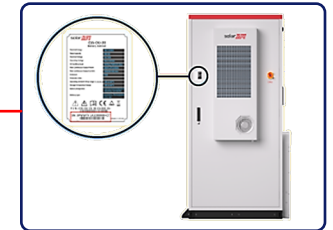
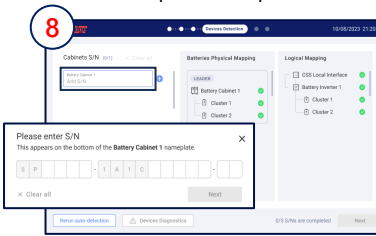

Select the local Grid Code

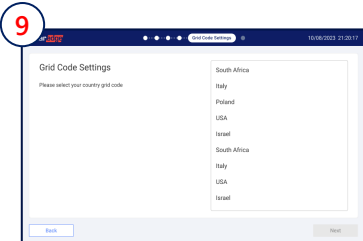

Tap **Finish** to proceed with installation and continue commissioning with the **SolarEdge Go** mobile app.

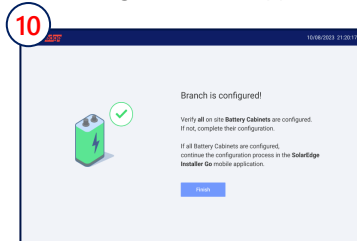

11

Setting Communication

1 Tap Settings on the Home Screen

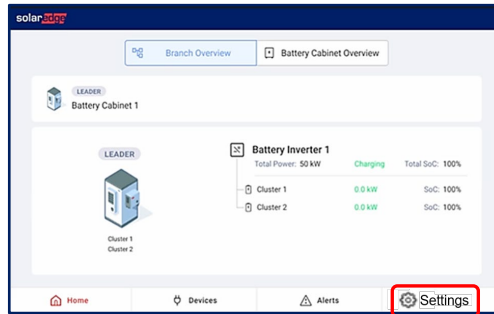

2 Tap General > Network

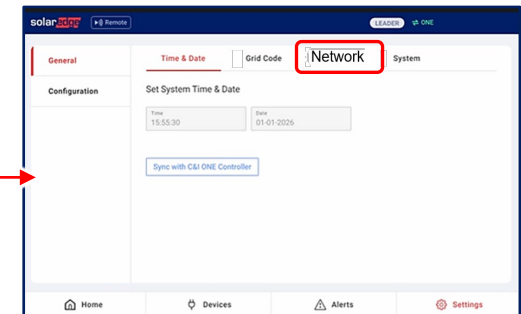

5 Install SolarEdge Go for SolarEdge ONE Controller for C&I Configuration



<https://youtu.be/KVCRGSEq8VU>



4 Tap Accept

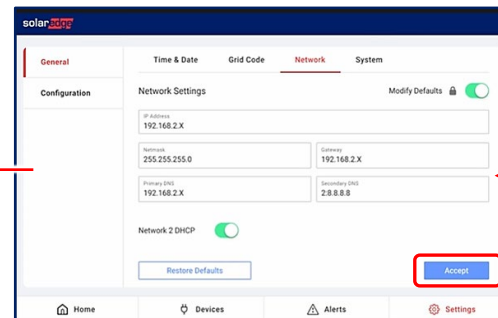

3 Tap Modify Defaults and enter the password > Next

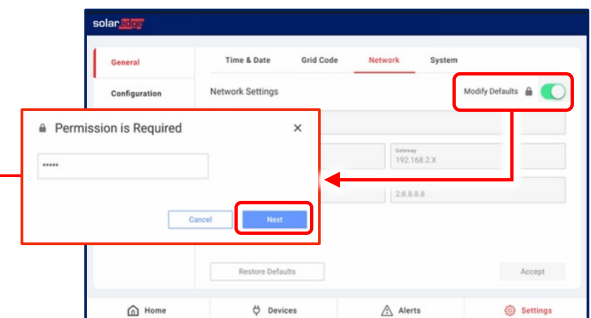



Appendix B

Construction Details

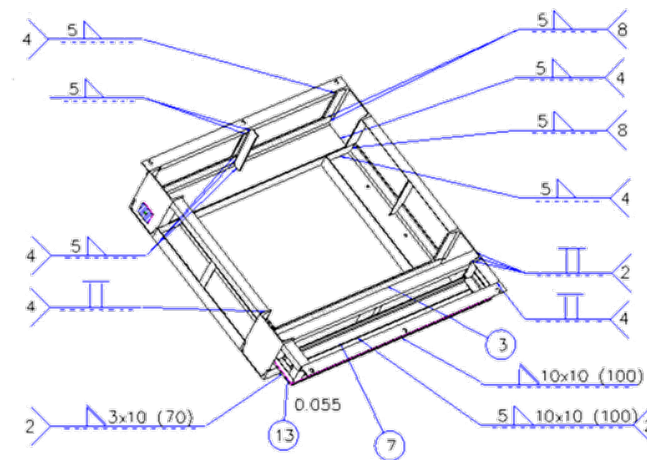
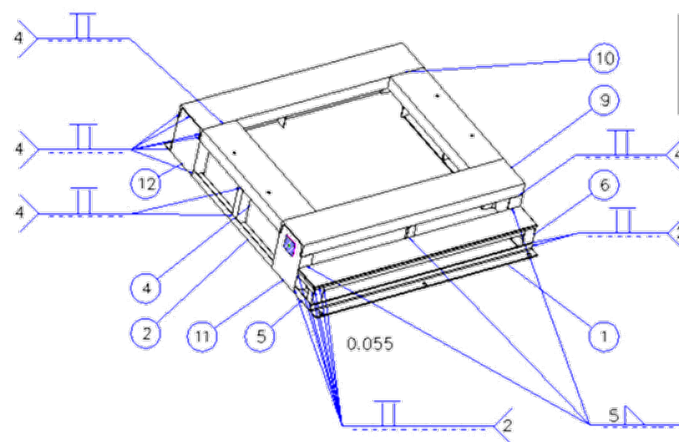
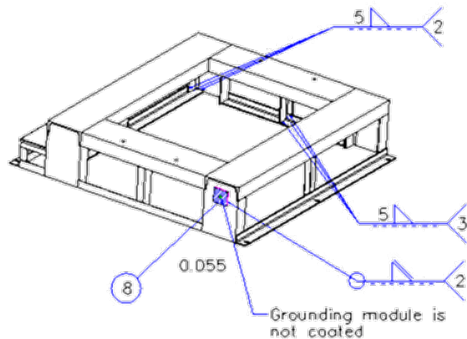

13	footboard	1
12	U-steel D	2
11	U-steel C	2
10	U-steel B	2
9	U-steel A	2
8	Stainless steel grounding module	2
7	Unequal Angle steel G	2
6	Unequal Angle steel F	2
5	Unequal Angle steel	4
4	Unequal Angle steel D	4
3	Unequal Angle steel C	1
2	Unequal Angle steel	2
1	Unequal Angle steel A	2
No	Part Name	qty

Technical Requirements:

1. Solid welding, no virtual welding.
2. After welding, except for welding slag, the outer surface of the parts is polished and smooth.
3. Spray protection according to the requirements of the drawing, all stud end faces and threads need spray protection.
4. No dimensioned tolerance according to GB/T 1804-M processing.
5. The unmarked position tolerance shall be executed in GB/T 1184-K class.
6. With* number is an important size, need to focus on inspection.
7. For other dimensions not specified, refer to the 2D/3D drawing.

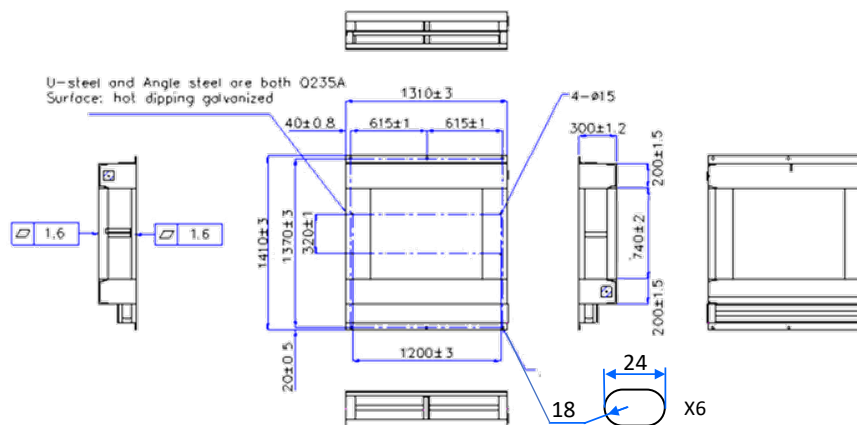

IMPORTANT NOTES!

1. Battery Cabinet must be installed on a reinforced concrete platform base.
2. Dig a trench or reserve a cable entry hole by considering the electrical wiring of the equipment before construction of the foundation.
3. The foundation must be made of non-combustible materials.
4. The bearing capacity of the foundation shall be > 3 t.
5. When designing and manufacturing the embedded steel plates for the battery cabinet, it is necessary to consider that there must be a reliable connection (reinforcement hook) between the embedded steel plate and the concrete base.
6. When molding the concrete pad, it shall protrude below the ground as minimum of 400 mm.
7. To avoid flood damage and safety hazards, the cabinet must be installed on a concrete platform with a minimum height of 300 mm. Concrete base surface smoothness shall be ≤ 3 mm.
8. The upper surface tolerance of the foundation shall be ± 5 mm.
9. The concrete pad shall prevent rainwater accumulation on top of it. The foundation construction should meet the drainage requirements for maximum volume of rainfall in the locality, and the discharged water needs to be treated in accordance with local laws and regulations.
10. The foundation drawing is only for reference and cannot be regarded as the final construction drawing. Operators shall recheck the basic parameters according to the environment, geological conditions, seismic requirements, etc. of the installation site.

Concrete Platform Base

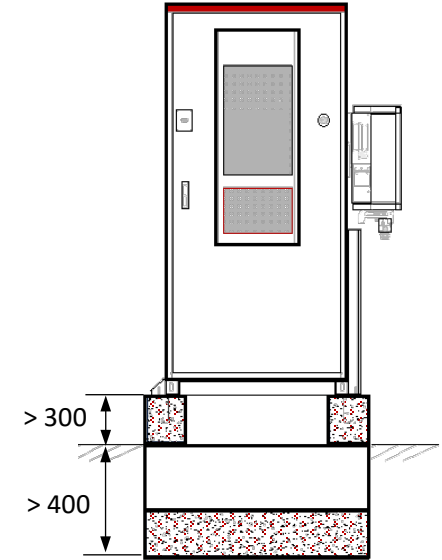
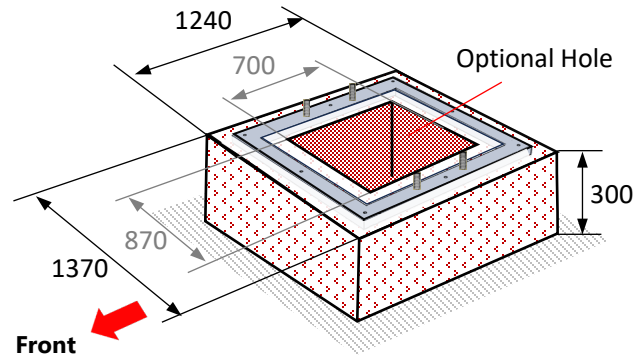

Embedded Steel Plate with Studs

Embedded Steel Plate 100 / 10

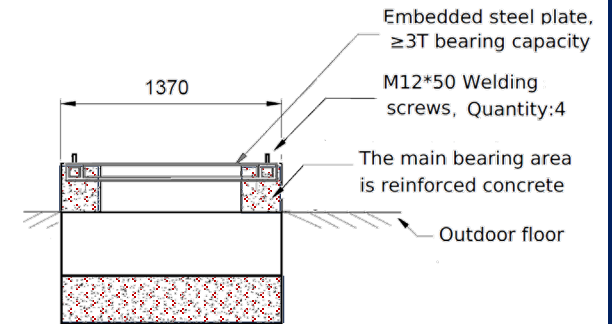
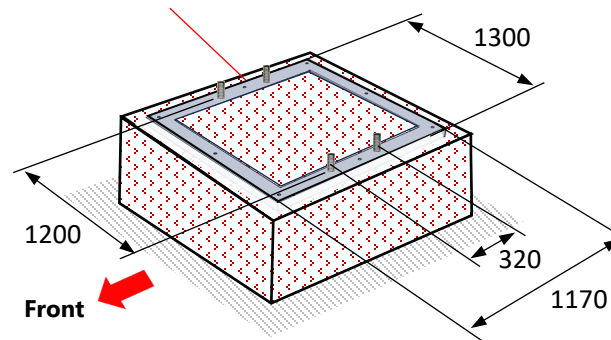

All dimensions are in mm



Appendix C

Troubleshooting and Maintenance







Troubleshooting

Fault Description	Possible Cause	Corrective Action
Grid Overvoltage	Grid voltage above permissible limit	<ul style="list-style-type: none"> • Check Grid Code settings • Check grid voltage with a multimeter. • Contact utility provider if voltage remains high.
Grid Undervoltage	Grid voltage below permissible limit	<ul style="list-style-type: none"> • Verify connection at AC terminals. • Check for utility fluctuations or loose wiring.
Grid Frequency Error	Frequency outside 50/60 Hz ± 0.5 Hz	<ul style="list-style-type: none"> • Confirm local grid frequency stability. • Wait for automatic reconnection once frequency normalizes.
Insulation Resistance Fault	Low insulation resistance detected on DC side	<ul style="list-style-type: none"> • Check for good earth resistance of BT+ and BT- battery terminals is greater than 2 MΩ. • Replace defective module or cable.
Ground Fault	Leakage current detected	<ul style="list-style-type: none"> • Inspect for damaged cables or moisture ingress. • Dry the system and re-test insulation.
Temperature Overheat	Inverter temperature exceeds safe limit	<ul style="list-style-type: none"> • Ensure ambient temperature is within range. • Clean heat sink and check for blocked airflow. • Verify fan operation (if equipped).
Communication Failure	Lost connection with SolarEdge ONE system	<ul style="list-style-type: none"> • Check communication wiring and connectors. • Verify that SolarEdge ONE Controller is powered. • Verify that your site router is powered and connected to the internet.

Maintenance

NOTE: For CSS-OD routine maintenance guide, refer to: <https://knowledge-center.solaredge.com/sites/kc/files/se-css-od-routine-maintenance-guide.pdf>

Battery Inverter LED Indications

LED Indication(s)		Description
All LEDs are Off	 (Running Alarm Fault)	The battery inverter is powered off
Steady Green	 (Running Alarm Fault)	Standard operation
Flashing Yellow and steady Red	 (Running Alarm Fault)	Self-test
Steady Yellow and steady Red	 (Running Alarm Fault)	Standby mode
Steady	 (Running Alarm Fault)	Faulty Inverter (Contact support)
Flashing Red	 (Running Alarm Fault)	Severity level: Inverter fault (Contact support)
Steady Green and flashing Yellow	 (Running Alarm Fault)	Normal operation; state of charge approaching 100% or 0%



Support Contact Information

If you have technical problems concerning SolarEdge products, please contact us:

<https://www.solaredge.com/service/support>

Subject to change without notice.

Copyright © SolarEdge Inc.

All rights reserved. February 2026.