

IDC180E

120/150/180kW Isolated air-cooling fast DC charger



RELIABLE AND SAFE

- IP65 protection and C5 anti-corrosion
- Long lifespan over 10 years
- Carefree maintenance without replacing dust filter mat
- Self-designed and own-manufactured power modules



USER FRIENDLY

- Supports multiple authentication and payment options *
- Charging cable management system for premium user experience



EFFICIENT AND SMART

- Max. efficiency up to 96.5%
- Dynamic load management to optimize EV charging



FLEXIBLE APPLICATION

- Adaptive voltage range 200-920Vdc
- Compatibility with PV-ESS system reserved

CIRCUIT DIAGRAM

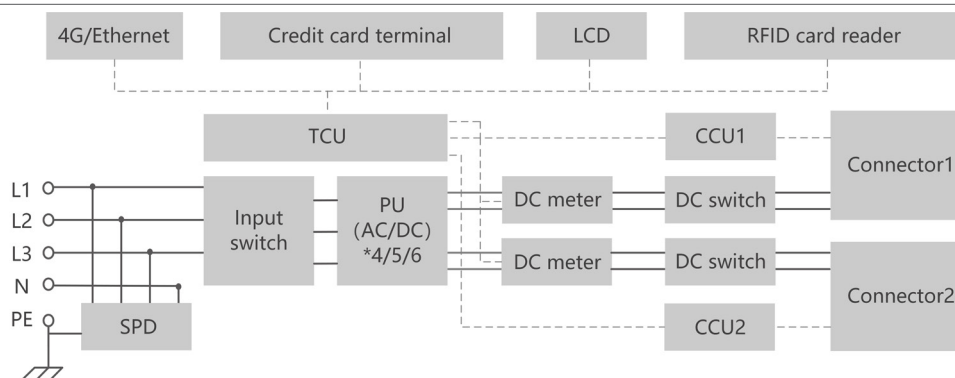

Technical data	IDC180E	
Charging connector		
Connector type	Outlet #1: CCS2 Outlet #2: CCS2	
Number of EV served	2	
Cable length	5 m (standard) 7 m (optional)	
Cable management system	Yes	
EVSE-vehicle protocol	DIN SPEC 70121 ISO 15118	
DC output		
DC output power **	Max. 180 kW *1 or 90 kW * 2 Max. 150 kW *1 or 60 kW + 90 kW Max. 120 kW *1 or 60 kW * 2	
DC output voltage	200 Vdc - 920 Vdc	
DC output current	Outlet #1: CCS2 250 A or 380 A (optional) Outlet #2: CCS2 250 A or 380 A (optional)	
AC input		
Grid voltage	3 / N / PE, 380 Vac / 400 Vac (± 10 %)	
Nominal grid frequency	50 Hz / 60 Hz	
Earthing system	TN-C / TN-S / TN-C-S / TT	
Rated input current	289 A at DC output power 180 kW 241 A at DC output power 150 kW 193 A at DC output power 120 kW	
Power factor	≥ 0.99	
Total harmonic distortion (THDi)	< 5 % at full output power	
Overvoltage category	III	
Standby self-consumption	≤ 48 W	
Efficiency		
Max. efficiency	96.5 %	
Protection		
Overload protection	Yes	
Over/under voltage protection	Yes	
Over-current protection	Yes	
Short-circuit protection	Yes	
Leakage current protection	Yes	
Over-temperature protection	Yes	
Surge protection	Yes	
Emergency stop	Yes	
User interface		
Display	10-inch color touch screen English (standard) Other languages available by firmware upgrade	
Language	RFID-card / Plug & play / Auto-charge (standard) Plug & charge / Debit or credit-card (optional)	
Authentication	OTA (over-the-air) by iEnergyCharge	
Firmware update	ISO / IEC 14443 A / B ISO / IEC 15693	
RFID system	MID-certified meter integrated Eichrecht / PTB-certified meter integrated (optional)	
Energy metering	WLAN / Ethernet / 4G	
Communication interface	OCPP 1.6J Ready for OCPP 2.0.1	
Communication protocol (charger-to-CSMS)	Mechanical data	
Dimensions (W*H*D)	930 mm * 1930 mm * 615 mm	
Weight	≤ 500 kg ***	
Installation method	Floor mounted	
AC cable specification	Max. 240 mm ²	
Environmental data		
Enclosure rating	IP65	
Anti-corrosion degree	C5	
Mechanical impact protection	IK10 ****	
Operating ambient temperature range	-35 °C - 55 °C	
Allowable relative humidity range	5 % - 95 % (non-condensing)	
Max. operating altitude	≤ 2000 m	
Cooling method	Smart forced air cooling ≤ 65 dB (A) at 1 m distance / 25 °C , at full output power	
Noise (typical)		
Certification and standards		
Certifications	CE, CB, UKCA, RCM, ADQCC, MoIAT, PEA, SASO, MEW	
Compliance	ETSI / EN 300 328, EN 300 330, EN 301 489-1 / 3 / 17 / 52, ETSI / EN 301 908-1 / 13, EN 50665, BS / EN IEC 61851-1, BS / EN IEC 61851-21-2, BS / IEC EN 61851-23 / 24, EN IEC 62311	
Warranty	3 years (standard)	

* Payment terminal is an optional feature. Please consult Sungrow for more information.

** The output power of IDC180E is configurable at power modules level.

*** The weight varies from 440 kg up to 500 kg according to the quantity of power modules.

**** The mechanical impact protection degree of HMI is IK08.