

SUN2000-(30K, 40K)-MC0 Series

User Manual

Issue 04
Date 2026-01-15



Copyright © Huawei Technologies Co., Ltd. 2026. All rights reserved.

No part of this document may be reproduced or transmitted in any form or by any means without prior written consent of Huawei Technologies Co., Ltd.

Trademarks and Permissions



HUAWEI and other Huawei trademarks are trademarks of Huawei Technologies Co., Ltd.

All other trademarks and trade names mentioned in this document are the property of their respective holders.

Notice

The purchased products, services and features are stipulated by the contract made between Huawei and the customer. All or part of the products, services and features described in this document may not be within the purchase scope or the usage scope. Unless otherwise specified in the contract, all statements, information, and recommendations in this document are provided "AS IS" without warranties, guarantees or representations of any kind, either express or implied.

The information in this document is subject to change without notice. Every effort has been made in the preparation of this document to ensure accuracy of the contents, but all statements, information, and recommendations in this document do not constitute a warranty of any kind, express or implied.

Huawei Technologies Co., Ltd.

Address: Huawei Industrial Base
Bantian, Longgang
Shenzhen 518129
People's Republic of China

Website: <https://e.huawei.com>

About This Document

Purpose

This document describes the following inverter models (also referred to as SUN2000) in terms of the safety precautions, product introduction, installation, electrical connections, power-on and commissioning, maintenance, and technical specifications. Read this document carefully before installing and operating the inverter.

- SUN2000-30K-MC0
- SUN2000-40K-MC0



Intended Audience



This document is intended for:

- Technical support engineers
- Hardware installation engineers
- Commissioning engineers
- Maintenance engineers

Symbol Convention

The symbols that may be found in this document are defined as follows.

Symbol	Description
 DANGER	Indicates a hazard with a high level of risk which, if not avoided, will result in death or serious injury.
 WARNING	Indicates a hazard with a medium level of risk which, if not avoided, could result in death or serious injury.
 CAUTION	Indicates a hazard with a low level of risk which, if not avoided, could result in minor or moderate injury.

Symbol	Description
 NOTICE	Indicates a potentially hazardous situation which, if not avoided, could result in equipment damage, data loss, performance deterioration, or unanticipated results. NOTICE is used to address practices not related to personal injury.
 NOTE	Supplements the important information in the main text. NOTE is used to address information not related to personal injury, equipment damage, and environment deterioration.

Change History

Changes between document issues are cumulative. The latest document issue contains all the changes made in earlier issues.

Issue 04 (2026-01-15)

Updated [2.2.1 Typical Networking](#).

Updated [7.3.1.3 Quick Settings](#).

Issue 03 (2025-11-28)

Updated [2.2.1 Typical Networking](#).

Updated [7.3.1.3 Quick Settings](#).

Updated [7.3.2.2 Setting Function and Feature Parameters](#).

Updated [7.3.2.2.2 Setting Feed-in at Limited Current](#).

Updated [7.3.2.2.5 Setting Dry Contact Scheduling](#).

Updated [A Grid Codes](#).

Issue 02 (2025-09-18)

Updated [2.2.1 Typical Networking](#).

Updated [5.4 Connecting an AC Output Power Cable](#).

Updated [7.3.1.3 Quick Settings](#).

Updated [8.1 Routine Maintenance](#).

Issue 01 (2025-08-30)

This issue is used for first office application (FOA).

Contents

About This Document.....	ii
1 Safety Information.....	1
1.1 Personal Safety.....	2
1.2 Electrical Safety.....	4
1.3 Environment Requirements.....	7
1.4 Mechanical Safety.....	8
2 Overview.....	13
2.1 Model Number Description.....	13
2.2 Networking Application.....	13
2.2.1 Typical Networking.....	14
2.2.1.1 RS485 Networking.....	14
2.2.2 Earthing Systems.....	16
2.3 Appearance.....	17
2.4 Circuit Diagram.....	19
2.5 Working Modes.....	20
2.6 Label Description.....	22
3 Inverter Storage.....	24
4 Installation.....	26
4.1 Installation Modes.....	26
4.2 Installation Requirements.....	27
4.2.1 Site Selection Requirements.....	27
4.2.2 Clearance Requirements.....	29
4.2.3 Angle Requirements.....	31
4.3 Tools.....	32
4.4 Checking Before Installation.....	34
4.5 Moving the Inverter.....	35
4.6 Installing the Inverter on a Wall.....	36
4.7 Installing the Inverter on a Support.....	38
5 Electrical Connections.....	41
5.1 Precautions.....	41
5.2 Preparing Cables.....	42

5.3 Connecting a PE Cable.....	45
5.4 Connecting an AC Output Power Cable.....	46
5.5 Connecting DC Input Power Cables.....	52
5.5.1 Cable Connection Description.....	53
5.5.2 Measuring the Insulation Resistance of PV Strings to the Ground.....	55
5.5.2.1 Optimizers Configured.....	55
5.5.2.2 Optimizers Not Configured.....	58
5.5.3 Connecting Cables to Amphenol Helios H4 Terminals.....	61
5.6 Installing the Smart Dongle.....	65
5.6.1 4G Smart Dongle.....	65
5.6.2 WLAN-FE Smart Dongle.....	67
5.7 Connecting Signal Cables.....	68
5.7.1 Scenario Where Signal Cables Are Connected.....	68
5.7.1.1 Connecting the RS485 Communications Cable (Inverter Cascading).....	71
5.7.1.2 Connecting the RS485 Communications Cables (SmartLogger).....	72
5.7.1.3 Connecting the RS485 Communications Cable (Power Meter).....	74
5.7.1.4 Connecting the Grid Scheduling Signal Cable.....	75
5.7.1.5 Connecting the Rapid Shutdown Signal Cable.....	77
5.7.1.6 Connecting the NS Protection Signal Cable.....	79
5.7.2 Scenario Where No Signal Cable Is Connected.....	80
6 Check Before Power-On.....	82
7 Power-On and Commissioning.....	83
7.1 Powering On the Inverter.....	83
7.2 Commissioning Methods and Process.....	86
7.3 Commissioning the Inverter (Using the App).....	86
7.3.1 Creating a Plant.....	86
7.3.1.1 Downloading and Installing the FusionSolar App.....	86
7.3.1.2 Registering an Installer Account.....	86
7.3.1.3 Quick Settings.....	87
7.3.1.4 Creating a Plant.....	90
7.3.1.5 Registering an Owner Account.....	90
7.3.2 Setting Functions and Features Through Device Commissioning.....	90
7.3.2.1 Connecting to the Inverter on the App.....	90
7.3.2.2 Setting Function and Feature Parameters.....	90
7.3.2.2.1 Setting Grid-tied Point Control.....	91
7.3.2.2.2 Setting Feed-in at Limited Current.....	91
7.3.2.2.3 Setting Output Apparent Power Control.....	96
7.3.2.2.4 Setting RCD Parameters.....	97
7.3.2.2.5 Setting Dry Contact Scheduling.....	98
7.3.2.2.6 Setting PV String Access Detection.....	100
7.3.2.2.7 Setting Built-in PID Recovery.....	102
7.3.2.3 AFCI.....	103

7.3.3 Viewing the Plant Status.....	104
8 System Maintenance.....	106
8.1 Routine Maintenance.....	106
8.2 Powering Off the System.....	109
8.3 Locating Insulation Resistance Faults.....	109
9 Alarm Reference.....	114
10 Handling the Inverter.....	115
10.1 Removing the SUN2000.....	115
10.2 Packing the SUN2000.....	115
10.3 Disposing of the SUN2000.....	115
11 Technical Specifications.....	116
A Grid Codes.....	121
B Connecting to a Device on the App (the Device Supports WLAN).....	132
C Crimping an OT or DT Terminal.....	135
D Rapid Shutdown.....	138
E Setting the Physical Layout of Smart PV Optimizers.....	139
F Smart I-V Curve Diagnosis.....	140
G Resetting a Password.....	141
G.1 Power-On and Power-Off.....	141
G.2 Resetting the Password After Connecting to the Device and Obtaining the Verification Code.....	142
G.3 Resetting the Password After Obtaining the Verification Code and Connecting to the Device.....	144
G.4 Resetting the Password on the SmartLogger WebUI.....	145
H Contact Information.....	147
I Digital Power Customer Service.....	149
J Certificate Management and Maintenance.....	150
J.1 Initial Certificate Risk Disclaimer.....	150
J.2 Application Scenarios of Initial Certificates.....	151
K Acronyms and Abbreviations.....	152

1 Safety Information

Statement

Before transporting, storing, installing, operating, using, and/or maintaining the equipment, read this document, strictly follow the instructions provided herein, and follow all the safety instructions on the equipment and in this document. In this document, "equipment" refers to the products, software, components, spare parts, and/or services related to this document; "the Company" refers to the manufacturer (producer), seller, and/or service provider of the equipment; "you" refers to the entity that transports, stores, installs, operates, uses, and/or maintains the equipment.

The **Danger, Warning, Caution, and Notice** statements described in this document do not cover all the safety precautions. You also need to comply with relevant international, national, or regional standards and industry practices. **The Company shall not be liable for any consequences that may arise due to violations of safety requirements or safety standards concerning the design, production, and usage of the equipment.**

The equipment shall be used in an environment that meets the design specifications. Otherwise, the equipment may be faulty, malfunctioning, or damaged, which is not covered under the warranty. The Company shall not be liable for any property loss, personal injury, or even death caused thereby.

Comply with applicable laws, regulations, standards, and specifications during transportation, storage, installation, operation, use, and maintenance.

Do not perform reverse engineering, decompilation, disassembly, adaptation, implantation, or other derivative operations on the equipment software. Do not study the internal implementation logic of the equipment, obtain the source code of the equipment software, violate intellectual property rights, or disclose any of the performance test results of the equipment software.

The Company shall not be liable for any of the following circumstances or their consequences:

- The equipment is damaged due to force majeure such as earthquakes, floods, volcanic eruptions, debris flows, lightning strikes, fires, wars, armed conflicts, typhoons, hurricanes, tornadoes, and other extreme weather conditions.
- The equipment is operated beyond the conditions specified in this document.

- The equipment is installed or used in environments that do not comply with international, national, or regional standards.
- The equipment is installed or used by unqualified personnel.
- You fail to follow the operation instructions and safety precautions on the product and in the document.
- You remove or modify the product or modify the software code without authorization.
- You or a third party authorized by you cause the equipment damage during transportation.
- The equipment is damaged due to storage conditions that do not meet the requirements specified in the product document.
- You fail to prepare materials and tools that comply with local laws, regulations, and related standards.
- The equipment is damaged due to your or a third party's negligence, intentional breach, gross negligence, or improper operations, or other reasons not related to the Company.

1.1 Personal Safety

 **DANGER**

Ensure that power is off during installation. Do not install or remove a cable with power on. Transient contact between the core of the cable and the conductor will generate electric arcs or sparks, which may cause a fire or personal injury.

 **DANGER**

Non-standard and improper operations on the energized equipment may cause fire, electric shocks, or explosion, resulting in property damage, personal injury, or even death.

 **DANGER**

Before operations, remove conductive objects such as watches, bracelets, bangles, rings, and necklaces to prevent electric shocks.

 **DANGER**

During operations, use dedicated insulated tools to prevent electric shocks or short circuits. The dielectric withstanding voltage level must comply with local laws, regulations, standards, and specifications.

 **WARNING**

During operations, wear personal protective equipment such as protective clothing, insulated shoes, goggles, safety helmets, and insulated gloves.

Figure 1-1 Personal protective equipment

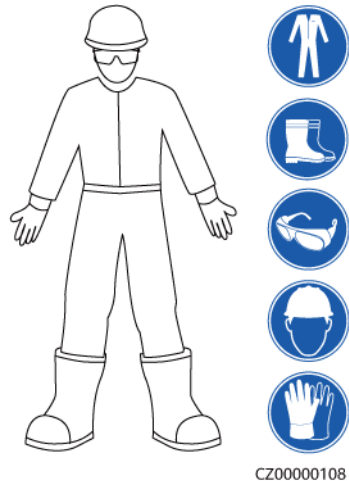

General Requirements

- Do not stop protective devices. Pay attention to the warnings, cautions, and related precautionary measures in this document and on the equipment.
- If there is a likelihood of personal injury or equipment damage during operations, immediately stop, report the case to the supervisor, and take feasible protective measures.
- Do not power on the equipment before it is installed or confirmed by professionals.
- Do not touch the power supply equipment directly or with conductors such as damp objects. Before touching any conductor surface or terminal, measure the voltage at the contact point to ensure that there is no risk of electric shock.
- Do not touch operating equipment because the enclosure is hot.
- Do not touch a running fan with your hands, components, screws, tools, or boards. Otherwise, personal injury or equipment damage may occur.
- In the case of a fire, immediately leave the building or the equipment area and activate the fire alarm or call emergency services. Do not enter the affected building or equipment area under any circumstances.

Personnel Requirements

- Only professionals and trained personnel are allowed to operate the equipment.
 - Professionals: personnel who are familiar with the working principles and structure of the equipment, trained or experienced in equipment operations and are clear of the sources and degree of various potential hazards in equipment installation, operation, maintenance

- Trained personnel: personnel who are trained in technology and safety, have required experience, are aware of possible hazards on themselves in certain operations, and are able to take protective measures to minimize the hazards on themselves and other people
- Personnel who plan to install or maintain the equipment must receive adequate training, be able to correctly perform all operations, and understand all necessary safety precautions and local relevant standards.
- Only qualified professionals or trained personnel are allowed to install, operate, and maintain the equipment.
- Only qualified professionals are allowed to remove safety facilities and inspect the equipment.
- Personnel who will perform special tasks such as electrical operations, working at heights, and operations of special equipment must possess the required local qualifications.
- Only authorized professionals are allowed to replace the equipment or components (including software).
- Only personnel who need to work on the equipment are allowed to access the equipment.

1.2 Electrical Safety

 **DANGER**

Before connecting cables, ensure that the equipment is intact. Otherwise, electric shocks or fire may occur.

 **DANGER**

Non-standard and improper operations may result in fire or electric shocks.

 **DANGER**

Prevent foreign matter from entering the equipment during operations. Otherwise, equipment short-circuits or damage, load power derating, power failure, or personal injury may occur.

 **WARNING**

For the equipment that needs to be grounded, install the ground cable first when installing the equipment and remove the ground cable last when removing the equipment.

WARNING

During the installation of PV strings and the inverter, the positive or negative terminals of PV strings may be short-circuited to ground if the power cables are not properly installed or routed. In this case, an AC or DC short circuit may occur and damage the inverter. The resulting device damage is not covered under any warranty.

CAUTION

Do not route cables near the air intake or exhaust vents of the equipment.

General Requirements

- Follow the procedures described in the document for installation, operation, and maintenance. Do not reconstruct or alter the equipment, add components, or change the installation sequence without permission.
- Obtain approval from the national or local electric utility company before connecting the equipment to the grid.
- Observe the power plant safety regulations, such as the operation and work ticket mechanisms.
- Install temporary fences or warning ropes and hang "No Entry" signs around the operation area to keep unauthorized personnel away from the area.
- Before installing or removing power cables, turn off the switches of the equipment and its upstream and downstream switches.
- Before performing operations on the equipment, check that all tools meet the requirements and record the tools. After the operations are complete, collect all of the tools to prevent them from being left inside the equipment.
- Before installing power cables, check that cable labels are correct and cable terminals are insulated.
- When installing the equipment, use a torque tool of a proper measurement range to tighten the screws. When using a wrench to tighten the screws, ensure that the wrench does not tilt and the torque error does not exceed 10% of the specified value.
- Ensure that bolts are tightened with a torque tool and marked in red and blue after double-check. Installation personnel mark tightened bolts in blue. Quality inspection personnel confirm that the bolts are tightened and then mark them in red. (The marks must cross the edges of the bolts.)

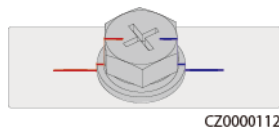

- If the equipment has multiple inputs, disconnect all the inputs and wait until the equipment is completely powered off before performing operations on the equipment.
- Before maintaining a downstream electrical or power distribution device, turn off the output switch on the power supply equipment.

- During equipment maintenance, attach "Do not switch on" labels near the upstream and downstream switches or circuit breakers as well as warning signs to prevent accidental connection. The equipment can be powered on only after troubleshooting is complete.
- Do not open equipment panels.
- Check equipment connections periodically, ensuring that all screws are securely tightened.
- Only qualified professionals can replace a damaged cable.
- Do not scrawl, damage, or block any labels or nameplates on the equipment. Promptly replace labels that have worn out.
- Do not use solvents such as water, alcohol, or oil to clean electrical components inside or outside of the equipment.
- The surge protection of the PV system and the building where the PV system is installed shall comply with local standards.

Grounding

- Ensure that the grounding impedance of the equipment complies with local electrical standards.
- Ensure that the equipment is connected permanently to the protective ground. Before operating the equipment, check its electrical connection to ensure that it is reliably grounded.
- Do not work on the equipment in the absence of a properly installed ground conductor.
- Do not damage the ground conductor.

Cabling Requirements

- When selecting, installing, and routing cables, follow local safety regulations and rules.
- When routing power cables, ensure that there is no coiling or twisting. Do not join or weld power cables. If necessary, use a longer cable.
- Ensure that all cables are properly connected and insulated, and meet specifications.
- Ensure that the slots and holes for routing cables are free from sharp edges, and that the positions where cables are routed through pipes or cable holes are equipped with cushion materials to prevent the cables from being damaged by sharp edges or burrs.
- Ensure that cables of the same type are bound together neatly and straight and that the cable sheath is intact. When routing cables of different types, ensure that they are away from each other without entanglement and overlapping.
- Secure buried cables using cable supports and cable clips. Ensure that the cables in the backfill area are in close contact with the ground to prevent cable deformation or damage during backfilling.
- If the external conditions (such as the cable layout or ambient temperature) change, verify the cable usage in accordance with the IEC-60364-5-52 or local laws and regulations. For example, check that the current-carrying capacity meets requirements.

- When routing cables, reserve at least 30 mm clearance between the cables and heat-generating components or areas. This prevents deterioration or damage to the cable insulation layer.

1.3 Environment Requirements

 **DANGER**

Do not expose the equipment to flammable or explosive gas or smoke. Do not perform any operation on the equipment in such environments.

 **DANGER**

Do not store any flammable or explosive materials in the equipment area.

 **DANGER**

Do not place the equipment near heat sources or fire sources, such as smoke, candles, heaters, or other heating devices. Overheat may damage the equipment or cause a fire.

 **WARNING**

Install the equipment in an area far away from liquids. Do not install it under areas prone to condensation, such as under water pipes and air exhaust vents, or areas prone to water leakage, such as air conditioner vents, ventilation vents, or feeder windows of the equipment room. Ensure that no liquid enters the equipment to prevent faults or short circuits.

 **WARNING**

To prevent damage or fire due to high temperature, ensure that the ventilation vents or heat dissipation systems are not obstructed or covered by other objects while the equipment is running.

General Requirements

- Store the equipment according to the storage requirements. Equipment damage caused by unqualified storage conditions is not covered under the warranty.
- Keep the installation and operating environments of the equipment within the allowed ranges. Otherwise, its performance and safety will be compromised.

- The operating temperature range provided in the equipment's technical specifications refers to the ambient temperatures in equipment's installation environment.
- Do not install, use, or operate outdoor equipment and cables (including but not limited to moving equipment, operating equipment and cables, inserting connectors to or removing connectors from signal ports connected to outdoor facilities, working at heights, performing outdoor installation, and opening doors) in harsh weather conditions such as lightning, rain, snow, and level 6 or stronger wind.
- Do not install the equipment in an environment with dust, smoke, volatile or corrosive gases, infrared and other radiations, organic solvents, or salty air.
- Do not install the equipment in an environment with conductive metal or magnetic dust.
- Do not install the equipment in an area conducive to the growth of microorganisms such as fungus or mildew.
- Do not install the equipment in an area with strong vibration, noise, or electromagnetic interference.
- Ensure that the site complies with local laws, regulations, and related standards.
- Ensure that the ground in the installation environment is solid, free from spongy or soft soil, and not prone to subsidence. The site must not be located in a low-lying land prone to water or snow accumulation, and the horizontal level of the site must be above the highest water level of that area in history.
- Do not install the equipment in a position that may be submerged in water.
- If the equipment is installed in a place with abundant vegetation, in addition to routine weeding, harden the ground underneath the equipment using cement or gravel (the area shall be greater than or equal to 3 m x 2.5 m).
- Do not install the equipment outdoors in salt-affected areas because it may be corroded. A salt-affected area refers to the region within 500 m of the coast or prone to sea breeze. Regions prone to sea breeze vary with weather conditions (such as typhoons and monsoons) or terrains (such as dams and hills).
- Before installation, operation, and maintenance, clean up any water, ice, snow, or other foreign objects on the top of the equipment.
- When installing the equipment, ensure that the installation surface is solid enough to bear the weight of the equipment.
- After installing the equipment, remove the packing materials such as cartons, foam, plastics, and cable ties from the equipment area.

1.4 Mechanical Safety

 **WARNING**

Ensure that all necessary tools are ready and inspected by a professional organization. Do not use tools that have signs of scratches or fail to pass the inspection or whose inspection validity period has expired. Ensure that the tools are secure and not overloaded.

 **WARNING**

Do not drill holes into the equipment. Doing so may affect the sealing performance and electromagnetic containment of the equipment and damage components or cables inside. Metal shavings from drilling may short-circuit boards inside the equipment.

General Requirements

- Repaint any paint scratches caused during equipment transportation or installation in a timely manner. Equipment with scratches must not be exposed for an extended period of time.
- Do not perform operations such as arc welding and cutting on the equipment without evaluation by the Company.
- Do not install other devices on the top of the equipment without evaluation by the Company.
- When performing operations over the top of the equipment, take measures to protect the equipment against damage.
- Use correct tools and operate them in the correct way.

Moving Heavy Objects

- Be cautious to prevent injury when moving heavy objects.



< 18 kg
(< 40 lbs)



18–32 kg
(40–70 lbs)



32–55 kg
(70–121 lbs)

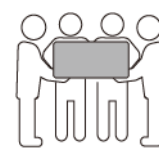

55–68 kg
(121–150 lbs)



> 68 kg
(> 150 lbs)

CZ0000110

- If multiple persons need to move a heavy object together, determine the manpower and work division with consideration of height and other conditions to ensure that the weight is equally distributed.
- If two persons or more move a heavy object together, ensure that the object is lifted and landed simultaneously and moved at a uniform pace under the supervision of one person.
- Wear personal protective gears such as protective gloves and shoes when manually moving the equipment.
- To move an object by hand, approach to the object, squat down, and then lift the object gently and stably by the force of the legs instead of your back. Do not lift it suddenly or turn your body around.
- Do not quickly lift a heavy object above your waist. Place the object on a workbench that is half-waist high or any other appropriate place, adjust the positions of your palms, and then lift it.
- Move a heavy object stably with balanced force at an even and low speed. Put down the object stably and slowly to prevent any collision or drop from scratching the surface of the equipment or damaging the components and cables.

- When moving a heavy object, be aware of the workbench, slope, staircase, and slippery places. When moving a heavy object through a door, ensure that the door is wide enough to move the object and avoid bumping or injury.
- When transferring a heavy object, move your feet instead of turning your waist around. When lifting and transferring a heavy object, ensure that your feet point to the target direction of movement.
- When transporting the equipment using a pallet truck or forklift, ensure that the tynes are properly positioned so that the equipment does not topple. Before moving the equipment, secure it to the pallet truck or forklift using ropes. When moving the equipment, assign dedicated personnel to take care of it.
- Choose sea, roads in good conditions, or airplanes for transportation. Do not transport the equipment by railway. Avoid tilt or jolt during transportation.

Using Ladders

- Use wooden or insulated ladders when you need to perform live-line working at heights.
- Platform ladders with protective rails are preferred. Single ladders are not recommended.
- Before using a ladder, check that it is intact and confirm its load bearing capacity. Do not overload it.
- Ensure that the ladder is securely positioned and held firm.



CZ00000107

- When climbing up the ladder, keep your body stable and your center of gravity between the side rails, and do not overreach to the sides.
- When a step ladder is used, ensure that the pull ropes are secured.
- If a single ladder is used, the recommended angle for the ladder against the floor is 75 degrees, as shown in the following figure. A square can be used to measure the angle.

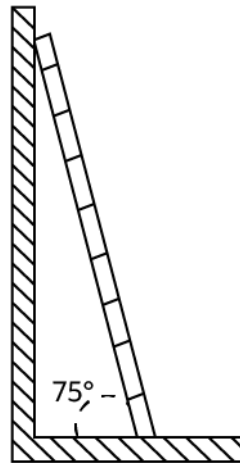

PI02SC0008

- If a single ladder is used, ensure that the wider end of the ladder is at the bottom, and take protective measures to prevent the ladder from sliding.
- If a single ladder is used, do not climb higher than the fourth rung of the ladder from the top.
- If you use a single ladder to climb up to a platform, ensure that the ladder is at least 1 m higher than the platform.

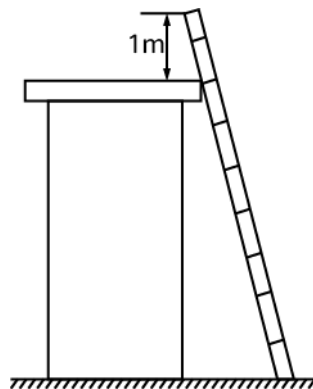

PI02SC0009

Hoisting

- Only trained and qualified personnel are allowed to perform hoisting operations.
- Install temporary warning signs or fences to isolate the hoisting area.
- Ensure that the foundation where hoisting is performed on meets the load-bearing requirements.
- Before hoisting objects, ensure that hoisting tools are firmly secured onto a fixed object or wall that meets the load-bearing requirements.
- During hoisting, do not stand or walk under the crane or the hoisted objects.
- Do not drag steel ropes and hoisting tools or bump the hoisted objects against hard objects during hoisting.
- Ensure that the angle between two hoisting ropes is no more than 90 degrees, as shown in the following figure.

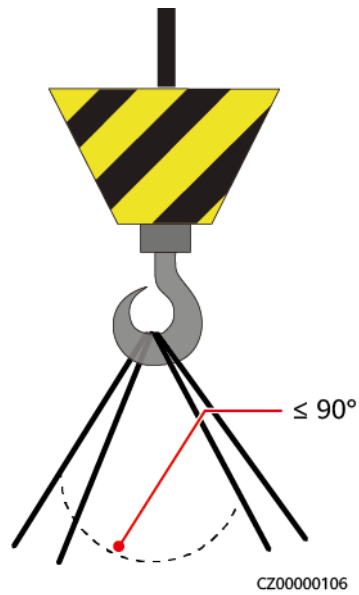

Drilling Holes

- Obtain consent from the customer and contractor before drilling holes.
- Wear protective equipment such as safety goggles and protective gloves when drilling holes.
- To avoid short circuits or other risks, do not drill holes into buried pipes or cables.
- When drilling holes, protect the equipment from shavings. After drilling, clean up any shavings.

2 Overview

The SUN2000 is a three-phase grid-tied PV string inverter that converts the DC power generated by PV modules into AC power and feeds the electricity into the power grid.

2.1 Model Number Description

This document involves the following product models:

- SUN2000-30K-MC0
- SUN2000-40K-MC0

Figure 2-1 Model number

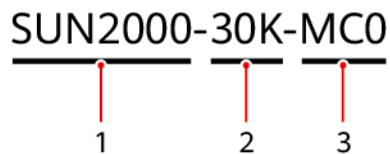





Table 2-1 Model number description

No.	Meaning	Description
1	Product family identifier	SUN2000: grid-tied PV inverter
2	Power level identifier	<ul style="list-style-type: none">• 30K: The rated power is 30 kW.• 40K: The rated power is 40 kW.
3	Product series identifier	MC0: product series with an input voltage level of 1100 V DC

2.2 Networking Application

2.2.1 Typical Networking

- The SUN2000 supports RS485 communication but not AC MBUS communication.
- The SUN2000 supports optimizer connection.
- In the networking diagram,  indicates the power cable,  indicates the power flow direction, and  and  indicate the signal flow.

2.2.1.1 RS485 Networking

NOTICE

- A maximum of 30 SUN2000s can be cascaded to each COM port on the SmartLogger, and a maximum of 10 SUN2000s can be cascaded to the Dongle.
 - If the SmartLogger3000A or SmartLogger3000B is used, the RS485 communication distance between the SUN2000 at the end and the SmartLogger must be less than or equal to 1000 m (baud rate: 9600 bit/s).
 - If the SmartLogger5000B or SmartMGC5000B is used, the RS485 communication distance between the SUN2000 at the end and the SmartLogger must be as follows:
 - ≤ 1000 m (baud rate: 9600 bit/s)
 - ≤ 500 m (baud rate: 38400 bit/s)
-

Figure 2-2 RS485 networking (SmartLogger)

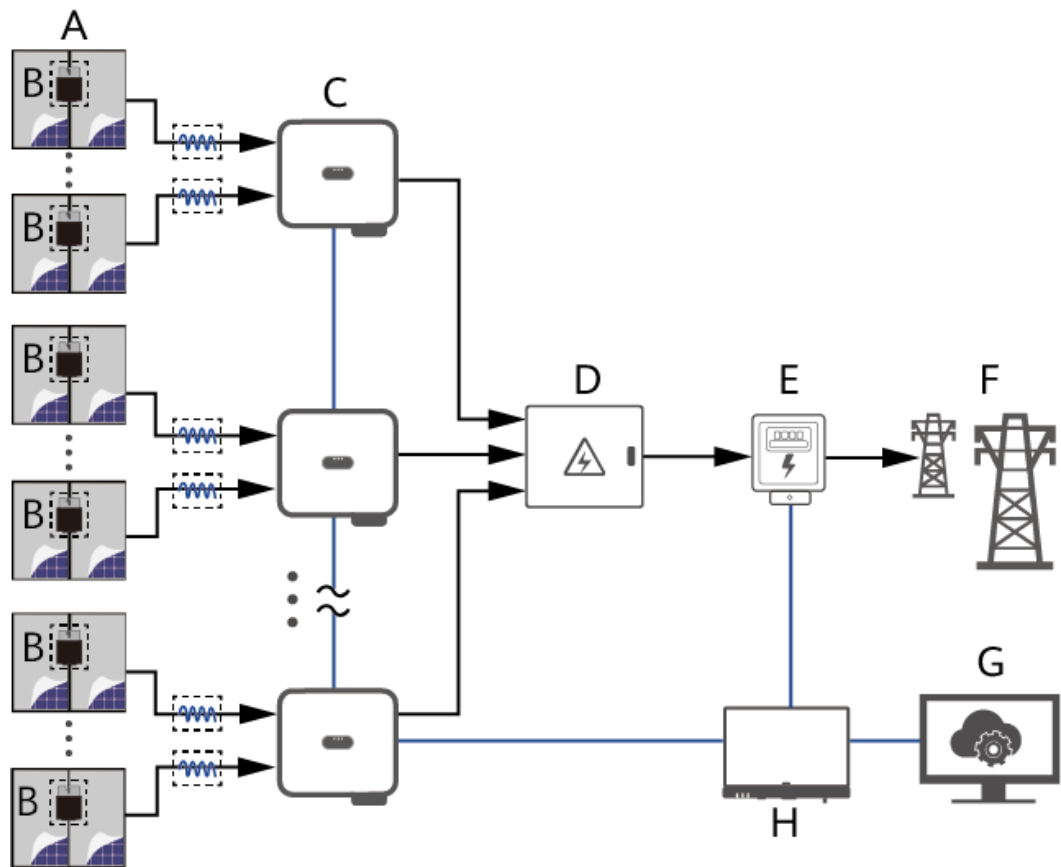

(A) PV string	(B) Optimizer ^a (optional)	(C) SUN2000
(D) AC combiner box	(E) Smart Power Sensor ^b	(F) Power grid
(G) Management system	(H) SmartLogger ^c	-

Note a: The signal flow  between the PV string and the inverter is displayed only if optimizers are configured for the PV string.

Note b: The Smart Power Sensor is also called a power meter.

Note c: The SmartLogger3000A, SmartLogger3000B, SmartLogger5000B, or SmartMGC5000B can be used. (If the SmartLogger3000A or SmartLogger3000B is used, the software version must be SmartLogger V300R024C10SPC260 or later.)

Figure 2-3 RS485 networking (Dongle)

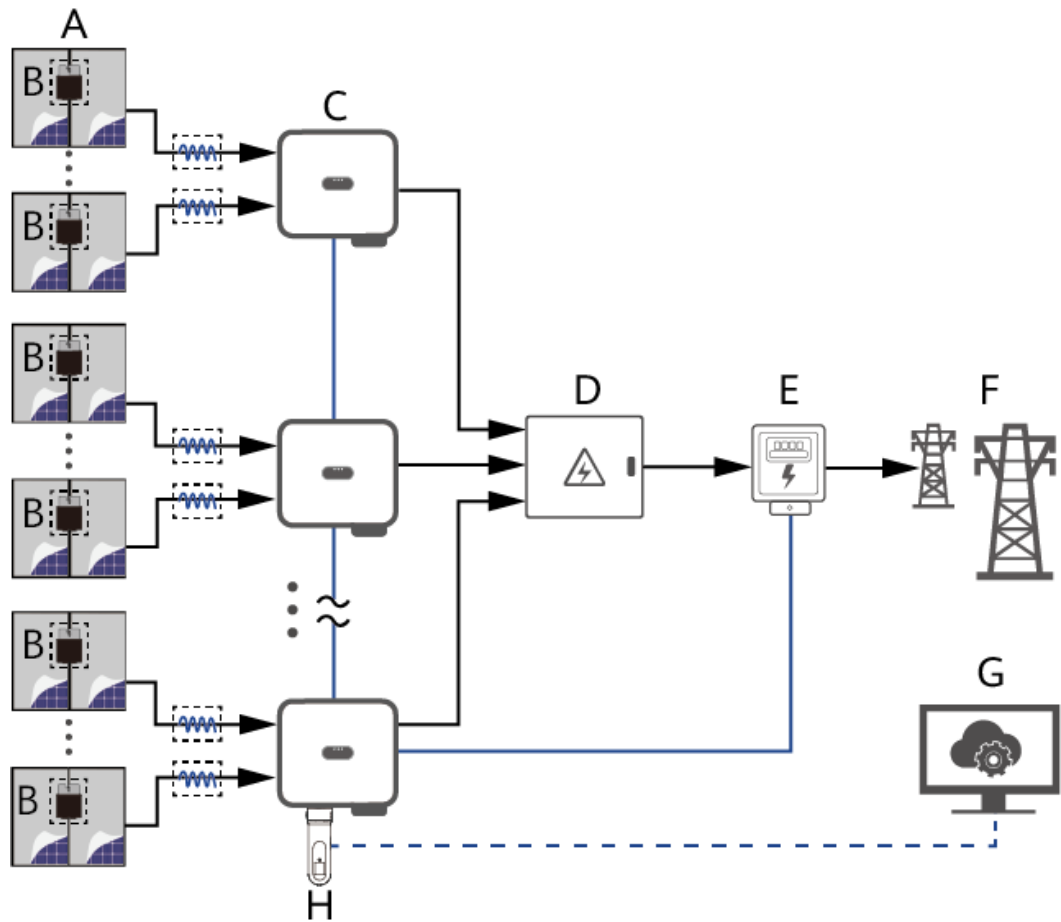

(A) PV string	(B) Optimizer ^a (optional)	(C) SUN2000
(D) AC combiner box	(E) Smart Power Sensor ^b	(F) Power grid
(G) Management system	(H) Dongle	-
<p>Note a: The signal flow  between the PV string and the inverter is displayed only if optimizers are configured for the PV string.</p> <p>Note b: The Smart Power Sensor is also called a power meter.</p>		

2.2.2 Earthing Systems

The SUN2000 supports the TN-S, TN-C, TN-C-S, TT, and IT earthing systems.

Figure 2-4 Earthing systems

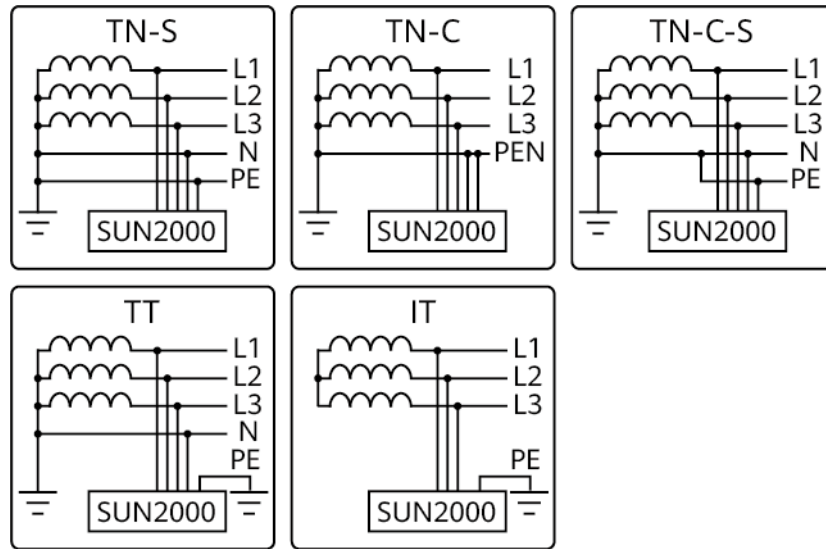

IS12W00005

2.3 Appearance

Figure 2-5 Appearance

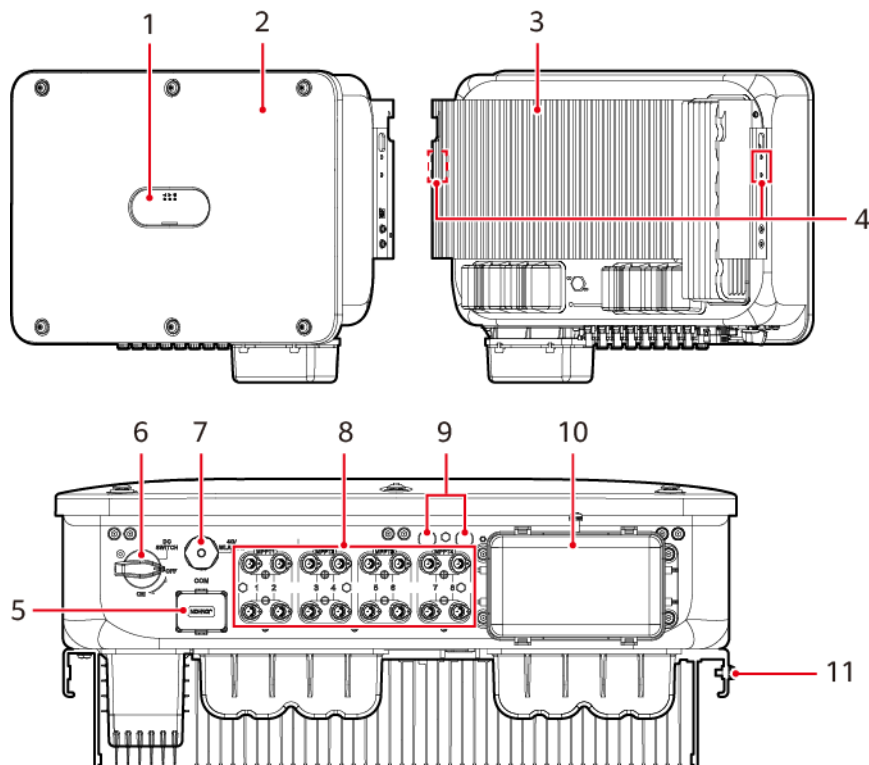

(1) LED indicators

(2) Front panel



(3) Heat sink

(4) Screw holes for fixing the sunshade

- (5) Communications port (COM)
- (6) DC switch (DC SWITCH)
- (7) Smart Dongle port (4G/WLAN-FE)
- (8) DC input terminals (PV1–PV8)
- (9) Ventilation valves
- (10) AC output ports
- (11) Ground point

Indicator Description

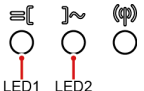
Table 2-2 LED indicator description

Category	Status		Description
Running indication 	LED1	LED2	-
	Steady green	Steady green	The inverter is running in on-grid state.
	Blinking green slowly (on for 1s and off for 1s)	Off	The DC is on and the AC is off.
	Blinking green slowly (on for 1s and off for 1s)	Blinking green slowly (on for 1s and off for 1s)	Both the DC and AC are on, and the inverter is off-grid.
	Off	Blinking green slowly (on for 1s and off for 1s)	The DC is off and the AC is on.
	Off	Off	Both the DC and AC are off.
	Blinking red fast (on for 0.2s and off for 0.2s)	-	There is a DC environmental alarm.
	-	Blinking red fast (on for 0.2s and off for 0.2s)	There is an AC environmental alarm.
	Steady red	Steady red	A fault exists.
Communi cation indication 	LED3		-
	Blinking green fast (on for 0.2s and off for 0.2s)		Communication is in progress.
Blinking green slowly (on for 1s and off for 1s)		A mobile phone is connected to the inverter.	

Category	Status			Description
	Off			There is no communication.
Device replacement indication	LED1	LED2	LED3	-
	Steady red	Steady red	Steady red	The inverter hardware is faulty and needs to be replaced.

DC SWITCH Description

Table 2-3 DC switch description

Switch	Description	
DC SWITCH	ON	The DC switch is on.
	OFF	The DC switch is off.

Figure 2-6 DC SWITCH

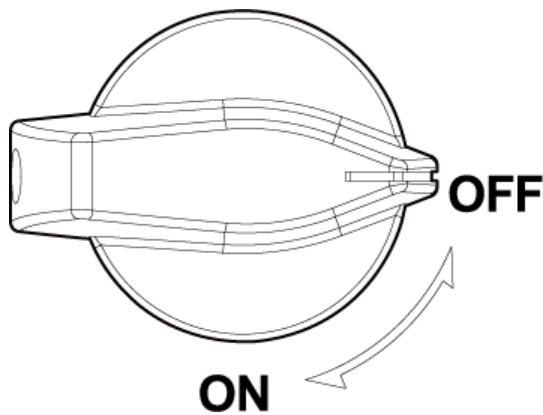

2.4 Circuit Diagram

The SUN2000 receives inputs from eight PV strings. Then the inputs are grouped into four MPPT circuits inside the SUN2000, with each MPPT circuit tracking the maximum power point of two PV strings. The DC power is then converted into single-phase AC power through an inverter circuit. Surge protection is supported on both the DC and AC sides.

Figure 2-7 Schematic diagram

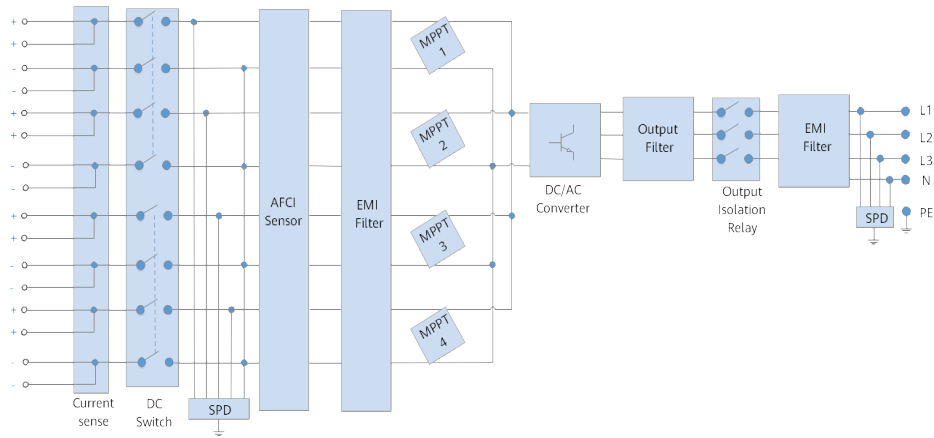

2.5 Working Modes

The SUN2000 can work in Standby, Operating, or Shutdown mode.

Figure 2-8 Working modes

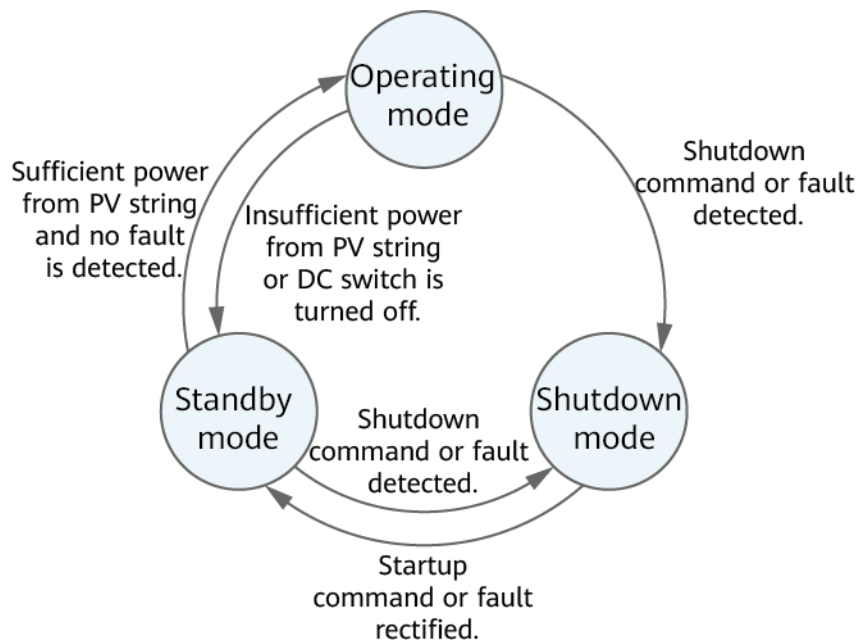

IS07500001



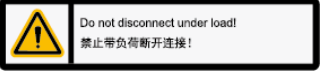



Table 2-4 Working mode description

Working Mode	Description
Standby	<p>The SUN2000 enters Standby mode when the external environment does not meet the operating requirements. In Standby mode:</p> <ul style="list-style-type: none">• The SUN2000 continuously performs status check and enters the Operating mode once the operating requirements are met.• The SUN2000 enters Shutdown mode after detecting a shutdown command or a fault after startup.
Operating	<p>In Operating mode:</p> <ul style="list-style-type: none">• The SUN2000 converts DC power from PV strings into AC power and feeds the power to the power grid.• The SUN2000 tracks the maximum power point to maximize the PV string output.• If the SUN2000 detects a fault or a shutdown command, it enters the Shutdown mode.• The SUN2000 enters Standby mode after detecting that the PV string output power is not suitable for connecting to the power grid for generating power.
Shutdown	<ul style="list-style-type: none">• In Standby or Operating mode, the SUN2000 enters Shutdown mode after detecting a fault or shutdown command.• In Shutdown mode, the SUN2000 enters Standby mode after detecting a startup command or that the fault is rectified.

2.6 Label Description

Table 2-5 Enclosure labels

Symbol	Name	Meaning
	Delayed discharge	<ul style="list-style-type: none"> High voltage exists after the inverter is powered on. Only qualified and trained electrical technicians are allowed to perform operations on the inverter. Residual voltage exists after the inverter is powered off. It takes 5 minutes for the inverter to discharge to a safe voltage.
	High temperature hazard	Do not touch the inverter when it is running because its enclosure is hot.
	Electric shock warning	<ul style="list-style-type: none"> High voltage exists after the inverter is powered on. Only qualified and trained electrical technicians are allowed to perform operations on the inverter. High touch current exists after the inverter is powered on. Before powering on the inverter, ensure that it is properly grounded.

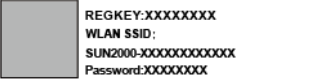
Symbol	Name	Meaning
	Refer to documentation	Reminds operators to refer to the documentation provided with the device. Losses caused by operations that do not comply with the requirements of site selection, storage, or mounting specified in the user manual are not covered under the warranty.
	Protective earthing	Indicates the position for connecting the protective earthing (PE) cable.
	Operation warning	Do not remove the DC input connector or AC output connector with power on.
	Device weight	The inverter is heavy and must be carried by three persons.
	Inverter handle scalding warning	Do not touch the handles until 10 minutes after the inverter is shut down.
	Inverter SN	Indicates the inverter serial number.
	QR code for inverter WLAN connection	Scan the QR code to connect to the inverter WLAN.

3 Inverter Storage

NOTICE

- Store devices according to the storage requirements. Device damage caused by unqualified storage conditions is not covered under the warranty.
- Do not store the devices without outer packaging.

The following requirements shall be met if inverters are not put into use immediately:

- Do not remove the outer packaging. Check the packaging regularly (recommended: once every three months). Replace any packaging that is damaged during storage.
- If an inverter is unpacked but will not be used immediately, put it back to the original packaging with the desiccant, and seal it with tape.
- Inverters must be stored in a clean and dry environment with appropriate temperature and humidity. The air must not contain corrosive or flammable gases.

Figure 3-1 Storage temperature and humidity

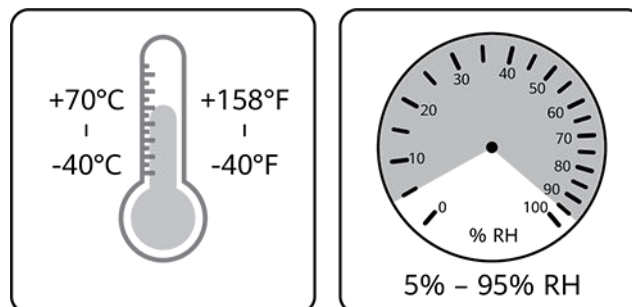

IS07W00011

- When temporarily storing inverters outdoors, do not stack them on a pallet. Take rainproof measures such as using tarpaulins to protect inverters from rain and water.
- Do not tilt a packing case or place it upside down.
- To avoid personal injury or device damage, stack inverters with caution to prevent them from falling over.

Figure 3-2 Maximum number of stacking layers (In the figure, N indicates the maximum number of stacking layers.)

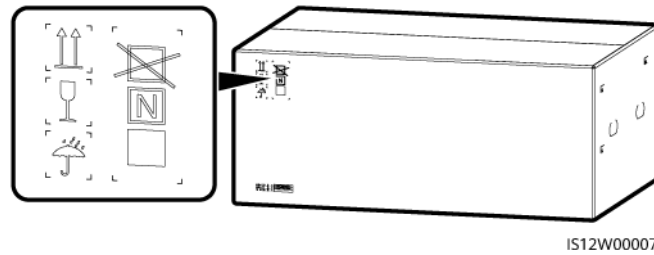

- Do not store inverters for more than two years. If inverters have been stored for two years or longer, they must be checked and tested by professionals before being put into use.
- If an inverter has not been running for six months or longer after being mounted, it may have failed and must be checked and tested by professionals before being put into operation.

4 Installation

4.1 Installation Modes

The inverter can be wall-mounted or support-mounted.

Table 4-1 Installation modes

Installation Mode	Screw Specifications	Description
Wall mounting	M12x60 stainless steel expansion anchor bolt	Delivered with the product
Support mounting	M12x40 bolt assembly	Delivered with the mounting bracket. If the length does not meet the installation requirements, the customer shall prepare M12 bolt assemblies and install them together with the M12 nuts delivered with the product.

 **NOTE**

- The mounting bracket is delivered with the inverter. It is required regardless of whether the inverter is wall-mounted or support-mounted.
- Before installing the mounting bracket, remove the torx key and keep it for later use.

Figure 4-1 Position for binding the torx key

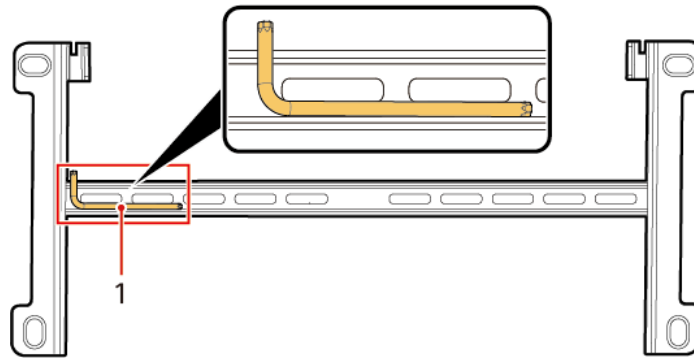

(1) Torx key

4.2 Installation Requirements

4.2.1 Site Selection Requirements

Installation Environment Requirements

- Keep the inverter out of reach of children.
- The inverter is protected to IP66 and can be installed indoors or outdoors.
- Do not install the inverter in working or living areas to avoid personal injury or property loss caused by accidental contact by non-professionals or other reasons during device operation.
- Do not install the inverter in noise-sensitive areas (such as residential areas, office areas, and schools) to avoid complaints. If the preceding areas are unavoidable, the distance between the installation position and noise-sensitive areas must be greater than 40 m. Alternatively, use other low-noise models.
- If the device is installed in public places (such as parking lots, stations, and factories) other than working and living areas, install a protective net outside the device and set up a safety warning sign to isolate the device. This is to avoid personal injury or property loss caused by accidental contact by non-professionals or other reasons during device operation.
- If the equipment is installed in a place with abundant vegetation, in addition to routine weeding, harden the ground underneath the equipment using cement or gravel (the area shall be greater than or equal to 3 m x 2.5 m).
- Do not install the equipment in an area with strong vibration, noise, or electromagnetic interference. The equipment shall be installed in an environment with a magnetic field strength less than 4 Gauss. If the magnetic field strength is greater than or equal to 4 Gauss, the equipment may fail to work properly. If the magnetic field strength is high, for example, in a smeltery, you are advised to use a gauss meter to measure the magnetic field strength of the equipment installation position when the smelting equipment is running normally.

- Do not install the inverter in areas containing flammable materials (such as sulfur, phosphorus, liquefied petroleum gas, marsh gas, flour, and cotton) to avoid personal injury or property loss caused by fire or other reasons.
- Do not install the inverter in areas containing explosives (such as blasting agents, display shells, fireworks, and firecrackers) to avoid personal injury or property loss caused by explosion or other reasons.
- Do not install the inverter in areas with corrosive substances (such as sulfuric acid, hydrochloric acid, nitric acid, hydrogen sulfide, and chlorine) to avoid inverter failure caused by corrosion, which is not covered under the warranty.
- Avoid installing inverters in easily accessible locations, as they operate at a high voltage and their enclosures and heat sinks become hot during use.
- The inverter provides self-protection in high-temperature environments. Its energy yield may decrease as the ambient temperature increases. Ensure that the following installation requirements are met:
 - Install the inverter in a well-ventilated environment to ensure good heat dissipation.
 - If the inverter is installed in an enclosed environment, the heat dissipation equipment or ventilation equipment shall be installed. The indoor ambient temperature must not be higher than the outdoor ambient temperature.
 - You are advised to install the device in a sheltered place or install an awning over it to avoid direct sunlight.
 - Reserve sufficient clearance around the inverter for installation and heat dissipation.
- The inverter will become corroded if installed in areas exposed to salt. Before installing the inverter outdoors in such areas, consult with the Company. A salt-affected area refers to the region within 500 m of the coast or prone to sea breeze. Regions prone to sea breeze vary with weather conditions (such as typhoons and monsoons) or terrains (such as dams and hills).

Mounting Structure Requirements

- The mounting structure for the inverter must be fireproof. Do not install the inverter on flammable building materials to avoid personal injury or property loss caused by fire or other reasons.
- Ensure that the installation surface is solid enough to bear the weight of the inverter to avoid personal injury or property loss caused by the collapse of the mounting structure or other reasons.
- In residential areas, do not install the inverter on plaster board walls or walls made of similar materials with a weak sound insulation performance because the noise generated by the inverter may interfere with residents.

4.2.2 Clearance Requirements

Dimensions

Figure 4-2 Dimensions

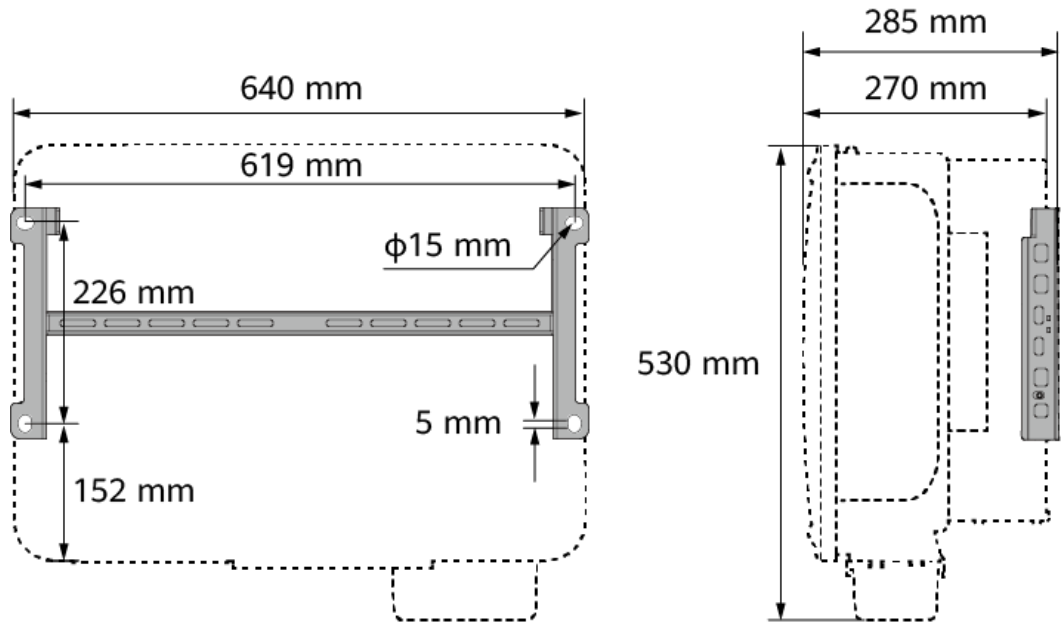

Installation Clearances for a Single Device

Reserve sufficient clearance around the inverter for installation and heat dissipation.

Figure 4-3 Clearances

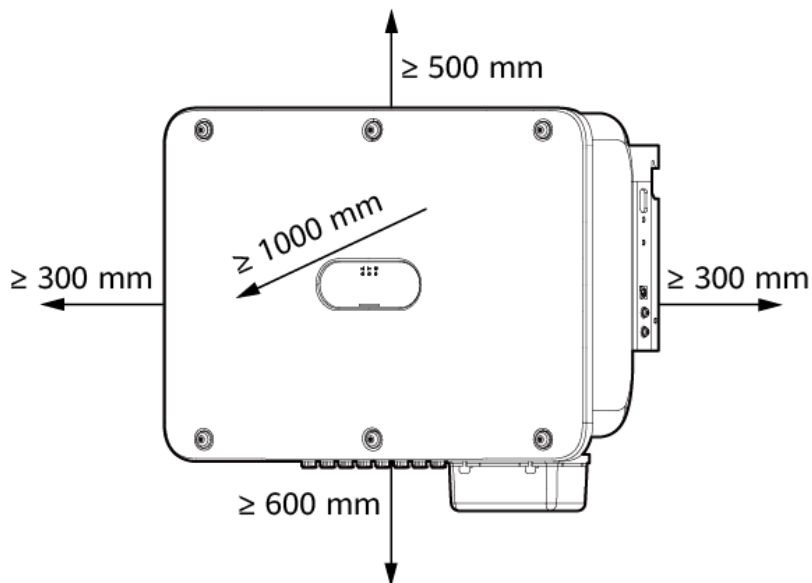

Installation Clearances for Multiple Devices

- If sufficient space is available, install multiple devices in horizontal mode.

Figure 4-4 Horizontal installation (recommended)

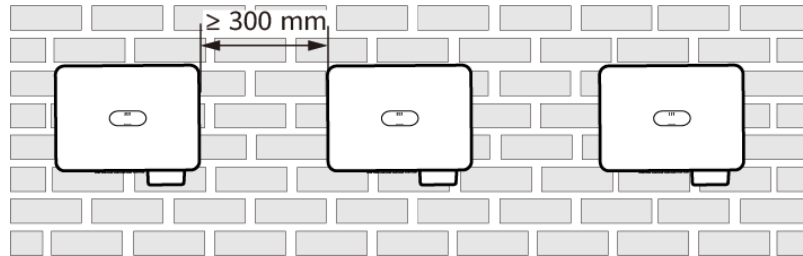

- If no sufficient space is available, install multiple devices in triangle mode.

Figure 4-5 Two-layer triangle installation (recommended)

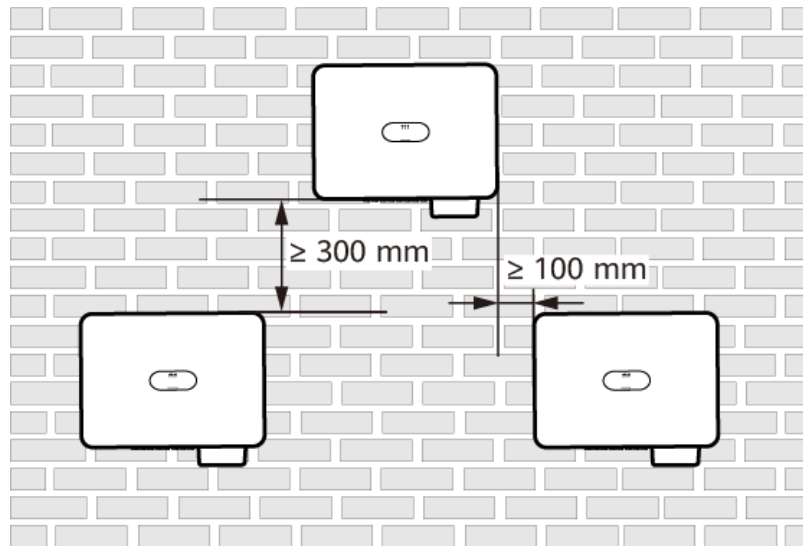

- Stacked installation is not recommended.

Figure 4-6 Three-layer triangle installation (not recommended)

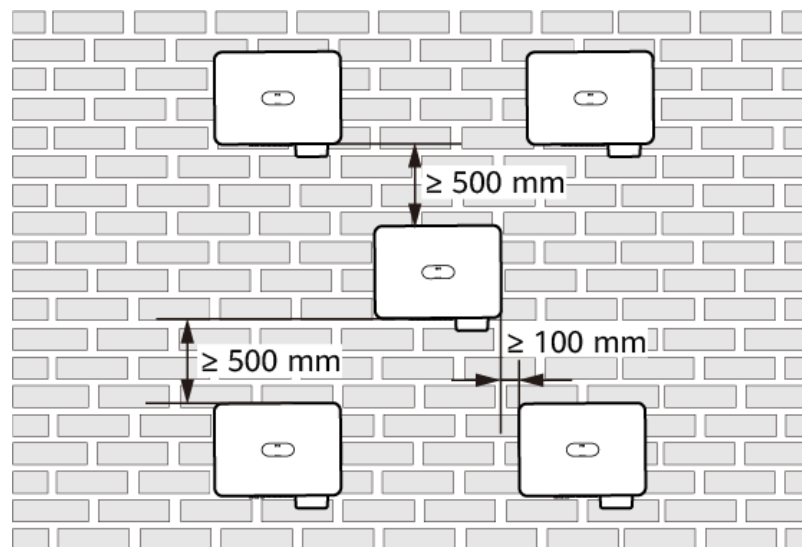

Figure 4-7 Stacked installation on a wall (not recommended)

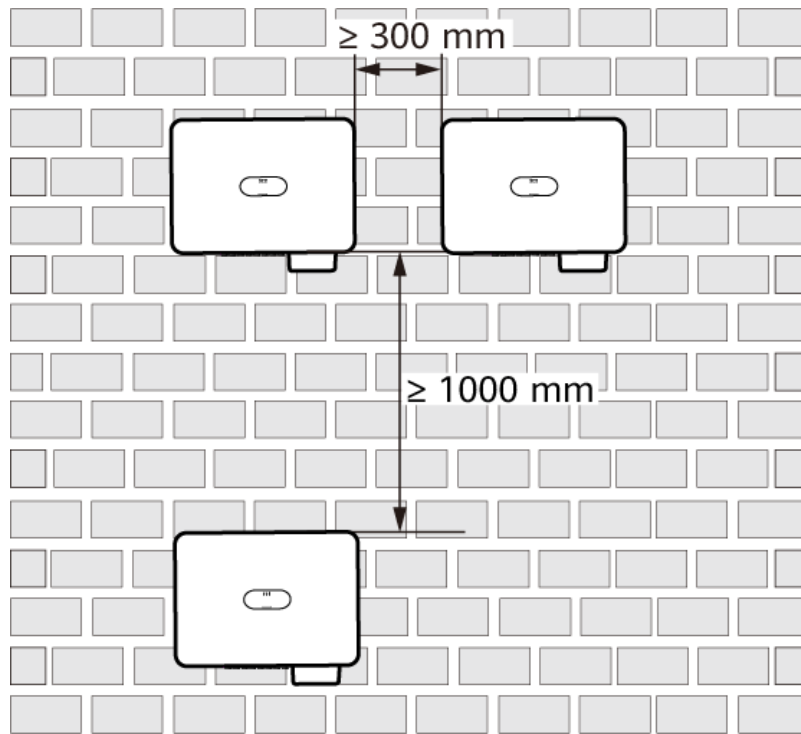
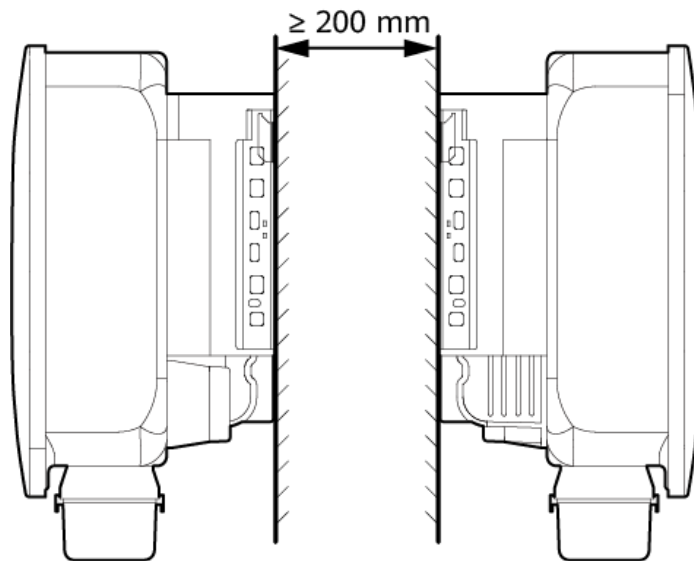

Figure 4-8 Back-to-back installation on a wall (not recommended)



NOTE

The installation figures are for reference only and are irrelevant to the inverter cascading scenario.

4.2.3 Angle Requirements





The inverter can be wall-mounted or support-mounted. The installation angle requirements are as follows:

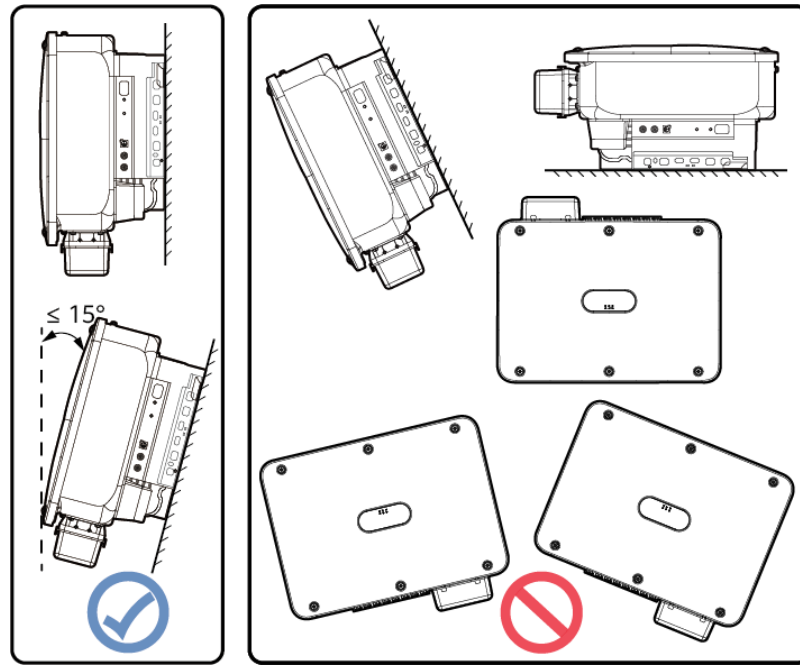





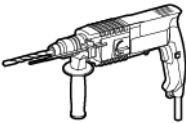

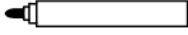
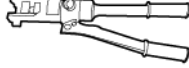

- Install the inverter vertically or at a maximum back tilt of 15 degrees to facilitate heat dissipation.
- Do not install the inverter at forward tilted, excessive backward tilted, side tilted, horizontal, or upside down positions.

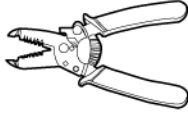
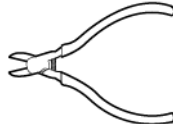

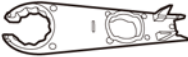

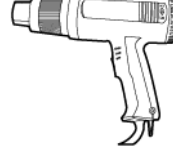
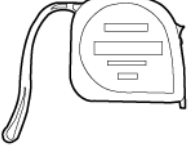

Figure 4-9 Installation angle

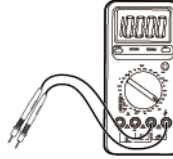

4.3 Tools

Category	Tools and Instruments		
Installation	 <p>Insulated torque socket wrench (including an extension bar)</p>	 <p>Insulated torque socket wrench (including an extension socket)</p>	 <p>Phillips insulated torque screwdriver</p>
	 <p>Hammer drill</p>	 <p>Hammer drill bit</p>	 <p>Rubber mallet</p>

Category	Tools and Instruments		
	 Utility knife	 Marker	 Hydraulic pliers
	 Cable cutter	 Wire stripper	 Diagonal pliers
	 Crimping tool H4TC0003 (Amphenol)	 Open-end wrench H4TW0001 (Amphenol)	 Heat shrink tubing
	 Crimping tool (model: PV-CZM-22100)	 Open-end wrench (model: PV-MS-HZ or PV-MS)	 Heat gun
	 Steel measuring tape	 Level	 Multimeter DC voltage measurement range ≥ 1100 V DC

Category	Tools and Instruments		
	 Cable tie	 Vacuum cleaner	-
Personal protective equipment (PPE)	 Goggles	 Protective shoes	 Dust mask
	 Protective gloves	 Insulated gloves	-

4.4 Checking Before Installation

Outer Packing Materials

Before unpacking the inverter, check the outer packing materials for damage, such as holes and cracks, and check the inverter model. If any damage is found or the inverter model is not what you requested, do not unpack the package and contact your supplier as soon as possible.

NOTE

You are advised to remove the packing materials within 24 hours before installing the inverter.

Package Contents

NOTICE

- After placing the equipment in the installation position, unpack it with care to prevent scratches. Keep the equipment stable during unpacking.

After unpacking the inverter, check that the contents are intact and complete. If any damage is found or any component is missing, contact your supplier.

 **NOTE**

For details about the number of contents, see the *Packing List* in the packing case.

4.5 Moving the Inverter

Procedure

Step 1 Take the inverter out of the packing case and move it to the installation position.

NOTICE

- After placing the equipment in the installation position, unpack it with care to prevent scratches. Keep the equipment stable during unpacking.
 - Move the inverter with care to prevent device damage and personal injury.
 - Do not use the wiring terminals and ports at the bottom to support any weight of the inverter.
 - When you need to temporarily place the inverter on the ground, use foam, cardboard, or other protection material to prevent damage to its enclosure.
-

Figure 4-10 Moving the inverter

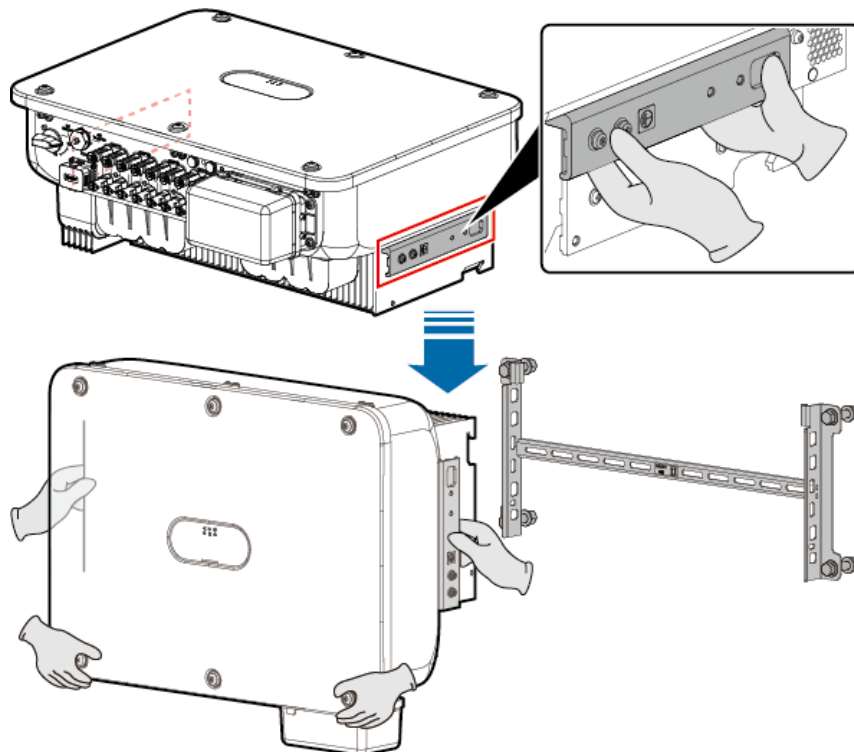

----End

4.6 Installing the Inverter on a Wall

Procedure

Step 1 Determine the hole positions and mark them using a marker.

Step 2 Secure the mounting bracket.

⚠ DANGER

Avoid drilling holes into the water pipes or power cables buried in the wall.

Figure 4-11 Expansion bolt structure

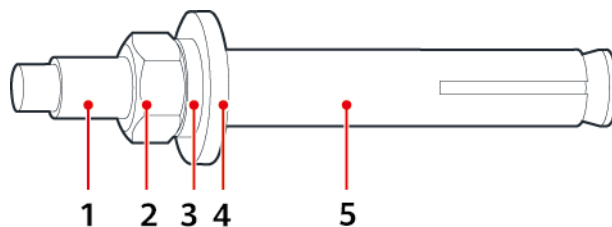

IS05W00018

- | | | |
|-----------------|----------------------|-------------------|
| (1) Bolt | (2) Nut | (3) Spring washer |
| (4) Flat washer | (5) Expansion sleeve | |

NOTICE

- To prevent dust inhalation or contact with eyes, wear safety goggles and a dust mask when drilling holes.
 - Use a vacuum cleaner to clean up dust in and around the holes, and measure the spacing. If the holes are inaccurately positioned, drill the holes again.
 - Level the top of the expansion sleeve with the concrete wall after removing the nut, spring washer, and flat washer. Otherwise, the mounting bracket will not be securely installed on the concrete wall.
-

Figure 4-12 Installing expansion bolts

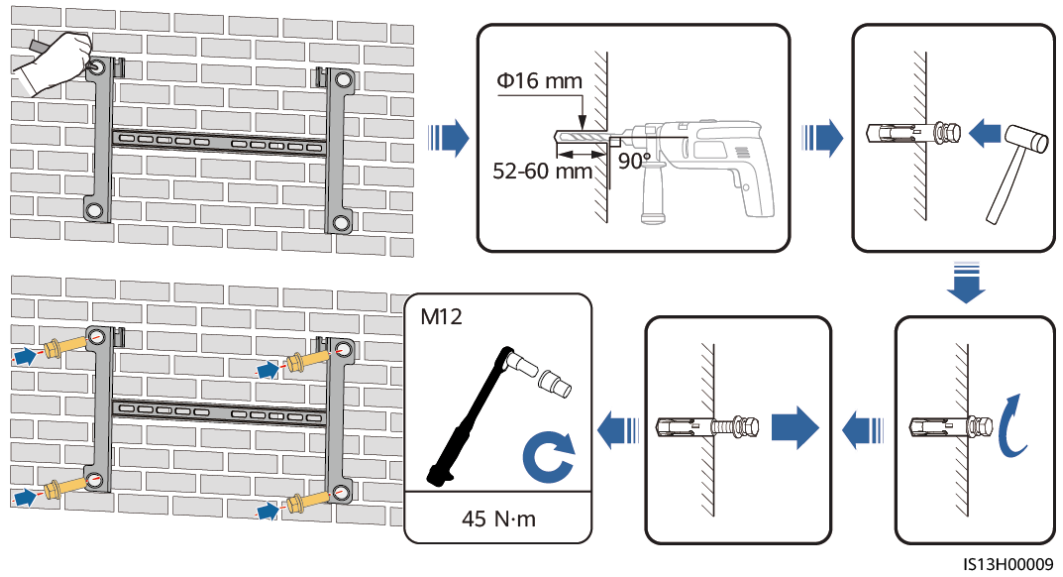

Step 3 Install the inverter on the mounting bracket.

Figure 4-13 Installing the inverter

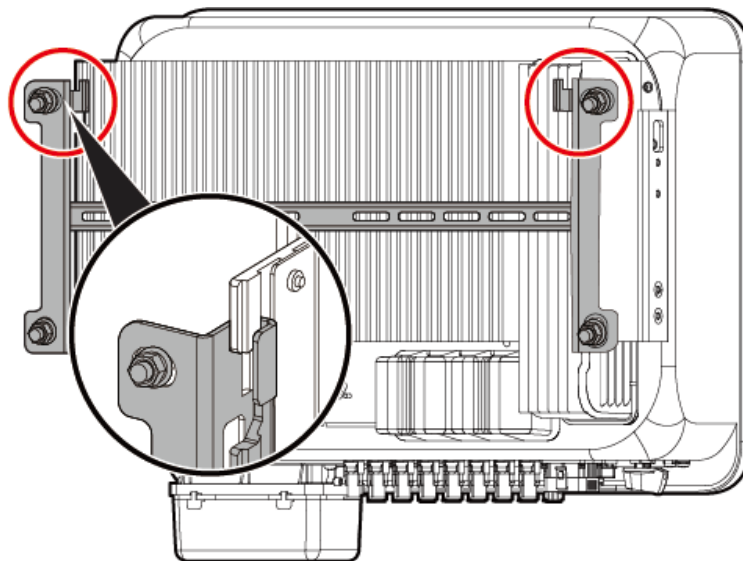

Step 4 Tighten the screws on both sides of the inverter.

Figure 4-14 Tightening the screws

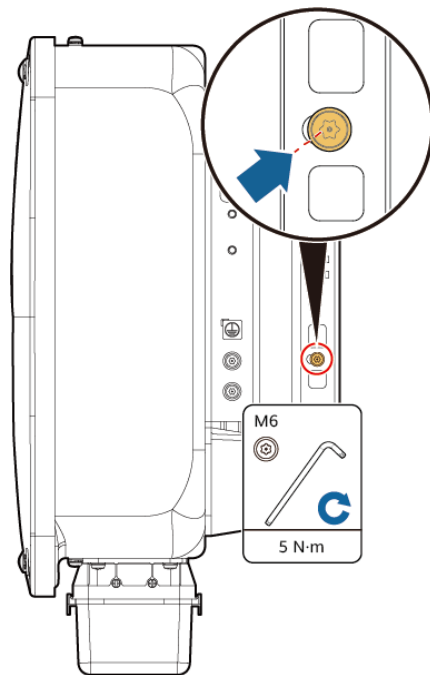

NOTICE

Tighten the screws on the sides before connecting cables.

----End

4.7 Installing the Inverter on a Support

Procedure

Step 1 Secure the mounting bracket.

Figure 4-15 Securing the mounting bracket

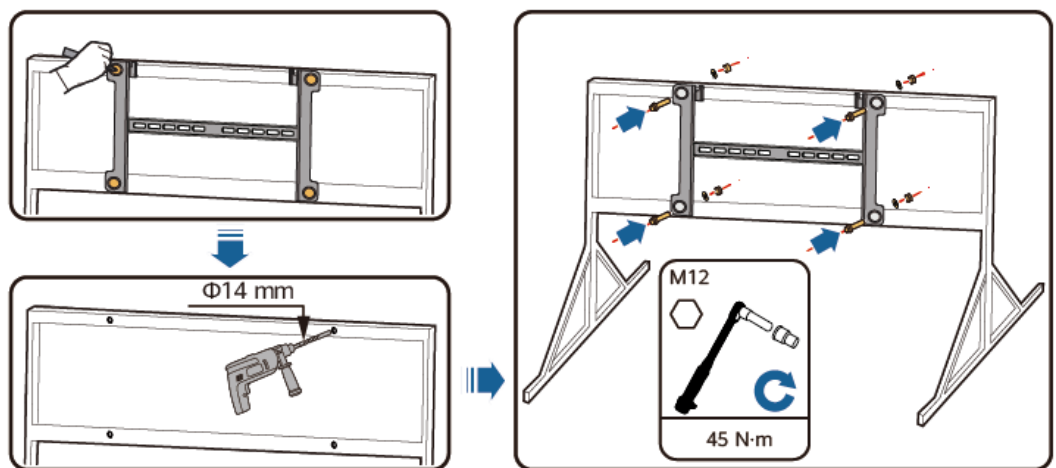

IS13H00008

 NOTE

You are advised to apply anti-rust paint on the hole positions for protection.

Step 2 Install the inverter on the mounting bracket.

Figure 4-16 Installing the inverter

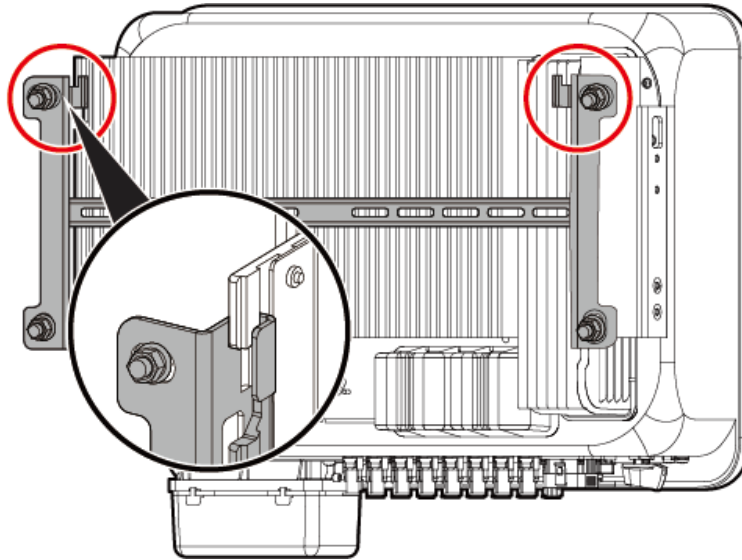

Step 3 Tighten the nuts on both sides of the inverter.

Figure 4-17 Tightening nuts

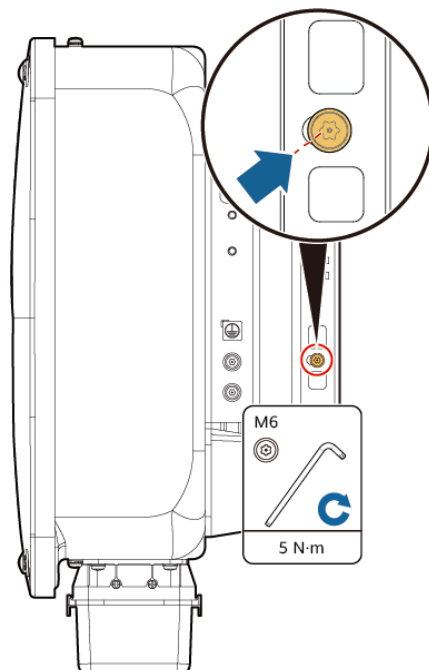

NOTICE

Tighten the screws on the sides before connecting cables.

----**End**

5 Electrical Connections

5.1 Precautions

 **DANGER**

When exposed to sunlight, the PV arrays supply DC voltage to the inverter. Before connecting cables, ensure that all **DC SWITCH** on the inverter are OFF. Otherwise, the high voltage of the inverter may result in electric shocks.

 **DANGER**

- The site must be equipped with qualified fire fighting facilities, such as fire sand and carbon dioxide fire extinguishers.
 - Wear personal protective equipment and use dedicated insulated tools to avoid electric shocks or short circuits.
-

 **WARNING**

- The equipment damage caused by incorrect cable connections is beyond the warranty scope.
 - Only certified electrician can perform electrical terminations.
 - Operation personnel must wear PPE when connecting cables.
 - Before connecting cables to ports, leave enough slack to reduce the tension on the cables and prevent poor cable connections.
-

CAUTION

- Stay away from the equipment when preparing cables to prevent cable scraps from entering the equipment. Cable scraps may cause sparks and result in personal injury and equipment damage.

NOTE

The cable colors shown in the electrical connection diagrams provided in this section are for reference only. Select cables in accordance with local cable specifications (green-and-yellow cables are only used for protective earthing).

5.2 Preparing Cables

Figure 5-1 SUN2000 cable connections (the components in dashed boxes are optional)

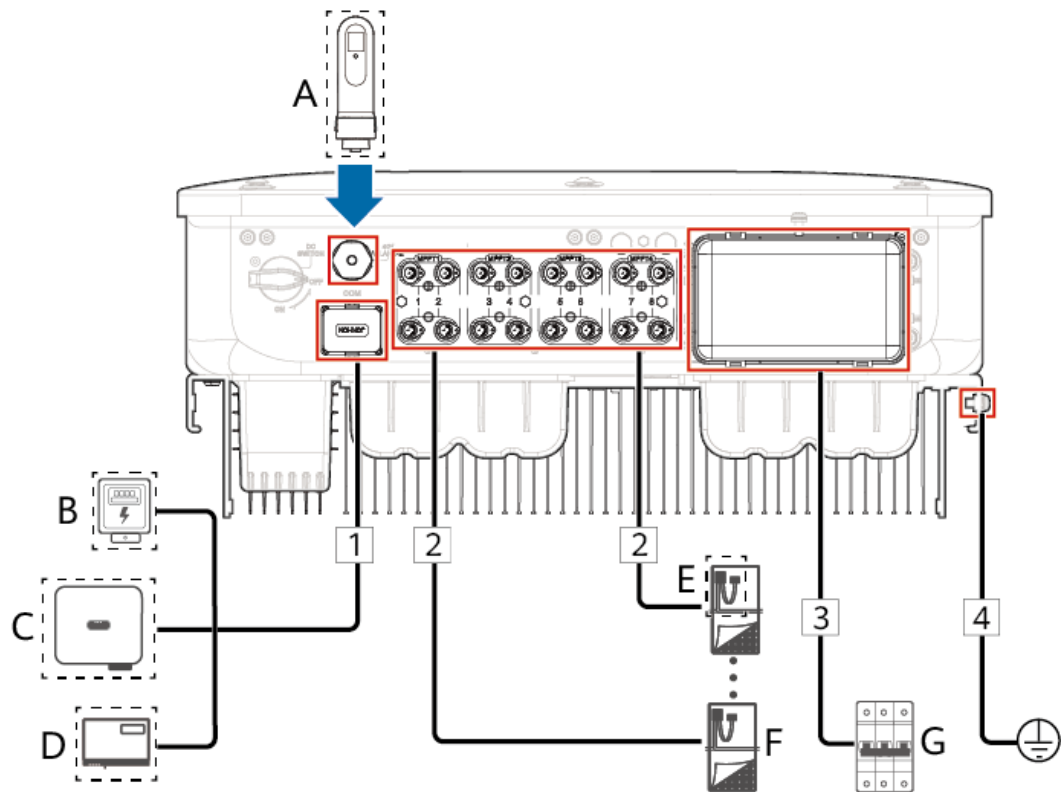

Table 5-1 Component description

No.	Component	Description	Source
A	Smart Dongle ^[1]	The SUN2000 system communicates with the management system through the Smart Dongle.	Purchased from the Company

No.	Component	Description	Source
B	Power meter ^[2]	Supported meter models: DTSU666-H, DTSU666-HW, YDS60-80, YDS60-C24, DTSU71, DHSU1079-CT, DHSU1079-ZT, and DTSU71C	Purchased from the Company
C	SUN2000	Select a proper model as required.	Purchased from the Company
D	SmartLogger	The SUN2000 communicates with the management system through the SmartLogger.	Purchased from the Company
E	Smart PV Optimizer ^[3]	MERC-1300W-P, MERC-1100W-P	Purchased from the Company
F	PV string	<ul style="list-style-type: none"> • A PV string consists of PV modules connected in series. • The inverter supports eight PV string inputs. 	Prepared by the customer
G	AC switch	<p>To ensure that the inverter can be safely disconnected from the power grid when an exception occurs, connect an AC switch to the AC side of the inverter. Select an appropriate AC switch in accordance with local industry standards and regulations. The Company recommends the following switch specifications:</p> <p>Three-phase AC circuit breaker with a rated voltage greater than or equal to 500 V AC and a rated current of:</p> <ul style="list-style-type: none"> • 63 A (SUN2000-30K) • 100 A (SUN2000-40K) 	Prepared by the customer

No.	Component	Description	Source
<p>Note [1]: For details about how to operate a WLAN-FE Smart Dongle, see SDongleA-05 Smart Dongle Quick Guide (WLAN-FE). For details about how to operate a 4G Smart Dongle, see SDongleB-06 Smart Dongle Quick Guide (4G).</p> <p>Note [2]: For details about how to operate a power meter, see the DTSU666-H 100 A and 250 A Smart Power Sensor User Manual, DTSU666-HW Smart Power Sensor Quick Guide, YDS60-80 Smart Power Sensor Quick Guide, YDS60-C24 Smart Power Sensor Quick Guide, DTSU71 Smart Power Sensor Quick Guide, DHSU1079-CT Smart Power Sensor Quick Guide, and DHSU1079-ZT Smart Power Sensor Quick Guide. DTSU71C Smart Power Sensor Quick Guide.</p> <p>Note [3]: For details about optimizer operations, see MERC-(1300W, 1100W)-P Smart PV Optimizer User Manual. For details about setting the physical layout of optimizers, see E Setting the Physical Layout of Smart PV Optimizers.</p>			

NOTICE

- Cable specifications must meet the requirements in local standards. Device damage caused by using cables with incorrect specifications will not be covered by the warranty.
- If the inverter is used with an optimizer, route AC and DC power cables separately to prevent AC power cables from interfering with optimizer communication.

Table 5-2 Cable description

No.	Name	Type	Conductor Cross-Sectional Area	Cable Outer Diameter	Source
1	(Optional) Signal cable	Outdoor shielded twisted pair cable (recommended model: DJYP2VP2-2x2x0.75)	0.2–1 mm ²	4–11 mm	Prepared by the customer
2	DC input power cable	PV cable that meets the 1100 V standard	4–6 mm ²	4.5–7.8 mm	Prepared by the customer

No.	Name	Type	Conductor Cross-Sectional Area	Cable Outer Diameter	Source
3	AC output power cable	Outdoor copper/aluminum cable	16–50 mm ² outdoor copper cable ^a 35–50 mm ² outdoor aluminum cable ^a	16–38 mm	Prepared by the customer
4	PE cable	Single-core outdoor copper cable	≥ 16 mm ²	-	Prepared by the customer

Note a: Five-core cables with a cross-sectional area of 5 x 35 mm² or 5 x 50 mm² are not supported.

 NOTE

The factors to be considered in cable selection include the rated current, cable type, routing mode, ambient temperature, and maximum acceptable line loss.

5.3 Connecting a PE Cable

Precautions

 **DANGER**

- Ensure that the PE cable is securely connected. Otherwise, electric shocks may occur.
- Do not connect the neutral wire to the enclosure as a PE cable. Otherwise, electric shocks may occur.

 NOTE

- The PE point at the AC output port is used only as a PE equipotential bonding point, and cannot substitute for the PE point on the enclosure.
- It is recommended that silicone grease or paint be applied around the ground terminal after the PE cable is connected.
- You can enable or disable phase-to-ground short-circuit protection on the app (choose **Set > Feature parameters > Grounding abnormal shutdown**) to address the situation in which a phase wire is short-circuited to PE. If this function is disabled, the inverter detects the alarm and can connect to the power grid and generate power normally.

Procedure

Step 1 Crimp an OT terminal.

For details about the OT terminal requirements and preparation method, see [Crimping an OT Terminal](#).

Step 2 Connect the PE cable.

Figure 5-2 Connecting a PE cable

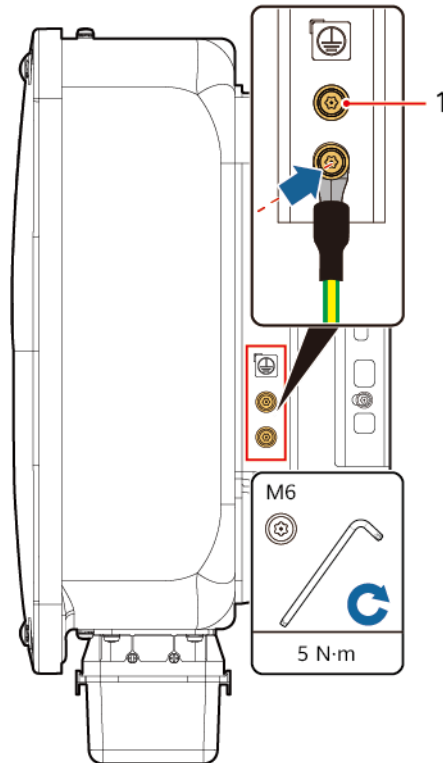

(1) Standby PE point

----End

5.4 Connecting an AC Output Power Cable

Precautions

- An AC switch shall be installed on the AC side of the inverter. To ensure that the inverter can safely disconnect itself from the power grid when an exception occurs, select a proper overcurrent protection device in compliance with local power distribution regulations.
- The inverter is installed with an integrated residual current monitoring unit. When the inverter detects that residual current exceeds the permitted value, it disconnects from the power grid quickly.

 **WARNING**

- Do not connect loads between an inverter and an AC switch that directly connects to the inverter. Otherwise, the switch may trip by mistake.
 - If an AC switch is used with specifications beyond local standards, regulations, or the Company's recommendations, the switch may fail to turn off in a timely manner in case of exceptions, causing serious faults.
-

 **CAUTION**

- Each inverter shall be equipped with an AC output switch. Multiple inverters shall not connect to the same AC switch.
 - Cables must be vertically routed into the maintenance compartment, PV terminals, and other wiring terminals to avoid damage caused by horizontal stress on the terminals, which is not covered under the warranty.
-

NOTICE

- If the external AC switch provides the leakage protection function, the rated residual operating current must be greater than or equal to 300 mA.
 - If multiple inverters are connected to the master leakage protection device through their external AC switches, the rated residual operating current of the device must be greater than or equal to the number of inverters x 300 mA.
 - Use a socket wrench and extension rod to connect the AC power cable. The extension rod must be longer than 100 mm.
 - Reserve sufficient slack for the PE wire to ensure that the PE wire is the last cable bearing the force when the AC output power cable is subject to a pulling force due to force majeure.
 - Do not install third-party devices in the AC connection box.
-

Prerequisites

You need to prepare M8 OT/DT terminals by yourself.

For details about the OT/DT terminal requirements and preparation method, see [Crimping an OT/DT Terminal](#).

Figure 5-3 Wiring ports

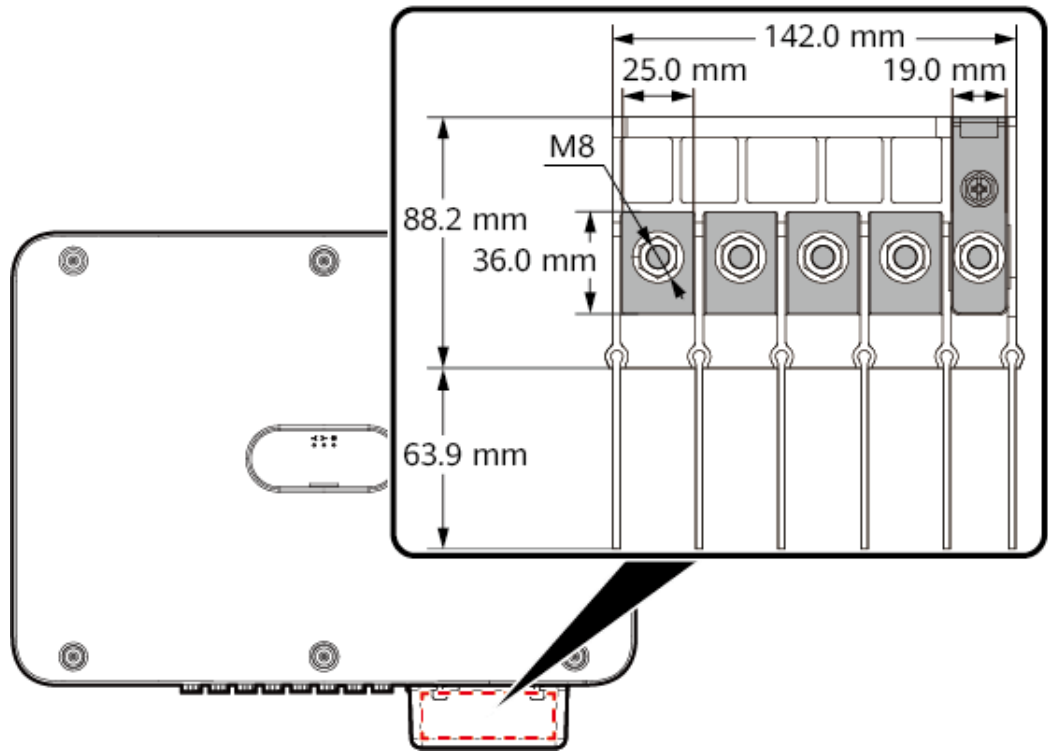
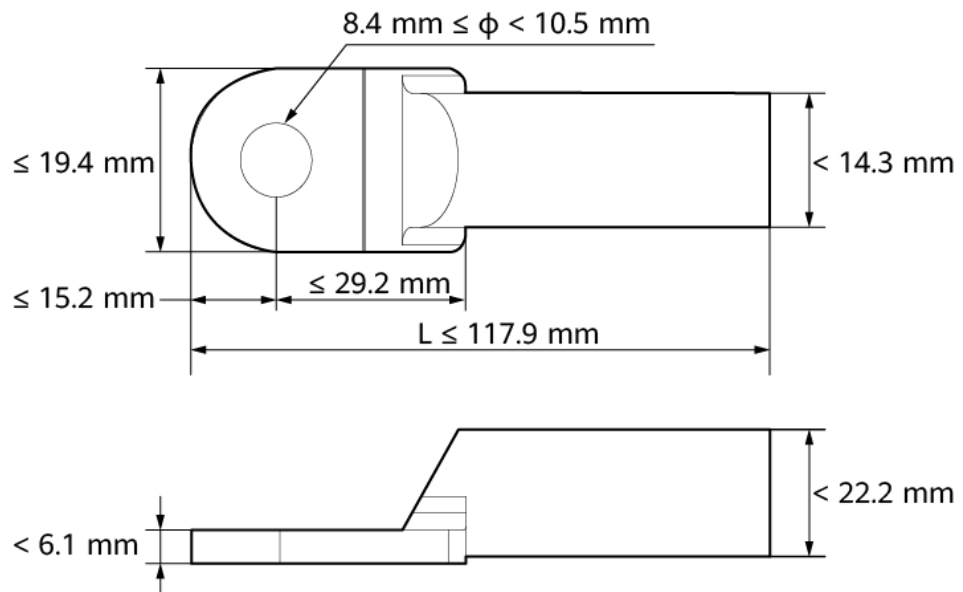

Figure 5-4 Specifications of the crimped OT/DT terminal



Procedure

Step 1 Remove the AC terminal box and install partition boards.

NOTICE

To remove the AC terminal box, do as follows:

Method 1: Press the two buckles at the front of the AC terminal box respectively with both thumbs. Rotate the AC terminal box counterclockwise and remove it.

Method 2: Press either of the buckles at the front of the AC terminal box with your thumbs, and then press the other buckle. Rotate the box counterclockwise and remove it.

Figure 5-5 Removing the AC terminal box

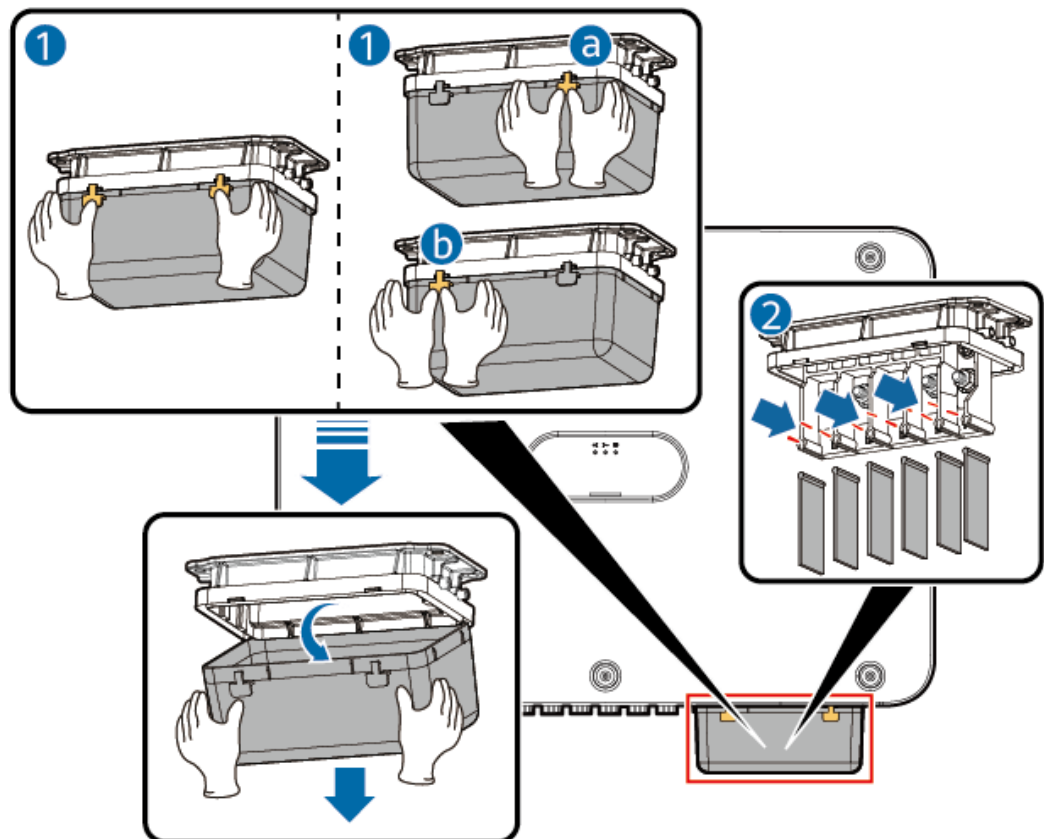

Step 2 Connect the AC output power cable.

NOTE

- Do not route a cable with a crimped OT terminal directly through the rubber liner. Otherwise, the liner may be damaged.
- Reserve sufficient slack for the PE wire to ensure that the PE wire is the last cable bearing the force when the AC output power cable is subject to a pulling force due to force majeure. It is recommended that the stripping length of the PE cable be 15 mm longer than that of other cables.
- The cable colors shown in the figures are for reference only. Select an appropriate cable according to the local standards.

Figure 5-6 Stripping requirements (using a five-core cable as an example)

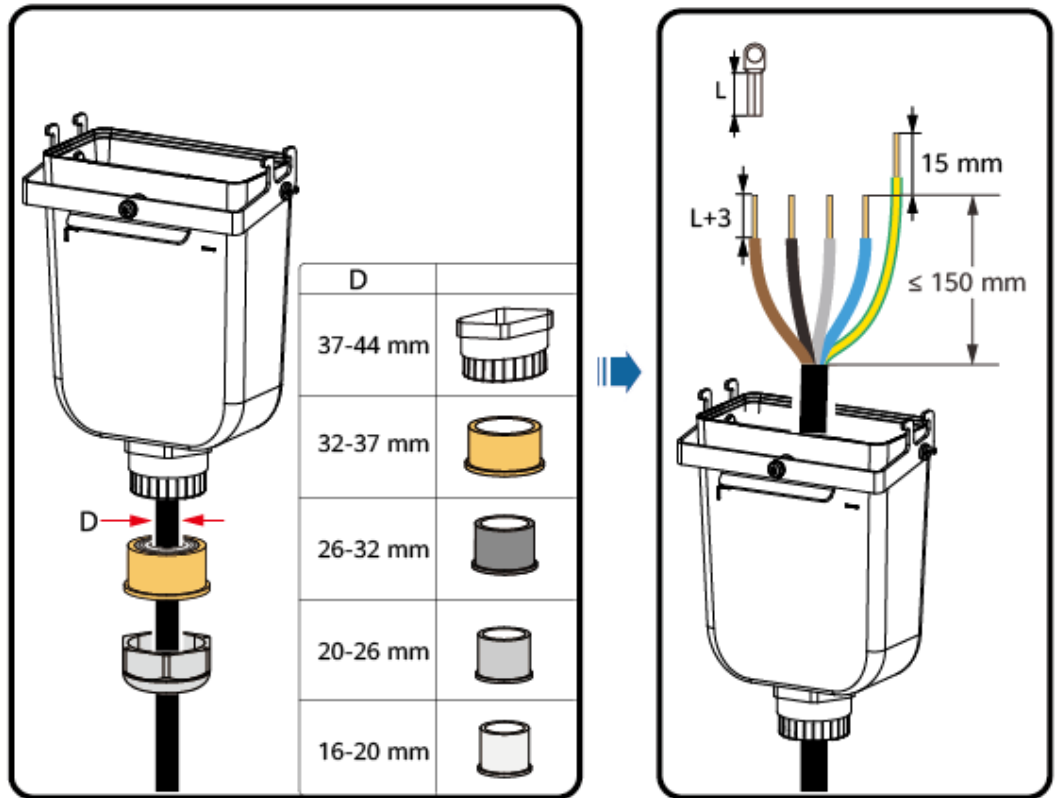

Figure 5-7 Five-core cable (L1, L2, L3, N, and PE)

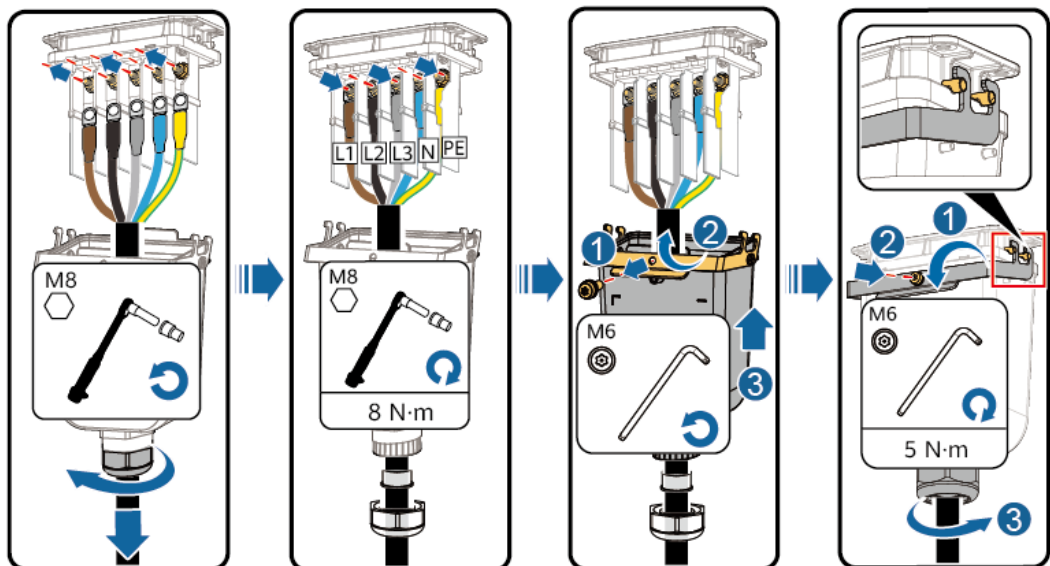

Figure 5-8 Four-core cable (L1, L2, L3, and PE)

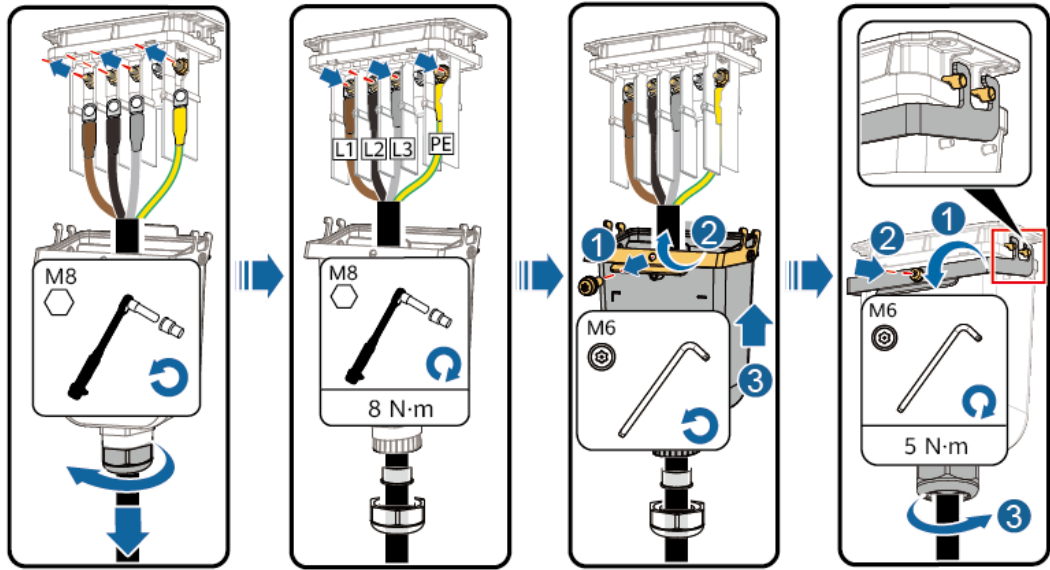

Figure 5-9 Four-core cable (L1, L2, L3, and N)

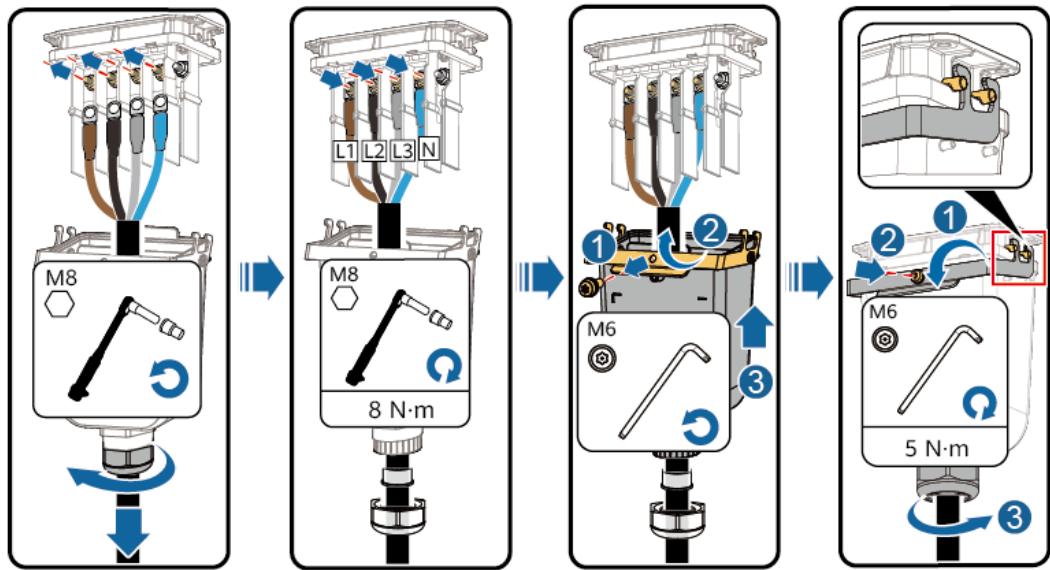

Figure 5-10 Three-core cable (L1, L2, and L3)

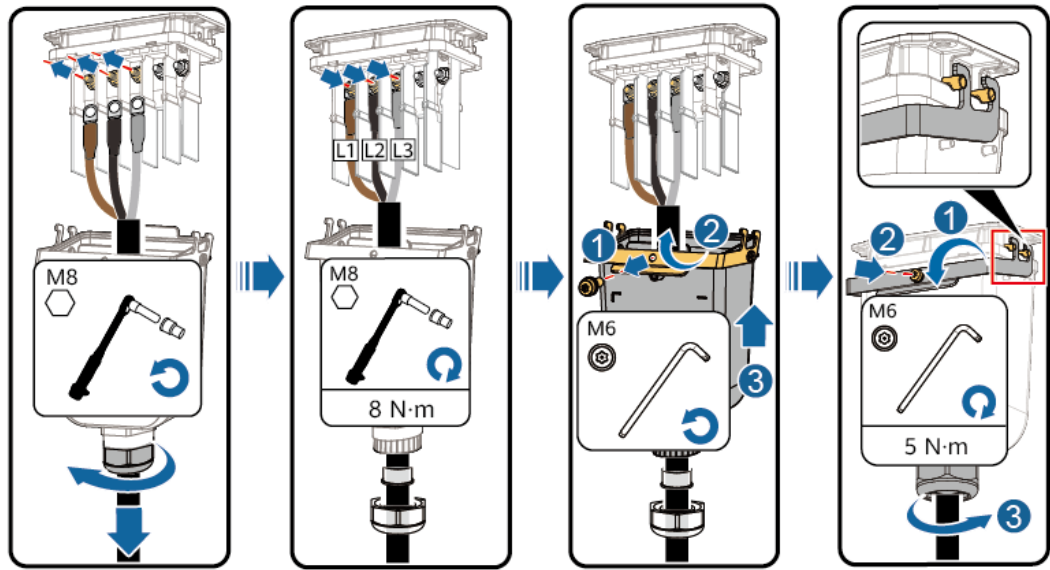
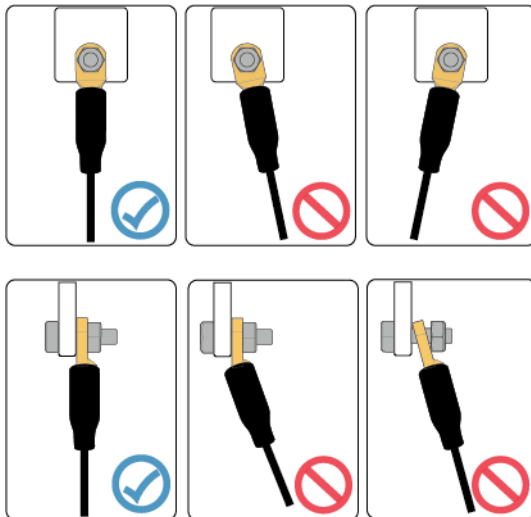

Figure 5-11 Wiring requirements



----End

5.5 Connecting DC Input Power Cables

5.5.1 Cable Connection Description

Precautions

 DANGER

- Before connecting the DC input power cables, ensure that the DC voltage is within the safe range (lower than 60 V DC) and that the **DC SWITCH** on the inverter is **OFF**. Failing to do so may result in electric shocks.
 - When the inverter is operating, do not perform maintenance or operations on the DC input power cables, such as connecting or disconnecting a PV string or a PV module in the PV string. Otherwise, electric shocks may occur.
 - If no PV string connects to a DC input terminal of the inverter, do not remove the waterproof cap from the DC input terminal. Otherwise, the protection level of the inverter will decrease.
-

 WARNING

Ensure that the following conditions are met. Otherwise, the inverter may be damaged or even a fire may occur.

- PV modules connected in series in each PV string are of the same specifications.
 - The DC input voltage of each PV string must be lower than or equal to 1100 V DC under any circumstances.
 - The maximum short-circuit current of each PV string must be lower than or equal to 40 A under any circumstances.
 - The polarities of electric connections must be correct on the DC input side. The positive and negative terminals of a PV string must be connected to corresponding positive and negative DC input terminals of the inverter.
 - If a DC input power cable is connected in reverse polarity, do not immediately operate on the **DC SWITCH** or positive and negative connectors. Wait until the night when solar irradiance declines and the PV string current drops to below 0.5 A. Then set the **DC SWITCH** to **OFF**, remove the positive and negative connectors, and correct the polarities of the DC input power cable.
-

 WARNING

During the installation of PV strings and the inverter, the positive or negative terminals of PV strings may be short-circuited to the ground if the power cables are not properly installed or routed. In this case, an AC or DC short circuit may occur and damage the inverter. The resulting device damage is not covered by the product warranty.

CAUTION

Take waterproof and insulation measures for unused DC power cables to avoid personal injury or property loss caused by accidental contact with high voltage or other reasons.

NOTICE

- The inverter does not support power supplies other than PV strings. The output of the PV string connected to the inverter cannot be grounded. Ensure that the PV module output is well insulated to ground.
- The PV strings connected to the same MPPT circuit shall contain the same number and model of PV modules or optimizers.
- Use the PV connectors delivered with the inverter.
- To maximize energy yield, the voltage difference between MPPTs shall be less than 85 V if no optimizer is configured. If optimizers are configured, refer to the optimizer user manual.

Terminal Description

Figure 5-12 DC input terminals

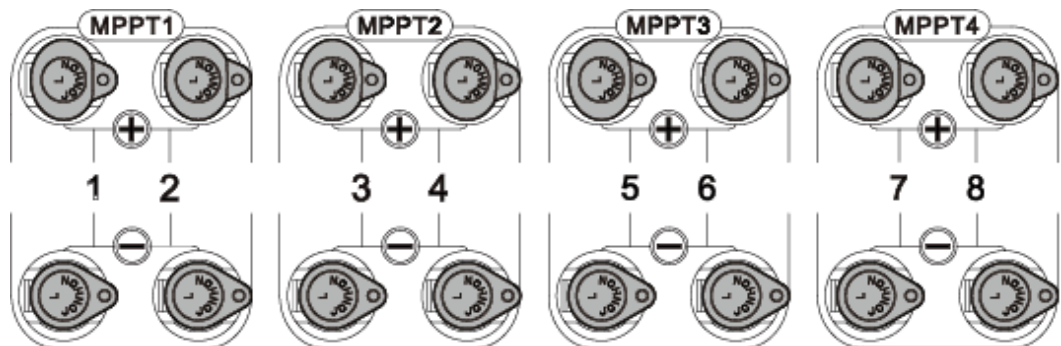

NOTE

If not all DC input terminals need to be connected, the terminal selection must meet the following requirements:

1. Evenly distribute the DC input power cables on the four MPPTs and preferentially connect them in the order from MPPT 1 to MPPT 4.
2. Maximize the number of connected MPPT circuits.

Number of PV Strings	Terminal Selection	Number of PV Strings	Terminal Selection
1	PV1	2	PV1, PV7
3	PV1, PV3, PV7	4	PV1, PV3, PV5, PV7

Number of PV Strings	Terminal Selection	Number of PV Strings	Terminal Selection
5	PV1, PV2, PV3, PV5, PV7	6	PV1, PV2, PV3, PV5, PV7, PV8
7	PV1, PV2, PV3, PV4, PV5, PV7, PV8	8	PV1, PV2, PV3, PV4, PV5, PV6, PV7, PV8

5.5.2 Measuring the Insulation Resistance of PV Strings to the Ground

NOTICE

In a PV system, the insulation resistance of a PV string reflects the insulation status between the PV string and the ground. A low insulation resistance indicates poor insulation performance, which may cause personal safety and inverter performance problems. Therefore, before connecting PV strings to the inverter, measure the insulation resistance of each PV string to the ground and check that the insulation resistance is normal to ensure normal operation of the inverter.

5.5.2.1 Optimizers Configured

Prerequisites

Set a multimeter to the DC position and use it to measure the voltage between the positive and negative terminals of a PV string. If the voltage is a negative value, the positive and negative terminals are connected in reverse polarity. Rectify the connection.

Procedure

- Step 1** Connect the positive and negative output connectors of a PV string to a branch cable, and use an insulation resistance tester to measure the insulation resistance of the PV string cable to the ground: Add a maximum of 1500 V DC voltage between the cable and the ground, and check the insulation resistance.

Figure 5-13 Measuring the insulation resistance of each PV string

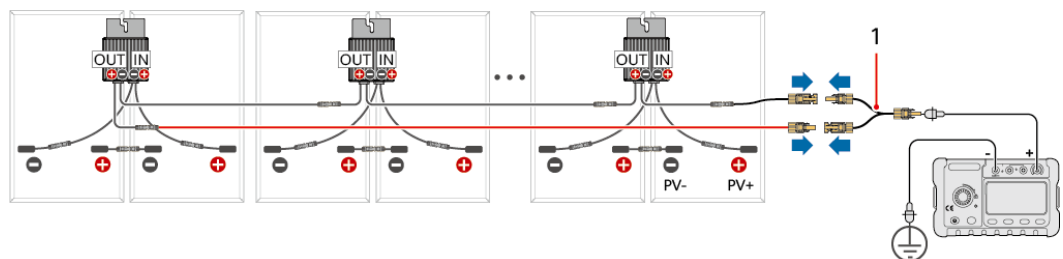
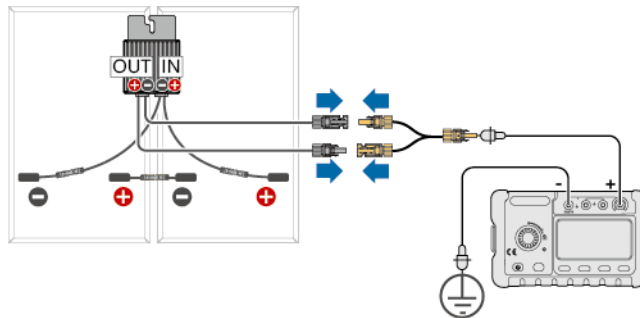

Figure 5-15 Measuring the insulation resistance of a PV module and the paired optimizer



If...	Then...
Insulation resistance $\geq 1 \text{ M}\Omega$	If the disconnected optimizer and PV module are normal, perform Step 3 for another PV module and the paired optimizer.
Insulation resistance $< 1 \text{ M}\Omega$	The optimizer, PV module, or both are faulty. Go to Step 4 for troubleshooting.

Step 4 Check whether the PV module or optimizer is faulty by measuring each component separately:

1. Disconnect the PV module from the optimizer.
2. Connect the positive and negative output connectors of the optimizer to a branch cable, and then connect the cable to the positive probe of the insulation resistance tester. Connect the negative probe of the insulation resistance tester to the ground. Measure the insulation resistance of the optimizer to the ground.

Figure 5-16 Measuring the insulation resistance of an optimizer

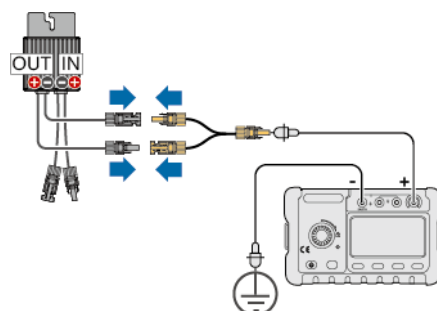

If...	Then...
Insulation resistance $\geq 1 \text{ M}\Omega$	The optimizer is normal, but the PV module is faulty.

If...	Then...
Insulation resistance < 1 MΩ	The optimizer is faulty. After replacing the optimizer, check whether the PV module is also faulty.

3. Measure the insulation resistance of the PV module. You are advised to consult the PV module manufacturer to determine whether the PV module is abnormal.

 **NOTE**

For a PV module without an optimizer, you do not need to use a branch cable to connect PV+ and PV-. Instead, measure the insulation resistance at the positive and negative terminals of the PV module separately.

4. Replace the faulty PV module or optimizer.

----End

5.5.2.2 Optimizers Not Configured

Prerequisites

The voltage between the positive and negative terminals of a PV string is normal.

Set a multimeter to the DC position (measurement range ≥ 1100 V) and use it to measure the voltage between the positive and negative terminals of a PV string.

If...	Then...
Voltage < 0	The positive and negative terminals are connected in reverse polarity. Rectify the connection.
Voltage > 1100 V	There are too many PV modules, which may result in inverter damage. Do not connect the inverter.

Procedure

- Step 1** Use an insulation resistance tester to measure the insulation resistance of a PV-cable to the ground. Add a maximum of 1500 V DC voltage between the cable and the ground, and check the insulation resistance.

Figure 5-17 Measuring the insulation resistance of PV- for each PV string

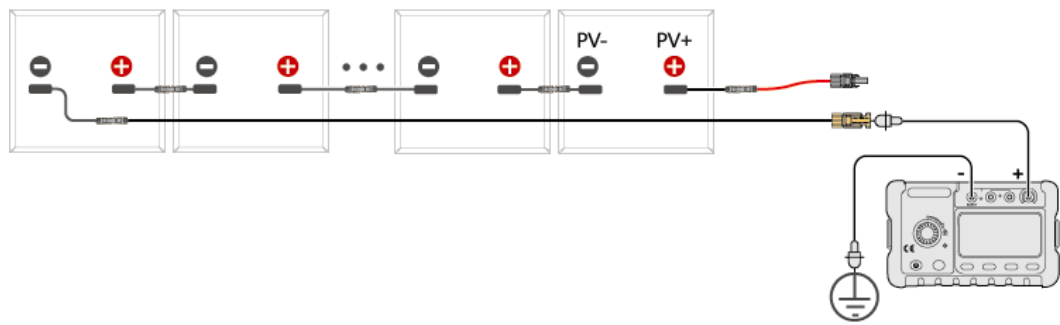

If...	Then...
Insulation resistance $\geq 1 \text{ M}\Omega$	This is normal.
Insulation resistance $< 1 \text{ M}\Omega$	You need to check the insulation of the cable or PV string. Go to Step 2 .

NOTE

You can prepare a tool to connect all PV- cables together using a conversion adapter and measure the ground insulation resistance of all PV- cables of an inverter at a time.

Figure 5-18 Measuring the insulation resistance of PV- for all PV strings

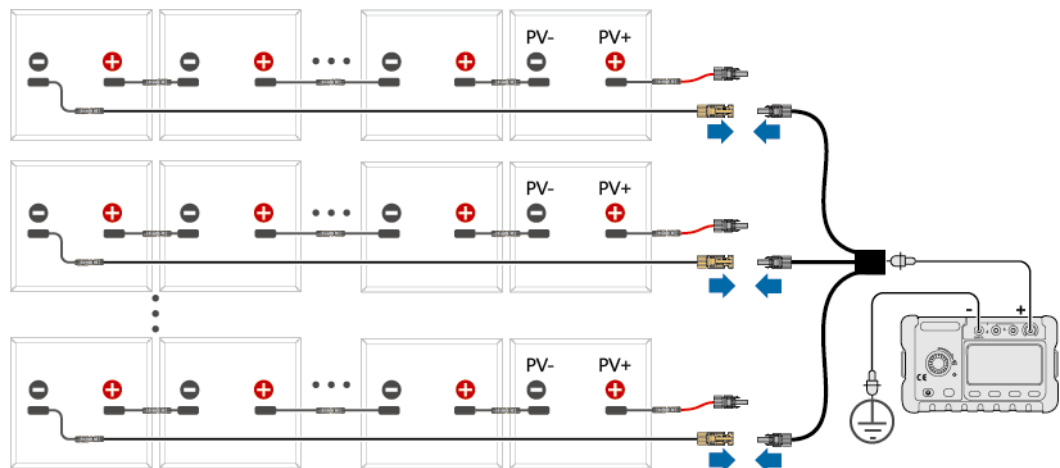

If...	Then...
Insulation resistance $\geq 1 \text{ M}\Omega$	This is normal.
Insulation resistance $< 1 \text{ M}\Omega$	You need to check the insulation of the cables or PV strings.

Step 2 Disconnect the extension cable from the PV string. Connect the extension cable to the branch cable and use an insulation resistance tester to measure the insulation

resistance of the extension cable to the ground. Add a maximum of 1500 V DC voltage between the cable and the ground, and check the insulation resistance.

Figure 5-19 Measuring the insulation resistance of the extension cable

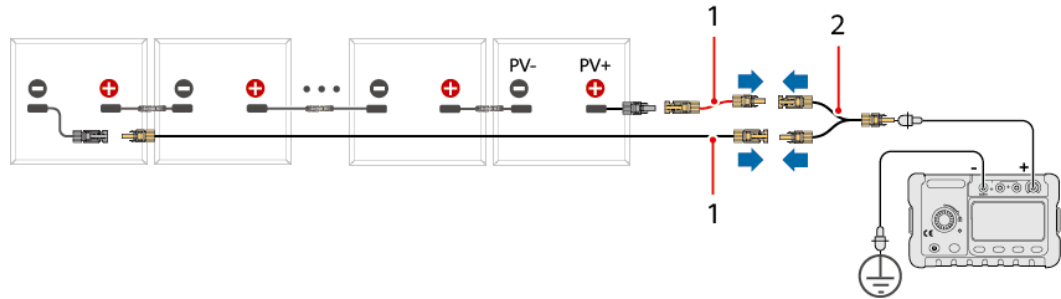

(1) Extension cable

(2) Branch cable

If...	Then...
Insulation resistance $\geq 1 \text{ M}\Omega$	The extension cable is normal. Go to Step 3 .
Insulation resistance $< 1 \text{ M}\Omega$	The extension cable is abnormal. Check the cable. After the check is completed, go to Step 1 to check whether the PV string is normal. If the PV string is abnormal, go to Step 3 .

Step 3 Measure the insulation resistance of the PV module. You are advised to consult the PV module manufacturer to determine whether the PV module is abnormal.

----End

5.5.3 Connecting Cables to Amphenol Helios H4 Terminals

NOTICE

- You are advised to use the H4TC0003 (Amphenol) crimping tool and do not use it with the positioning block. Otherwise, the metal terminals may be damaged.
- The H4TW0001 (Amphenol) open-end wrench is recommended.
- Cables with high rigidity, such as armored cables, are not recommended as DC input power cables, because poor contact may be caused by the bending of the cables.
- Before assembling DC connectors, label the cable polarities correctly to ensure correct cable connections.
- After the positive and negative connectors snap into place, try to pull the DC input power cables back to check that they are secure.
- Insert the crimped metal terminals of the positive and negative power cables into the appropriate positive and negative connectors. Try to pull the DC input power cables back to check that they are secure.
- If the inverter is used with optimizers, the number of optimizers in a single PV string cannot exceed 20.
- If PV strings are configured with optimizers, check the cable polarities by referring to the [MERC-\(1300W, 1100W\)-P Smart PV Optimizer Quick Guide](#).

Procedure

WARNING

- Before inserting the positive and negative connectors into the positive and negative DC input terminals of the inverter, ensure that the **DC SWITCH** is set to **OFF**.
- If a DC input power cable is reversely connected and the **DC SWITCH** is set to **ON**, do not immediately operate the **DC SWITCH** or the positive and negative connectors. Otherwise, the device may be damaged. The resulting device damage is not covered by the product warranty. Wait until the night when solar irradiance declines and the PV string current drops to below 0.5 A. Then set the **DC SWITCH** to **OFF**, remove the positive and negative connectors, and correct the polarities of the DC input power cable.

Step 1 Connect DC input power cables.

NOTICE

When installing DC input power cables, leave at least 150 mm of slack. The axial tension on PV connectors must not exceed 80 N. Radial stress or torque must not be generated on PV connectors.

Figure 5-20 DC input power cabling requirement

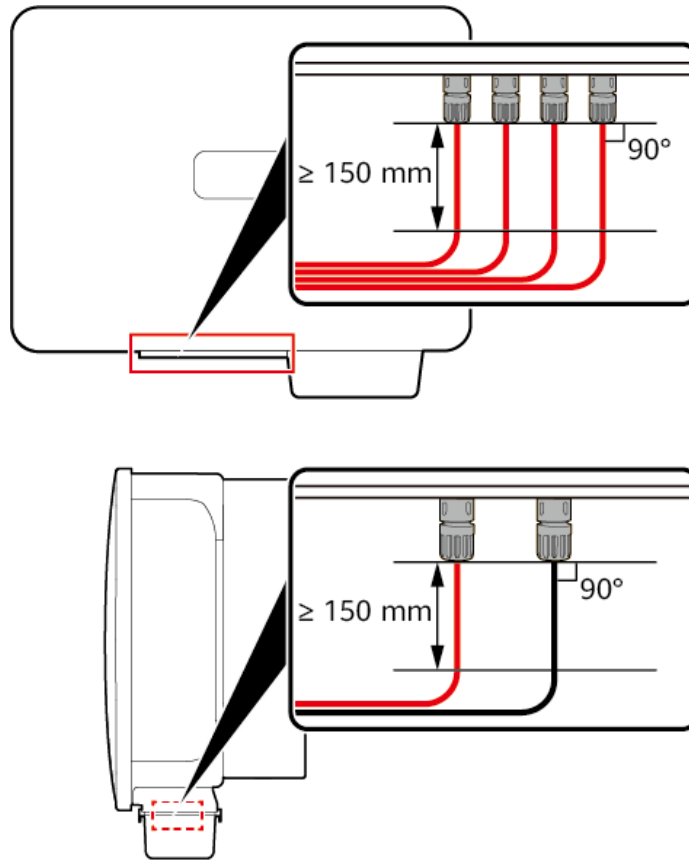

CAUTION

Use the Amphenol Helios H4 positive and negative metal terminals and DC connectors delivered with the inverter. Using incompatible positive and negative metal terminals and DC connectors may result in serious consequences. The resulting device damage is not covered by the product warranty.

NOTE

- The multimeter must have a DC voltage range of at least 1100 V. If the voltage is a negative value, the DC input polarity is incorrect. Rectify the connection. If the voltage is greater than 1100 V, too many PV modules are connected to the same string. Remove some PV modules.
- If PV strings are configured with optimizers, check the cable polarities by referring to the [MERC-\(1300W, 1100W\)-P Smart PV Optimizer Quick Guide](#).

Figure 5-21 Assembling DC connectors

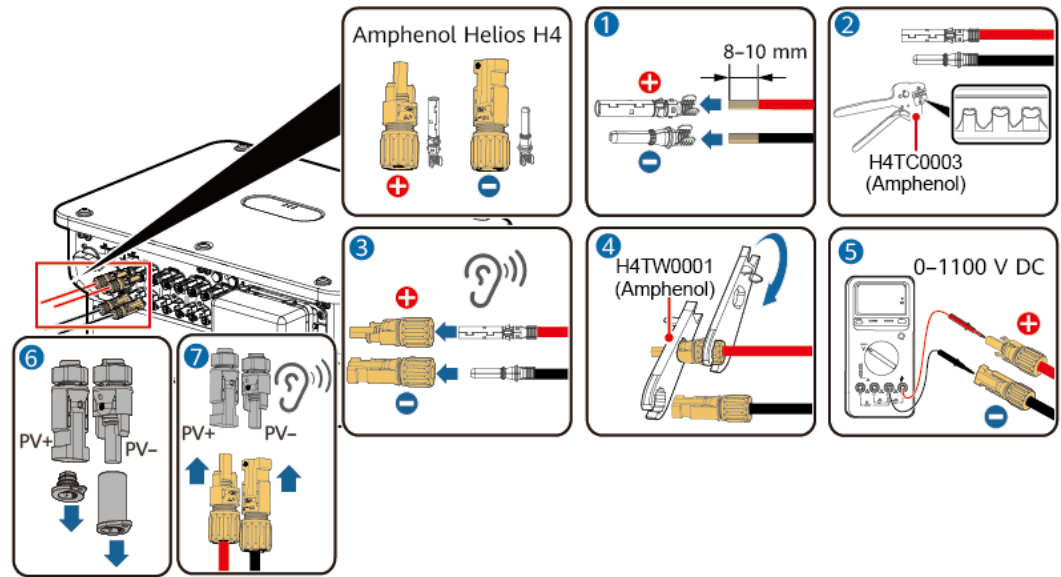

CAUTION

- Ensure that the cable cannot be pulled out after being crimped using the crimping tool, as shown by (2) in the figure.
- When you hear a click, the connectors snap into place properly, as shown by (3) and (7) in the figure. Device faults or damage caused by improper installation are not covered by the device warranty.
- Use the wrench shown by (4) in the figure to tighten the locking nut. When the wrench slips during the tightening, it indicates that the locking nut has been tightened.
- Use a multimeter to check that the cable polarity is correct, as shown by (5) in the figure.

Step 2 Use sealing plugs to seal the DC input terminals that are not connected to PV strings. Device damage caused by the absence of sealing plugs is not covered by warranty.

Figure 5-22 Sealing plugs

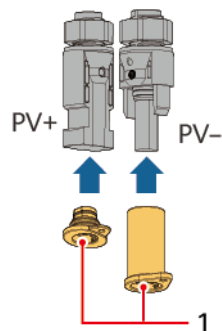

(1) Sealing plug

Table 5-3 Sealing plug models

PV+ Sealing Plug	PV- Sealing Plug
CT75A-FJB9-01	CT75A-FJB8-01
HH4SPM	HH4SPF
102-01-00064	102-01-00065
HY050-FCG-2	HY050-FCG-3

----End

Removing DC Connectors

⚠ WARNING

Before removing the positive and negative connectors, ensure that the **DC SWITCH** is set to **OFF** and that the current is less than 0.5 A.

To remove the positive and negative connectors from the inverter, insert an open-end wrench into the notch and press the wrench with an appropriate force.

Figure 5-23 Removing a DC connector

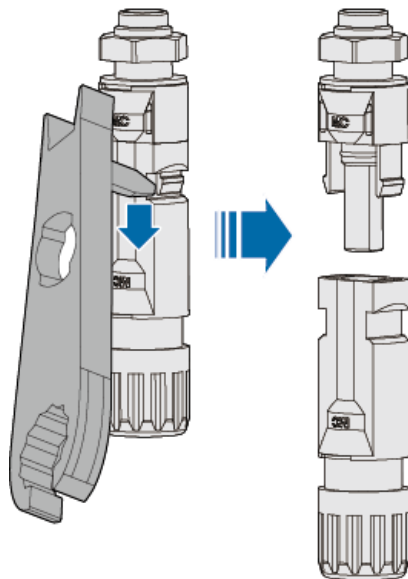

5.6 Installing the Smart Dongle

NOTE

- The Smart Dongle is not provided in standard configuration.
- In the scenario of a single inverter or multiple inverters cascaded, install one Smart Dongle or one SmartLogger. Do not use both of them at the same time.
- In the networking, the inverter where the Smart Dongle is installed is the master inverter, and other inverters are slave inverters.

5.6.1 4G Smart Dongle

Procedure

NOTICE

- If your Smart Dongle is not configured with a SIM card, you need to prepare one (dimensions: 25 mm x 15 mm; capacity: \geq 64 KB).
 - When installing the SIM card, determine its installation direction based on the silk screen and arrow on the card slot.
 - Press the SIM card in place to lock it. In this case, the SIM card is correctly installed.
 - When removing the SIM card, push it inward to eject it.
 - When reinstalling the enclosure of the Smart Dongle, ensure that the snap-fits click into place.
-

Figure 5-24 Installing the 4G Smart Dongle (SDongleB-06)

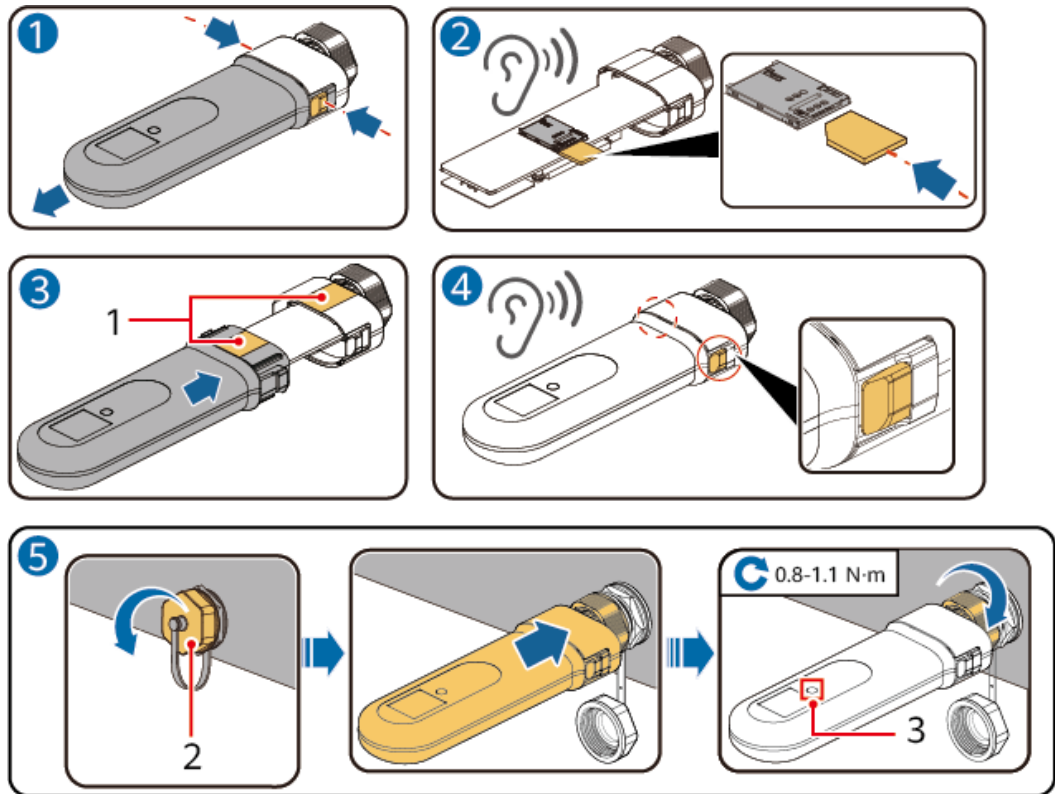

(1) Flat side

(2) Waterproof cover of the USB
port

(3) LED indicator

CAUTION

Ensure that the enclosure of the Smart Dongle is properly installed, as shown by (4) in the figure.

NOTE

- The quick guide is delivered with the Smart Dongle.
- For details about how to use the 4G Smart Dongle SDongleB-06, see [SDongleB-06 Smart Dongle Quick Guide \(4G\)](#). You can scan the QR code below to obtain the guide.



5.6.2 WLAN-FE Smart Dongle

Figure 5-25 Installing the WLAN-FE Smart Dongle (WLAN communication)

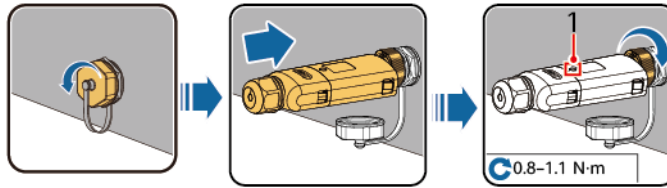

(1) LED indicator

NOTICE

Install the network cable before installing the Smart Dongle on the inverter.

Figure 5-26 Installing the WLAN-FE Smart Dongle (FE communication)

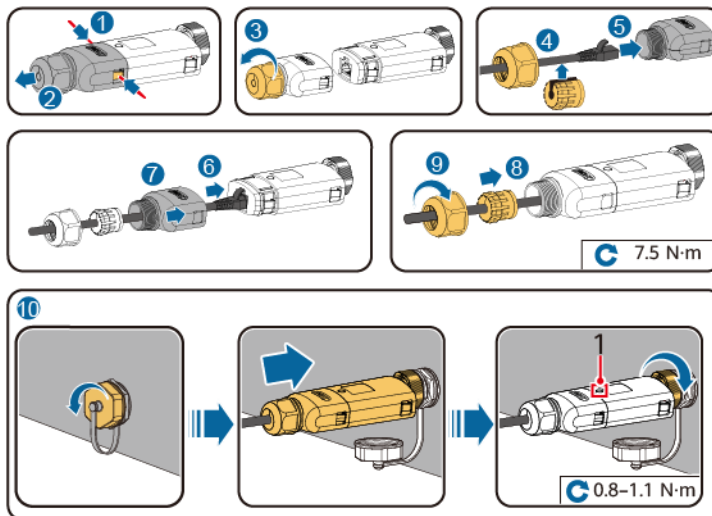

(1) LED indicator

NOTE

- The quick guide is delivered with the Smart Dongle.
- For details about how to use the WLAN-FE Smart Dongle SDongleA-05, see [SDongleA-05 Smart Dongle Quick Guide \(WLAN-FE\)](#). You can scan the QR code below to obtain the guide.



5.7 Connecting Signal Cables

5.7.1 Scenario Where Signal Cables Are Connected

NOTICE

- When laying out a signal cable, separate it from power cables and keep it away from strong interference sources to prevent communication interruption.
- Ensure that the signal cable jacket is inside the connector and surplus core wires are cut off flush with the edge of the cable jacket. Ensure that the exposed core wires are completely inserted into the holes and the cable is securely connected.
- If the Smart Dongle is configured, you are advised to install the Smart Dongle before connecting the signal cable.

Communications Port Pin Definitions

Figure 5-27 Pin definitions

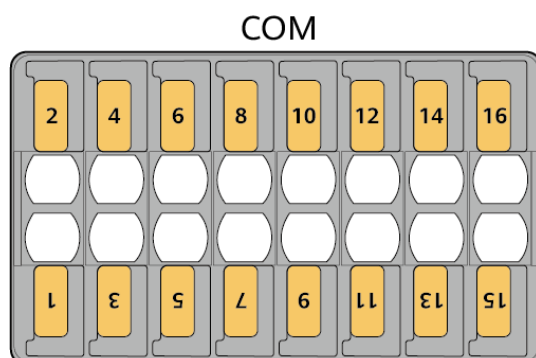

Pin	Definition	Function	Description	Pin	Definition	Function	Description
1	485A1_1	RS485 differential signal +	Used for inverter cascading or connecting to the RS485 signal port of a SmartLogger	2	485A1_2	RS485 differential signal +	Used for inverter cascading or connecting to the RS485 signal port of a SmartLogger
3	485B1_1	RS485 differential signal -		4	485B1_2	RS485 differential signal -	

Pin	Definition	Function	Description	Pin	Definition	Function	Description
5	PE	Shield layer grounding	-	6	PE	Shield layer grounding	-
7	485A2	RS485 differential signal +	Used for connecting to the RS485 signal port for controlling the power meter at the grid connection point	8	DIN1	Dry contact for grid scheduling	-
9	485B2	RS485 differential signal -		10	DIN2		
11	-	-		12	DIN3		
13	GND	GND		14	DIN4		
15	DIN5	Rapid shutdown ^a /NS protection ^b		16	GND		
<p>Note a: For details about the rapid shutdown function, see Rapid Shutdown.</p> <p>Note b: For details about the NS protection function, see Connecting NS Protection Signal Cables.</p>							

Communication Modes

Figure 5-28 SmartLogger networking

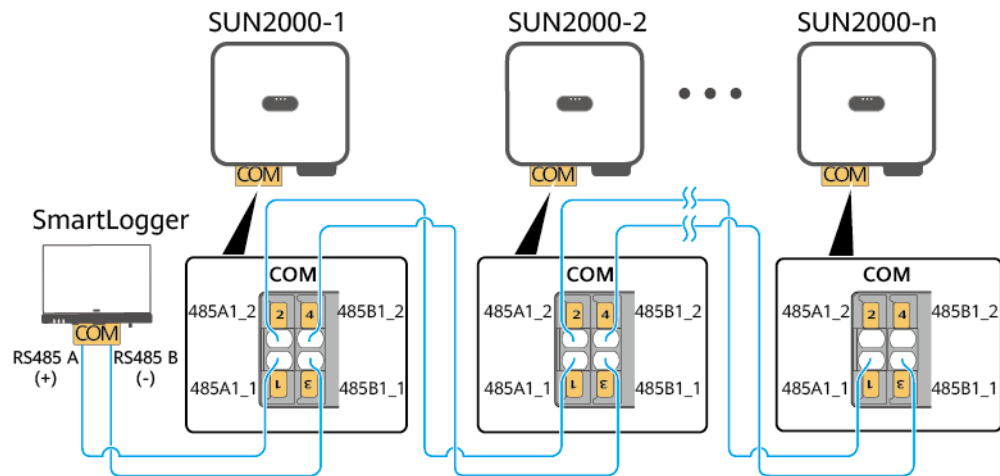

NOTE

- If the inverter is connected to the SmartLogger, it cannot be connected to the Smart Dongle.
- A maximum of 80 devices can be connected to one SmartLogger. You are advised to connect less than 30 devices to each RS485 route.

Figure 5-29 Smart Dongle networking

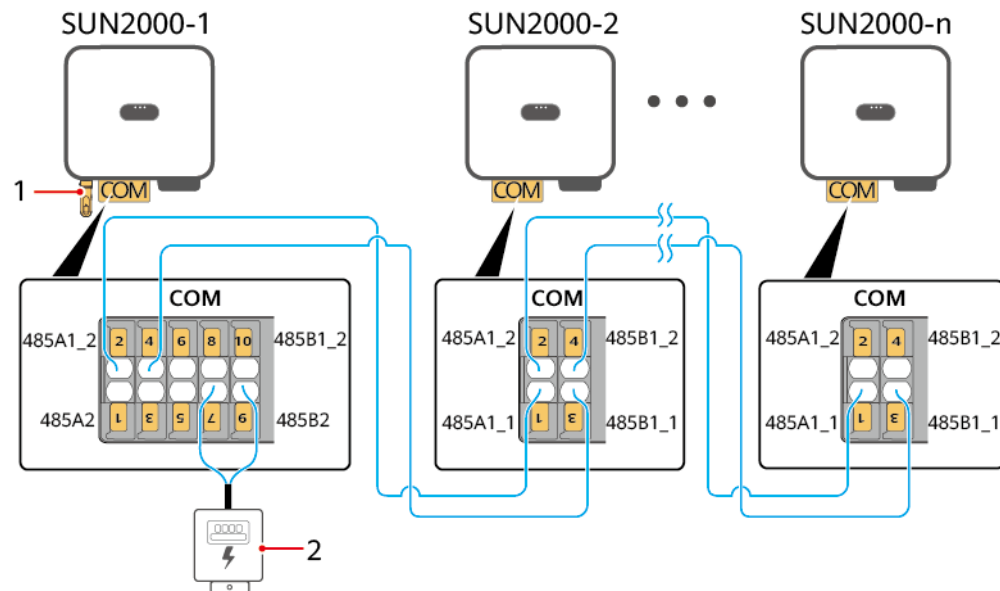

(1) Smart Dongle

(2) Power meter

NOTE

- If the inverter is connected to the Smart Dongle, it cannot be connected to the SmartLogger.
- A power meter is required for export limitation. Select a power meter based on the site requirements.
- The power meter and Smart Dongle must be connected to the same inverter.
- To ensure quick responses of the system, you are advised to connect the power meter separately to a COM port.

5.7.1.1 Connecting the RS485 Communications Cable (Inverter Cascading)

Cable Connection

The following figure shows the cable connections for inverter cascading.

Figure 5-30 Cable connection

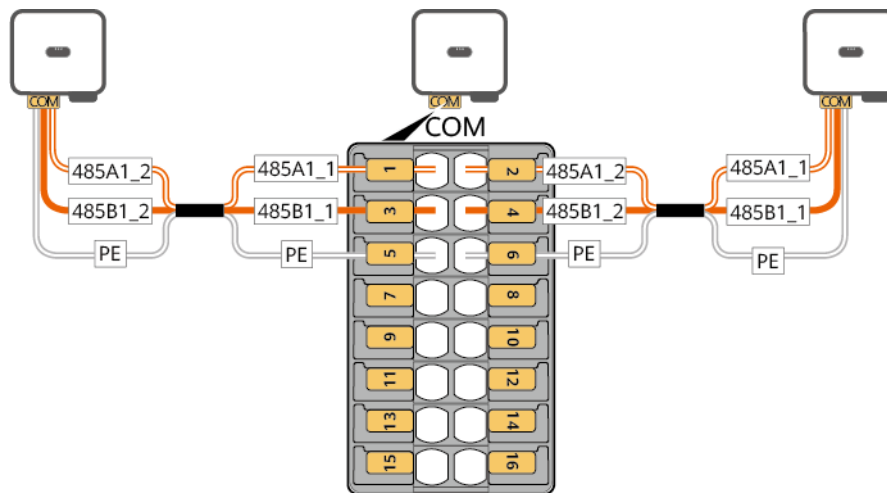

Procedure

- Step 1** Connect the signal cable to the signal cable connector.

Figure 5-31 Installing the cable

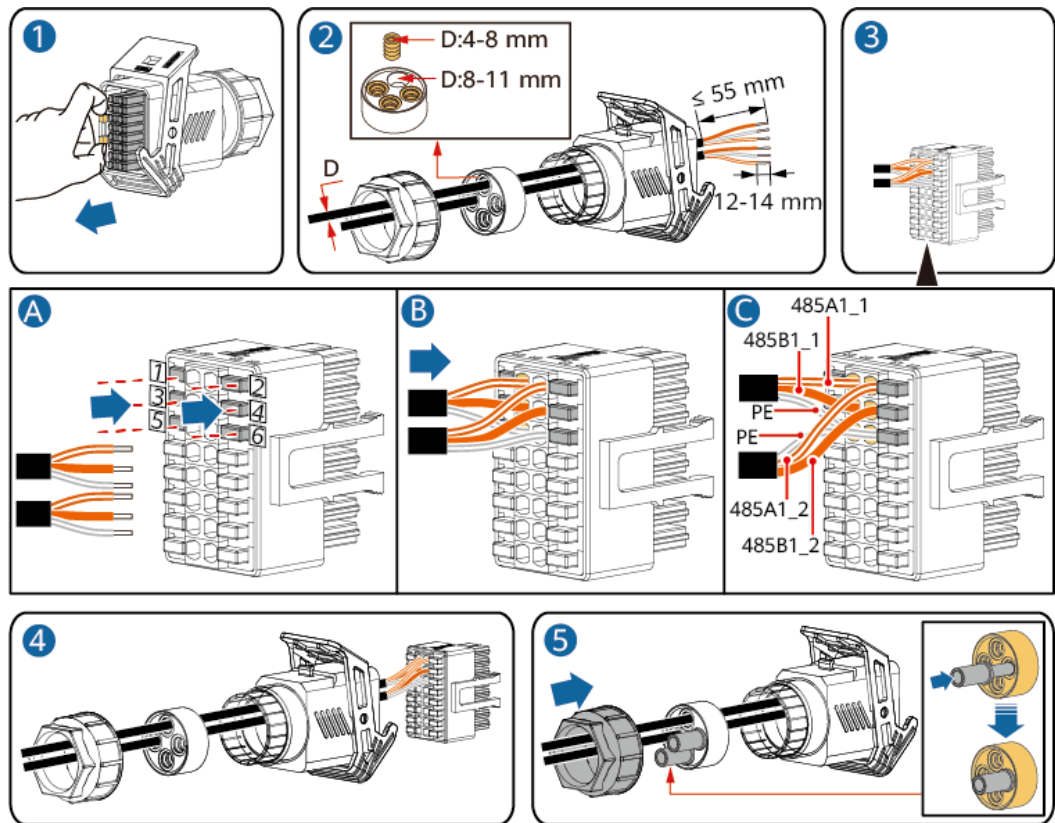

Step 2 Connect the signal cable connector to the COM port.

Figure 5-32 Securing the signal cable connector

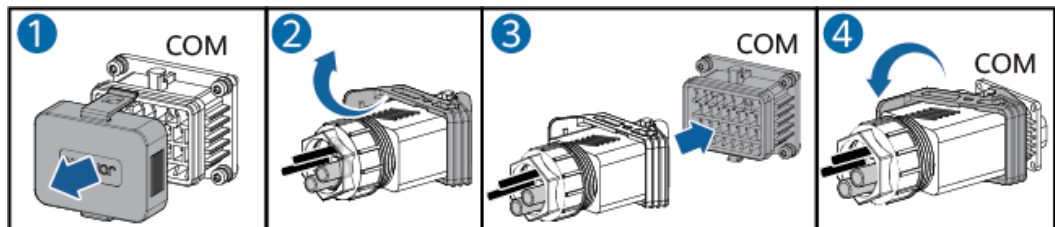

----End

5.7.1.2 Connecting the RS485 Communications Cables (SmartLogger)

Cable Connection

The following figure shows the cable connection between the inverter and the SmartLogger.

Figure 5-33 Cable connection

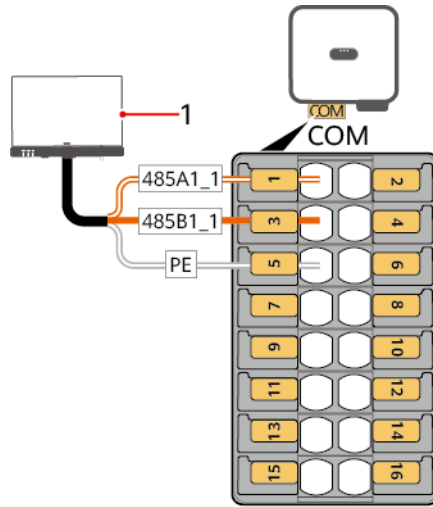

(1) SmartLogger

Procedure

Step 1 Connect the signal cable to the signal cable connector.

Figure 5-34 Installing the cable

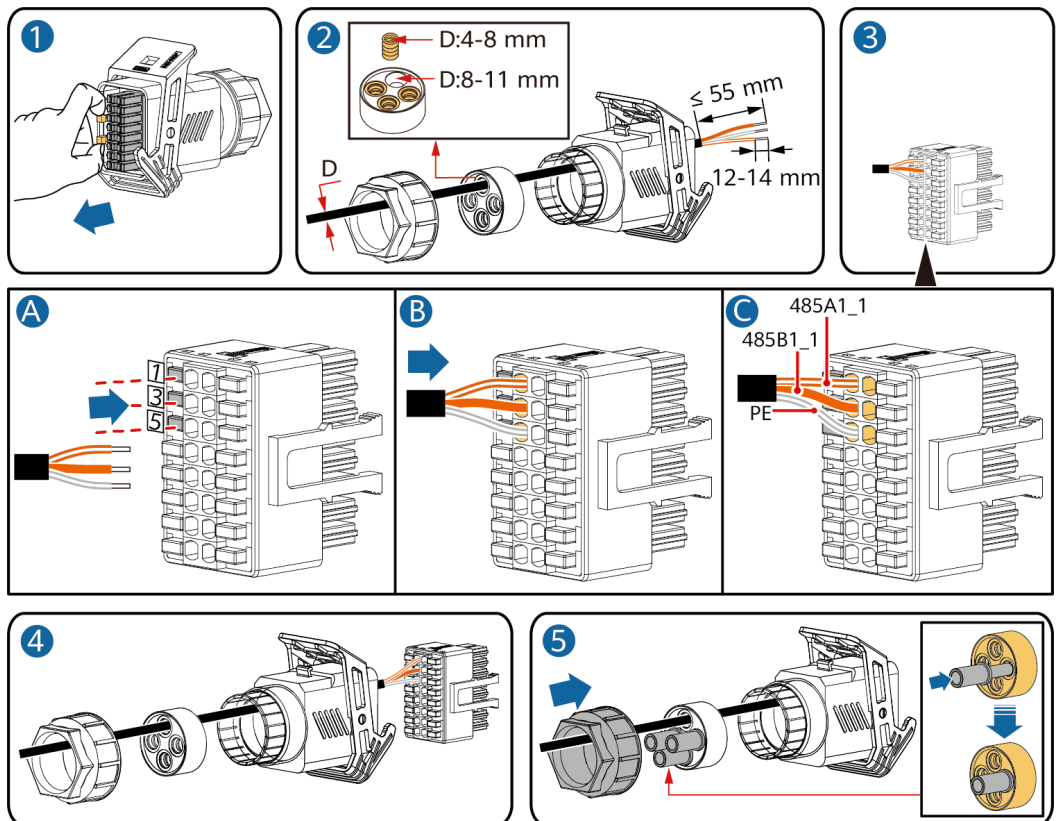

Step 2 Connect the signal cable connector to the COM port.

Figure 5-35 Securing the signal cable connector

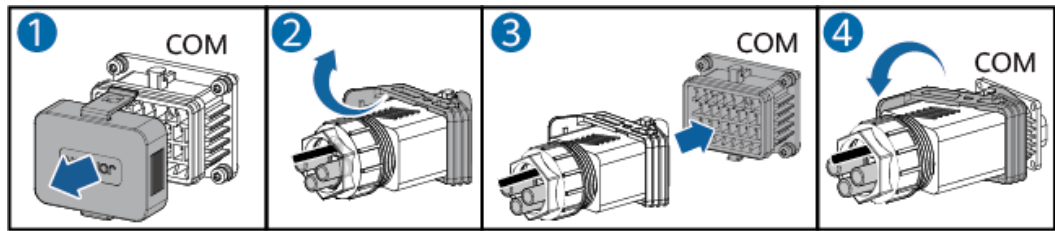

----End

5.7.1.3 Connecting the RS485 Communications Cable (Power Meter)

Cable Connection

The following figure shows the cable connection between the inverter and the power meter.

Figure 5-36 Cable connection

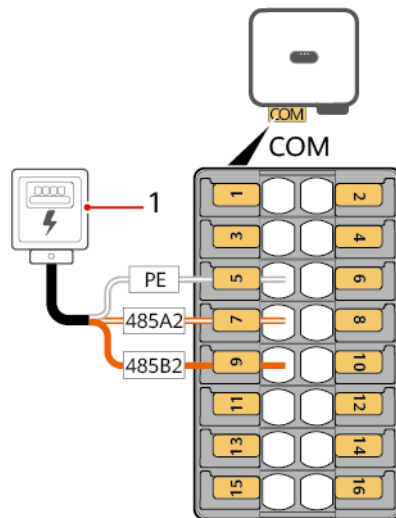

(1) Power meter

NOTE

A power meter is required for export limitation. Select a power meter based on the site requirements.

Procedure

Step 1 Connect the signal cable to the signal cable connector.

Figure 5-37 Installing the cable

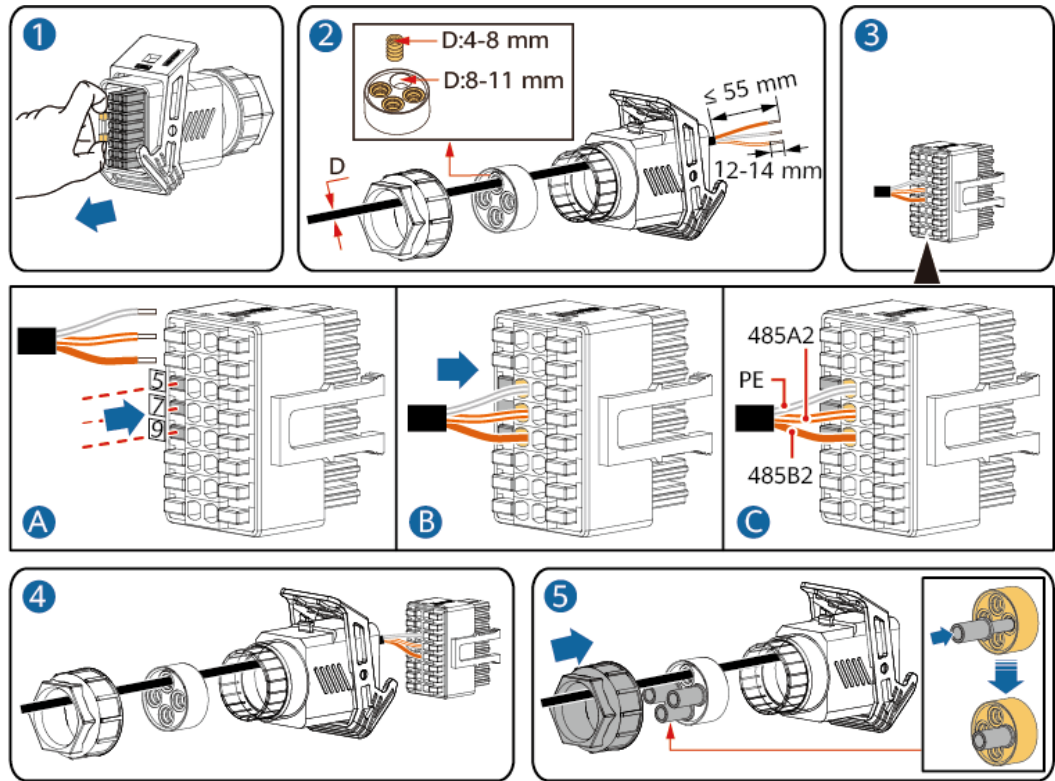

Step 2 Connect the signal cable connector to the COM port.

Figure 5-38 Securing the signal cable connector

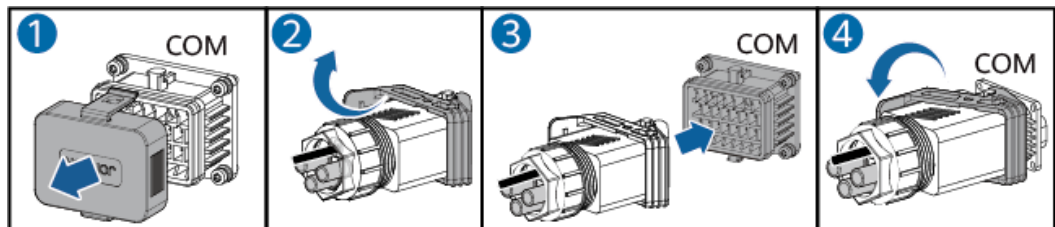

----End

5.7.1.4 Connecting the Grid Scheduling Signal Cable

Cable Connection

The following figure shows the cable connection between the inverter and the ripple control device.

Figure 5-39 Cable connection

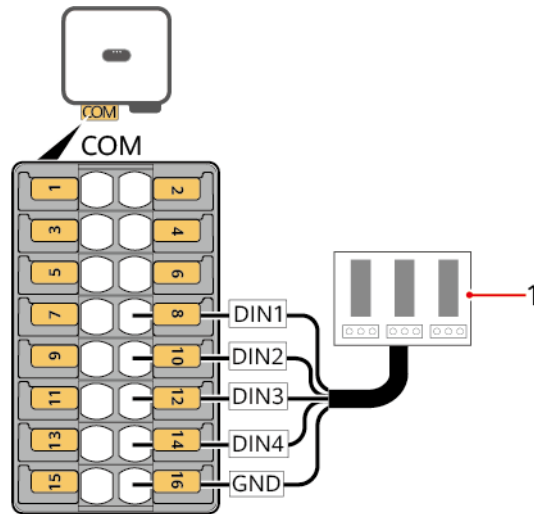

(1) Ripple control device

Procedure

Step 1 Connect the signal cable to the signal cable connector.

Figure 5-40 Installing the cable

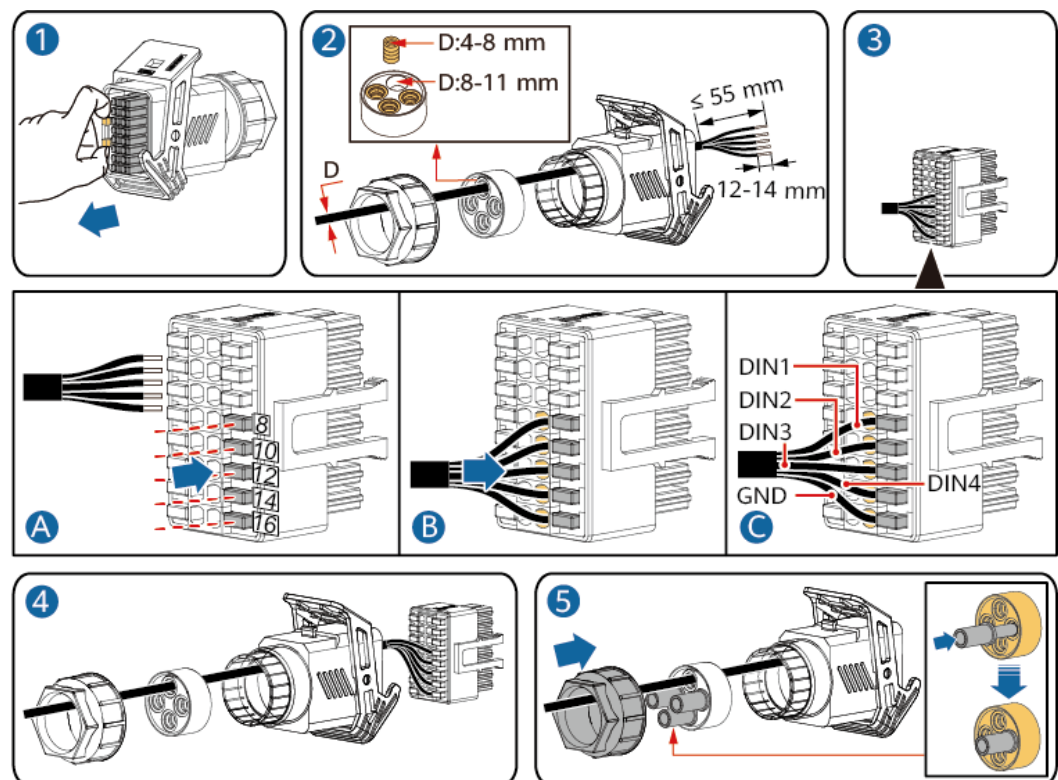

Step 2 Connect the signal cable connector to the COM port.

Figure 5-41 Securing the signal cable connector

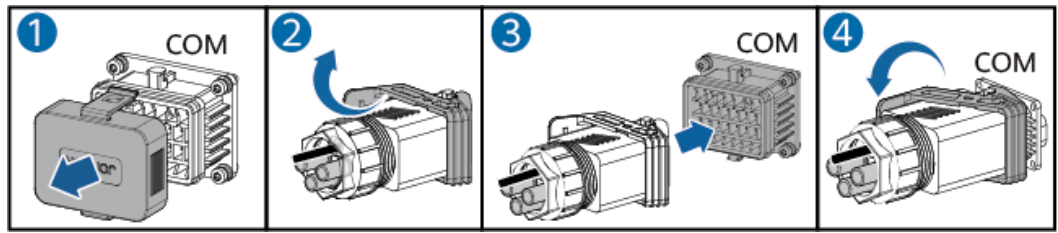

----End

5.7.1.5 Connecting the Rapid Shutdown Signal Cable

Cable Connection

The following figure shows the cable connection between the inverter and the rapid shutdown device.

Figure 5-42 Cable connection

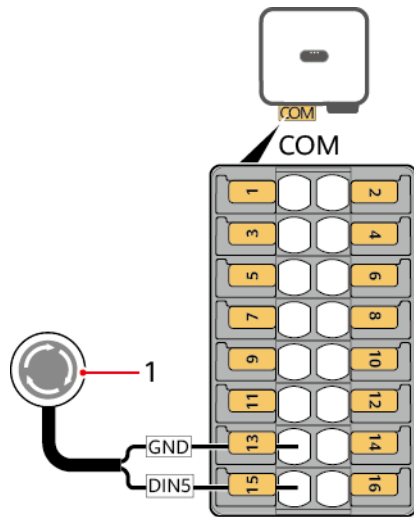

(1) Rapid shutdown device

NOTICE

- If optimizers are configured for all PV modules connected to the inverter, the PV system can perform a rapid shutdown. The rapid shutdown function is not supported if optimizers are configured for some PV modules.
- To use the DI rapid shutdown function, connect the switch to DIN5 (pin 15) and GND (pin 13) at the communications terminal of the inverter. The switch shall be closed by default. When the switch is opened, rapid shutdown is triggered. The distance between the switch and the farthest inverter must be less than or equal to 10 m.
- Log in to the local commissioning screen as **Installer**, choose **Set > Feature parameters > Dry contact function**, and set the dry contact function to **DI rapid shutdown**.
- DI rapid shutdown and NS protection use the same DIN5 (pin 15) and GND (pin 13). Therefore, you can use only either of the functions.

Procedure

Step 1 Connect the signal cable to the signal cable connector.

Figure 5-43 Installing the cable

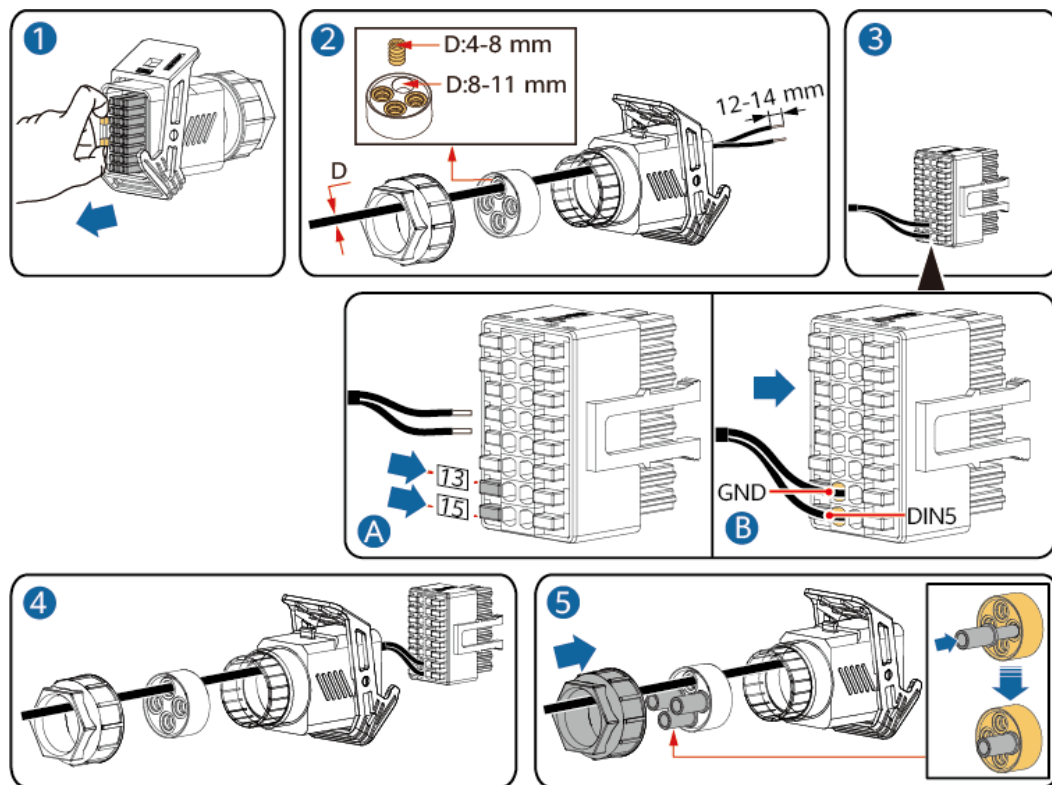

Step 2 Connect the signal cable connector to the COM port.

Figure 5-44 Securing the signal cable connector

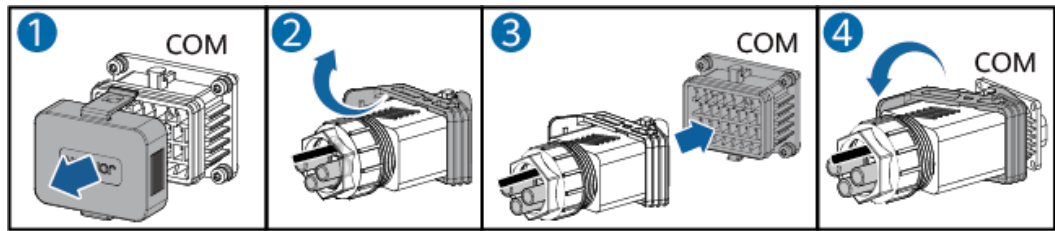

----End

5.7.1.6 Connecting the NS Protection Signal Cable

Cable Connection

The following figure shows the cable connection between the inverter and the NS protection switch.

Figure 5-45 Connecting cascaded inverters to the NS protection switch

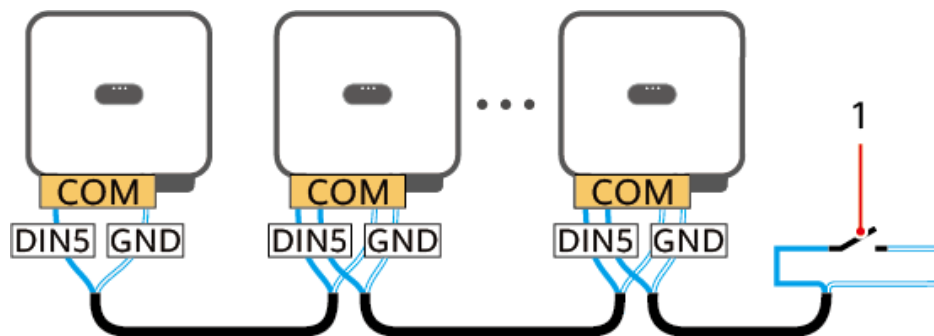

(1) NS protection switch

NOTE

- The NS protection function applies to areas that comply with the VDE 4105 standard.
- To use the NS protection function, connect the switch to DIN5 (pin 15) and GND (pin 13) at the communications terminal of the inverter. The switch shall be closed by default. When the switch is opened, NS protection is triggered.
- The cable connection method for a single inverter is the same as that for cascaded inverters. For a single inverter, connect GND and DIN5 to the same cable.
- Log in to the local commissioning screen as **Installer**, choose **Set > Feature parameters > Dry contact function**, and set the dry contact function to **NS protection**. To enable NS protection for multiple inverters, set **Dry contact function** to **NS protection** for each inverter.
- DI rapid shutdown and NS protection use the same DIN5 (pin 15) and GND (pin 13). Therefore, you can use only either of the functions.

Procedure

Step 1 Connect the signal cable to the signal cable connector (for inverter cascading).

Figure 5-46 Connecting the cable

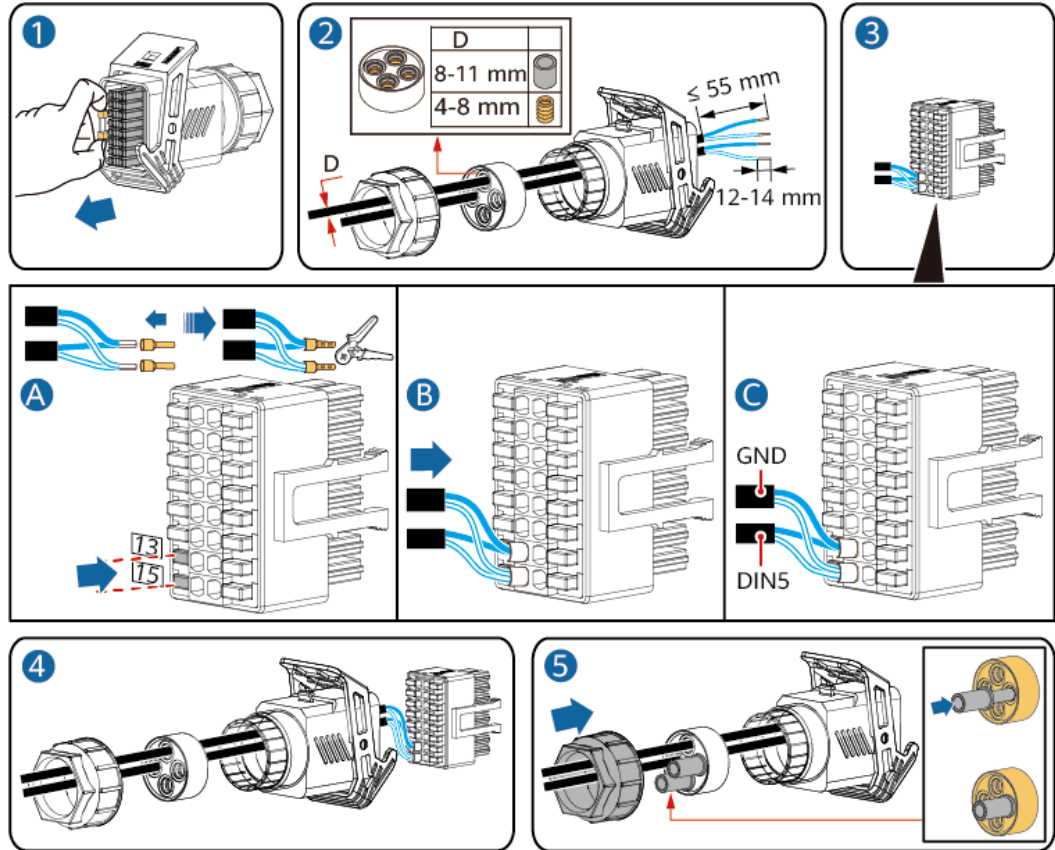

Step 2 Connect the signal cable connector to the COM port.

Figure 5-47 Securing the signal cable connector

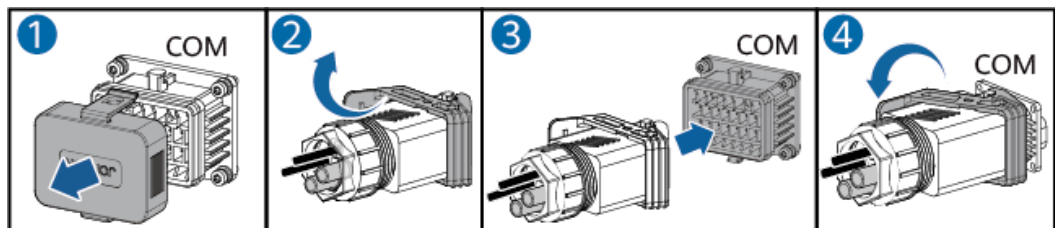

----End

5.7.2 Scenario Where No Signal Cable Is Connected

NOTICE

If no signal cable is connected to the inverter, use a waterproof plug to seal the cable hole of the signal cable connector and connect the signal cable connector to the communications port on the inverter for better waterproof performance.

Figure 5-48 Connecting the signal cable connector

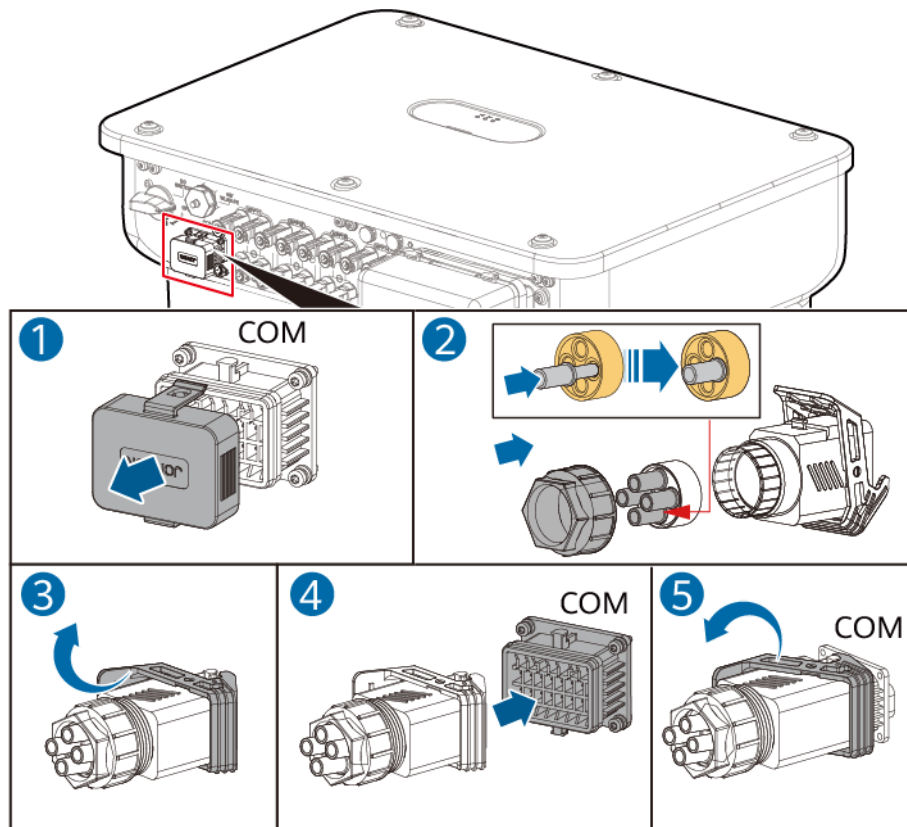

6 Check Before Power-On

Table 6-1 Checklist

No.	Check Item	Expected Result
1	Inverter	The inverter is installed correctly and securely.
2	Smart Dongle	The Smart Dongle is installed correctly and securely.
3	Cable routing	Cables are routed properly as required by the customer.
4	Cable tie	Cable ties are evenly distributed and no sharp edge exists.
5	Grounding	Ground cables are connected correctly and securely.
6	Switch	All DC SWITCH and other switches connected to the inverter are turned off.
7	Cable connections	The AC output power cable, DC input power cables, and signal cables are connected correctly and securely.
8	Unused terminals and ports	Unused terminals and ports are locked by waterproof glands.
9	Installation environment	The installation space is proper, and the installation environment is clean and tidy without foreign objects.

7 Power-On and Commissioning

7.1 Powering On the Inverter

Prerequisites

 **DANGER**

Wear PPE and use dedicated insulated tools to avoid electric shocks or short circuits.

Precautions

NOTICE

- Before the equipment is put into operation for the first time, ensure that the parameters are set correctly by professional personnel. Incorrect parameter settings may result in noncompliance with local grid connection requirements and affect the normal operations of the equipment.
 - Before turning on the AC switch between the inverter and the grid, check that the AC voltage is within the specified range using a multimeter.
 - If the DC power supply is connected but the AC power supply is disconnected, the inverter will report the **Grid Failure** fault. The inverter can start properly only after the fault is automatically rectified.
-

Procedure

- Step 1** At the AC switch between the inverter and the power grid, use a multimeter to measure the grid voltage and ensure that the voltage is within the allowed operating voltage range of the inverter. If the voltage is not in the allowed range, check the circuits.

- Step 2** Turn on the AC switch between the inverter and the power grid.
- Step 3** Turn on the DC switch (if any) between the PV strings and the inverter.
- Step 4** Set the **DC SWITCH** at the bottom of the inverter to **ON**.
- Step 5** Observe the LED indicators to check the status of the inverter.

Table 7-1 LED indicator description

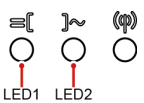
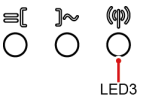
Category	Status		Description
Running indication 	LED1	LED2	-
	Steady green	Steady green	The inverter is running in on-grid state.
	Blinking green slowly (on for 1s and off for 1s)	Off	The DC is on and the AC is off.
	Blinking green slowly (on for 1s and off for 1s)	Blinking green slowly (on for 1s and off for 1s)	Both the DC and AC are on, and the inverter is off-grid.
	Off	Blinking green slowly (on for 1s and off for 1s)	The DC is off and the AC is on.
	Off	Off	Both the DC and AC are off.
	Blinking red fast (on for 0.2s and off for 0.2s)	-	There is a DC environmental alarm.
	-	Blinking red fast (on for 0.2s and off for 0.2s)	There is an AC environmental alarm.
	Steady red	Steady red	A fault exists.
Communi cation indication 	LED3		-
	Blinking green fast (on for 0.2s and off for 0.2s)		Communication is in progress.
	Blinking green slowly (on for 1s and off for 1s)		A mobile phone is connected to the inverter.
	Off		There is no communication.

Category	Status			Description
	LED1	LED2	LED3	
Device replacement indication	Steady red	Steady red	Steady red	The inverter hardware is faulty and needs to be replaced.

Step 6 (Optional) Observe the Smart Dongle LED indicator to check the status of the Smart Dongle.

Figure 7-1 4G Smart Dongle

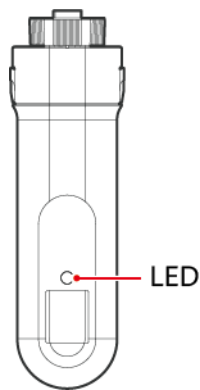

NOTE

For details about the LED indicator and running status of the 4G Smart Dongle, see [SDongleB-06 Smart Dongle Quick Guide \(4G\)](#).

Figure 7-2 WLAN-FE Smart Dongle

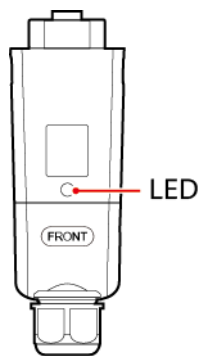

NOTE

For details about the LED indicator and running status of the WLAN-FE Smart Dongle, see [SDongleA-05 Smart Dongle Quick Guide \(WLAN-FE\)](#).

----End

7.2 Commissioning Methods and Process

Figure 7-3 Commissioning process on the app

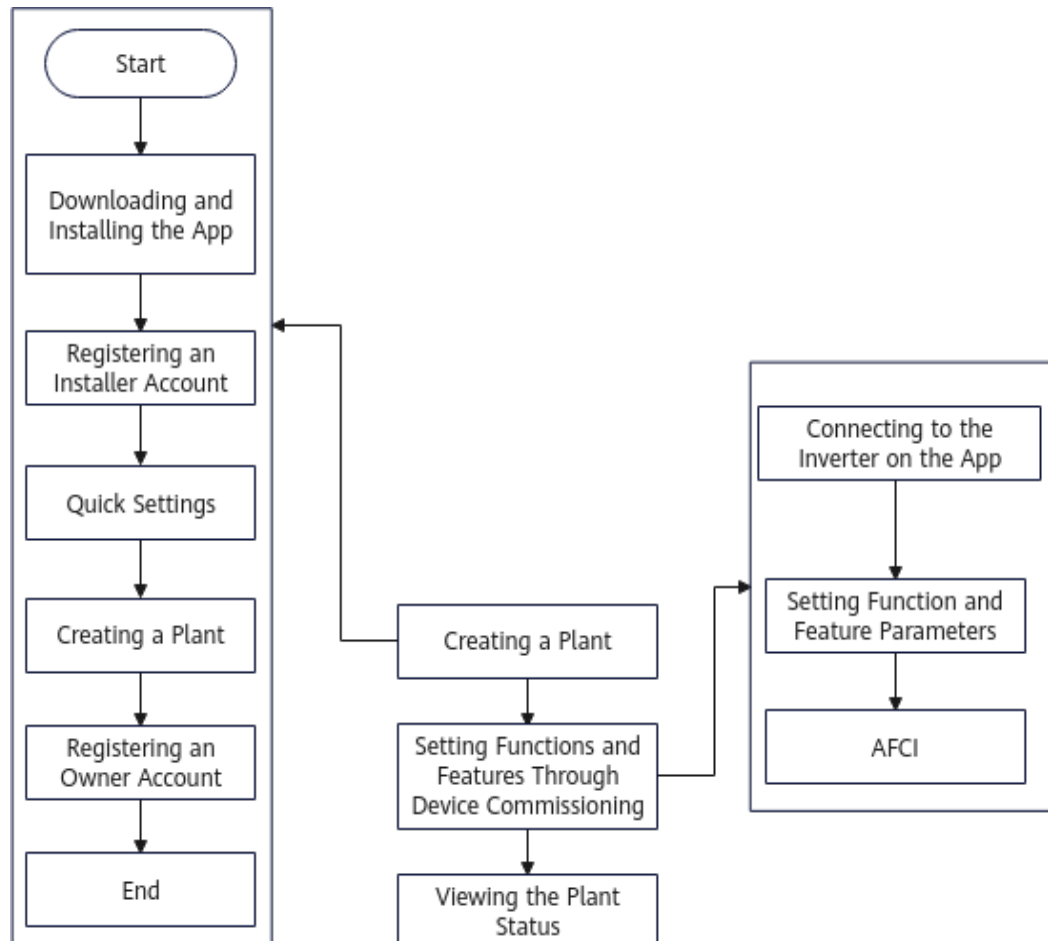

7.3 Commissioning the Inverter (Using the App)

7.3.1 Creating a Plant

7.3.1.1 Downloading and Installing the FusionSolar App

For details, see [Downloading and Installing the App](#) in the *FusionSolar App User Manual*.

7.3.1.2 Registering an Installer Account

For details about how to create the first **Installer** account, see [Registering the Company's First Installer Account](#) in the *FusionSolar App User Manual*.

For details about how to create multiple **Installer** accounts for the same company, see **Registering an Owner Account or Another Installer Account** in the *FusionSolar App User Manual*.

7.3.1.3 Quick Settings

Step 1 Log in to the FusionSolar app as **Installer**, tap **Setup wizard** on the **Home** screen, scan the QR code on the device, and follow the instructions to connect to the device WLAN.

Figure 7-4 Logging in to the app

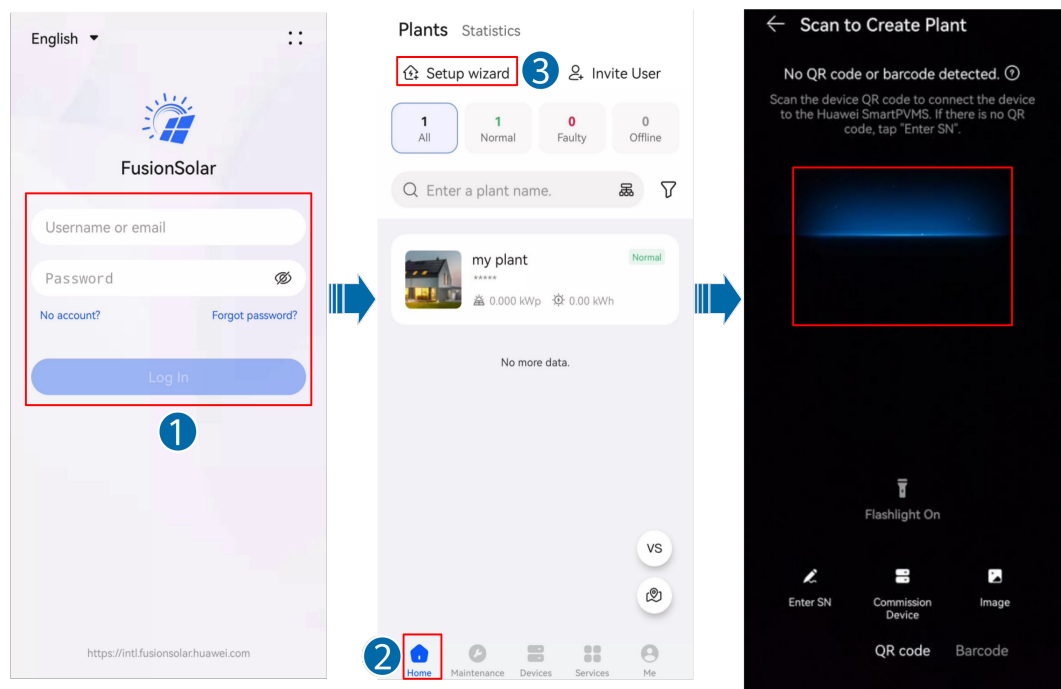

NOTE

- Before tapping **Setup wizard**, ensure that the app is connected to the Internet. If the network connection is abnormal, QR code scanning may fail. In this case, perform operations as prompted on the app.
- If SmartLogger networking is adopted, scan the QR code on the SmartLogger to connect to the device WLAN as prompted.
- If Smart Dongle networking is adopted, scan the QR code on the master inverter to connect to the device WLAN as prompted.
- If the inverter has a built-in WLAN, the WLAN of the Smart Dongle is disabled by default. If the inverter does not have a WLAN, the WLAN of the Smart Dongle is enabled by default.
- If the WLAN of the Smart Dongle is disabled, log in to the FusionSolar app and tap the plant name on the **Home** screen to access the plant screen. Choose **Devices**, tap the Smart Dongle name, choose **O&M Authorization > WLAN wakeup**, and tap **OK** to enable the WLAN of the Smart Dongle.

 **NOTE**

- The WLAN name of a device consists of "Device name-Device SN." (The last six digits of the WLAN names of some devices are the same as the last six digits of the device SNs.)
- For the first-time connection, log in with the initial password. You can obtain the initial WLAN password from the device label, that is, the characters following "Password (or PSW)". If the device label does not contain the "Password (or PSW)" field, the initial password is **Changeme**.
- Ensure account security by changing the password periodically. Your password might be stolen or cracked if it is left unchanged for extended periods. If a password is lost, the device cannot be accessed. In these cases, the Company shall not be liable for any loss.
- If the login screen is not displayed after you scan the QR code, check whether your phone is correctly connected to the device WLAN. If not, manually select and connect to the WLAN.
- If **This WLAN network has no Internet access. Connect anyway?** message is displayed when you connect to the built-in WLAN, tap **CONNECT**. Otherwise, you cannot log in to the system. The actual UI and messages may vary with mobile phones.

Step 2 Log in to the local commissioning screen as **Installer** and access **Quick Settings**.

 **NOTE**

- Set the login password as prompted at the first login.
- To ensure account security, protect the login password by changing it periodically, and keep it secure.

Figure 7-5 Home screen for local commissioning

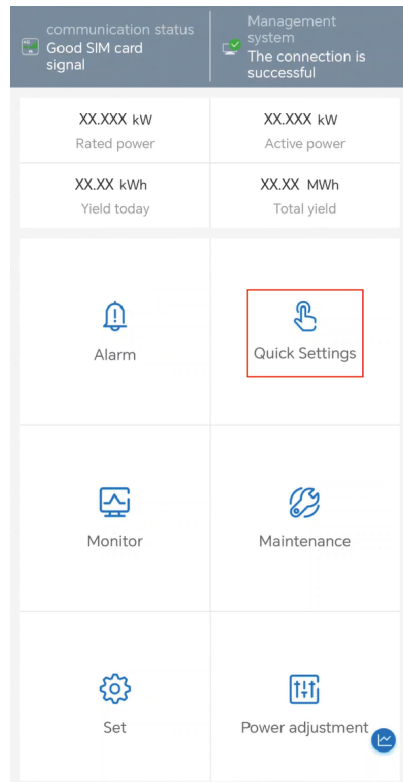

Step 3 Perform deployment and commissioning according to the **Quick Settings** process.

Figure 7-6 Basic parameters (using SmartLogger5000B networking as an example)

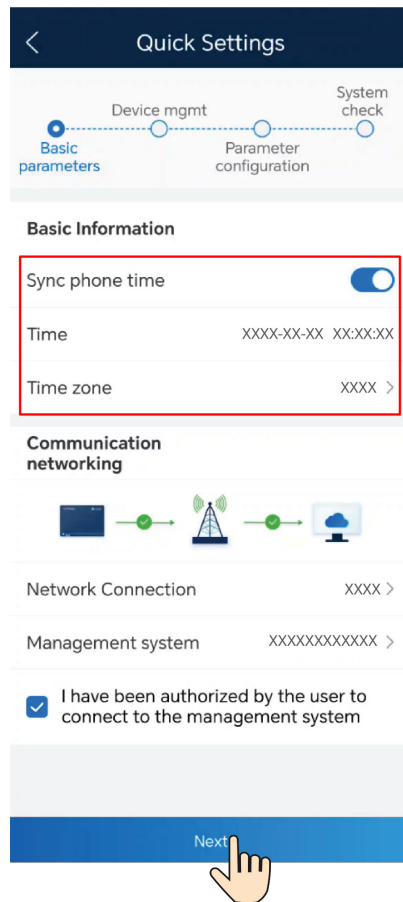

Table 7-2 Quick settings

Item	Description
Basic parameters	Set Basic Information based on the region.
Device Management	<ul style="list-style-type: none"> Huawei-developed devices, such as the inverter, can be automatically detected and do not need to be configured. Check whether the number and model of devices are consistent with the actual situation. Auto discovery does not apply to third-party devices. You need to tap + to add them manually.
Parameter configuration	Set Grid code based on the region. For details about Grid code , see A Grid Codes .
System check	After the current screen is displayed, the system automatically checks Networking state , Alarm status , and Device status . After the check is complete, you can tap Check Again to perform the check again.

 NOTE

- In **Quick Settings**, **Grid code** is **N/A** by default (automatic startup is not supported). Set **Grid code** based on the region where the plant is located.
- Before the inverter is put into operation for the first time, ensure that the parameters are set correctly by professional personnel. Incorrect parameter settings may result in noncompliance with local grid connection requirements and affect the normal operations of the equipment.

Step 4 Tap **Next** and connect devices to a plant as prompted.

----End

7.3.1.4 Creating a Plant

For details, see [Connecting to a Plant](#) in the *FusionSolar App User Manual*.

7.3.1.5 Registering an Owner Account

For details, see [Registering an Owner Account or Another Installer Account](#) in the *FusionSolar App User Manual*.

7.3.2 Setting Functions and Features Through Device Commissioning

7.3.2.1 Connecting to the Inverter on the App

For details, see [B Connecting to a Device on the App \(the Device Supports WLAN\)](#).

7.3.2.2 Setting Function and Feature Parameters

- To set more parameters, tap **Set** on the home screen of the inverter.
 - For details about the SmartLogger3000A or SmartLogger3000B parameters, see [FusionSolar App and SUN2000 App Device Commissioning Guide](#).
 - For details about the SmartLogger5000B or SmartMGC5000B parameters, see [FusionSolar App and SUN2000 App Device Commissioning Guide \(SmartLogger5000B and SmartMGC5000B\)](#).
- To set **Power adjustment** parameters, tap **Power adjustment** on the home screen of the inverter.
 - For details about the SmartLogger3000A or SmartLogger3000B parameters, see [FusionSolar App and SUN2000 App Device Commissioning Guide](#).
 - For details about the SmartLogger5000B or SmartMGC5000B parameters, see [FusionSolar App and SUN2000 App Device Commissioning Guide \(SmartLogger5000B and SmartMGC5000B\)](#).

7.3.2.2.1 Setting Grid-tied Point Control

Function

The output power of the PV power system can be limited or reduced to ensure that the output power is within the specified range.

Procedure

1. [Connect to the inverter on the app](#) and log in to the local commissioning screen of the device.
2. On the home screen of the inverter, choose **Power adjustment** > **Grid-tied Point Control** and perform operations as required.

Figure 7-7 Grid-tied point control

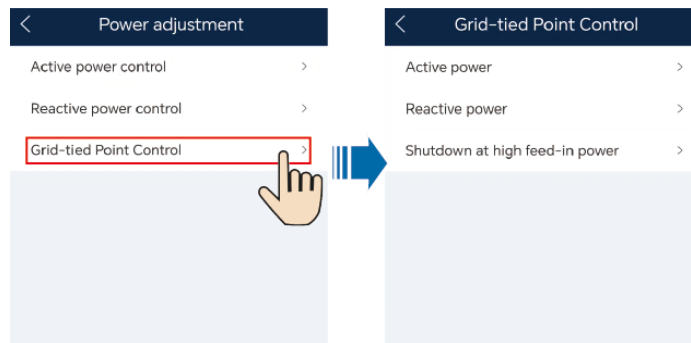

NOTE

For details about parameters in **Grid-tied Point Control**, see [FusionSolar App and SUN2000 App Device Commissioning Guide](#).

NOTE

- **Communication disconnection fail-safe** must be used together with **Grid connected with zero power** or **Limited Feed-in**. If **Grid connected with zero power** or **Limited Feed-in** is disabled, you are advised not to enable **Communication disconnection fail-safe**. Otherwise, the inverter will enter the unnecessary output power protection state.
- If **Grid connected with zero power** or **Limited Feed-in** is disabled, the inverter automatically disables **Communication disconnection fail-safe**. If **Grid connected with zero power** or **Limited Feed-in** is enabled again, determine whether to manually enable **Communication disconnection fail-safe** based on networking requirements.

7.3.2.2.2 Setting Feed-in at Limited Current

Function

- The output current of the PV power system can be limited or reduced to ensure that the output current is within the specified range.
- This function applies only to the commercial and industrial (C&I) scenarios in the UK where the grid code is G99-TYPEA-LV, G99-TYPEB-LV, G99-TYPEB-HV, G99-TYPEB-HV-MV480, or G99-TYPEA-HV.

Prerequisites

- The inverter has been connected to a power meter.
- The grid code has been correctly set for the inverter.
- The FusionSolar app version is 6.24.00.563 or later.

Procedure (Smart Dongle Networking)

NOTICE

In Smart Dongle networking, only one inverter can be connected to the power grid.

1. **Connect to the inverter on the app** and log in to the local commissioning screen of the device.
2. On the home screen, choose **Power adjustment > Grid-tied Point Control > Feed-in at limited current** and perform operations as required.

Figure 7-8 Feed-in at limited current

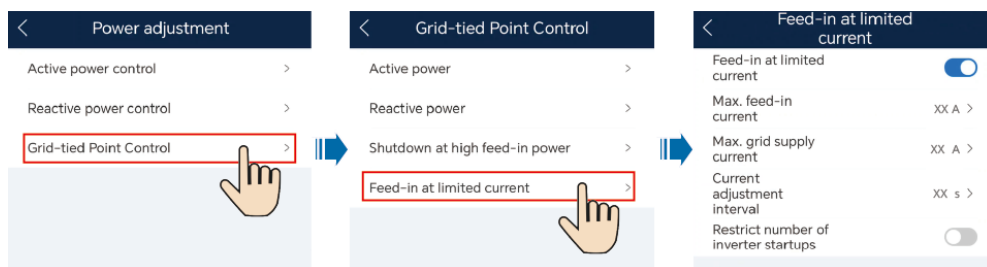

Table 7-3 Feed-in at limited current

Parameter		Description
Feed-in at limited current ^a	Feed-in at limited current	<p>The default value is Disabled.</p> <ul style="list-style-type: none"> • If this parameter is set to Disabled, feed-in at limited current is disabled. • If this parameter is set to Enable, feed-in at limited current is enabled.
	Max. feed-in current ^b	<p>Value range: [0, 30000 A]</p> <ul style="list-style-type: none"> • Due to external disturbances, the feed-in current may exceed the specified value by 2%. In this case, the inverter will adjust the current to a value within the range limit. • After the user changes the maximum feed-in current, the inverter will adjust the current to a value within the range limit.

Parameter		Description
	Max. grid supply current	Value range: [0, 30000 A] If the grid supply current exceeds the specified value by 2%, the inverter will adjust the current to a value within the range limit.
	Current adjustment interval	Value range: [1, 5s] You are advised to keep the default value. A larger value indicates a lower current adjustment speed. If this parameter is set to 2s and the current at the grid connection point exceeds the threshold, the inverter adjusts the current every 2s.
<p>Note a: If the inverter shuts down because the feed-in current adjustment is not complete within the specified time, the user needs to manually start the inverter. By default, the number of manual startups cannot exceed three within 30 days. If this limit is reached, it is not allowed to manually start the inverter again.</p> <p>Note b: If the maximum feed-in current is not adjusted to a value within the range limit in 15s, the inverter will shut down and report a Power Control Abnormal at Grid Connection Point alarm.</p>		

Procedure (SmartLogger5000 Networking)

NOTICE

- In SmartLogger networking, multiple inverters can be cascaded.
- SmartLogger: SmartLogger5000B or SmartMGC5000B

1. [Connect to the SmartLogger on the app](#) and log in to the local commissioning screen of the device.
2. On the home screen, choose **Power adjustment > Capacity Control** and perform operations as required.

Figure 7-9 Feed-in at limited current

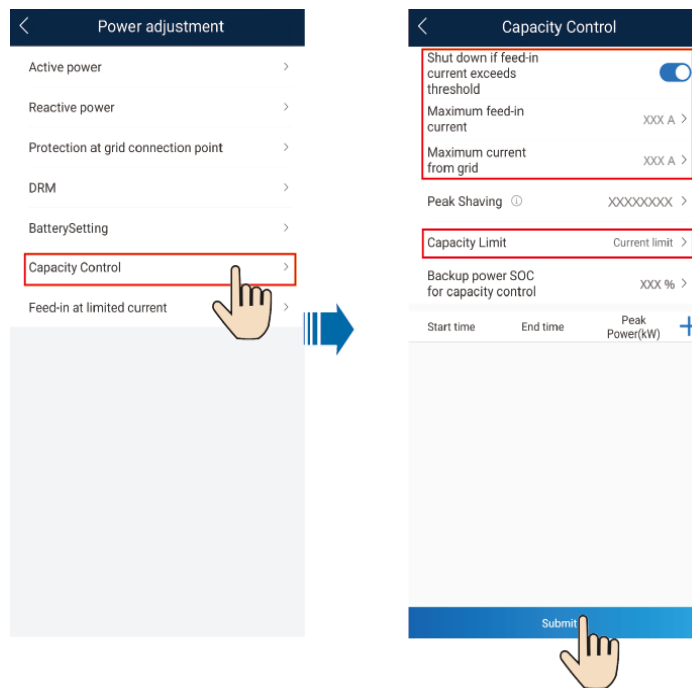

Table 7-4 Capacity control

Parameter	Description	Remarks
Capacity Limit	<ul style="list-style-type: none"> • No Control: disables this function. • Current limit: The current of electricity purchased from or sold to the grid cannot exceed the preset current limit. 	-
Maximum feed-in current (A)	Specifies the maximum feed-in current. If the maximum feed-in current is not adjusted to a value within the range limit within 15s, the inverter will shut down and report an alarm.	This parameter is displayed when Capacity Limit is set to Current limit .
Maximum current from grid (A)	Specifies the maximum current from grid.	
Shut down if feed-in current exceeds threshold	<p>After this parameter is enabled, the array will be forcibly shut down for 4 hours if the feed-in current exceeds the threshold. You are advised to use this parameter following the UK's G100 standard.</p> <p>NOTE If the inverter shuts down because the feed-in current adjustment is not complete within the specified timeframe, the user needs to manually start the inverter. By default, the user needs to wait for at least 4 hours before manually starting the inverter.</p>	This parameter is displayed when Capacity Limit is set to Current limit .

Parameter	Description	Remarks
Array startup	Specifies the startup of devices in the array.	This parameter is displayed when Shut down if feed-in current exceeds threshold is enabled.

Procedure (SmartLogger3000 Networking)

NOTICE

- In SmartLogger networking, multiple inverters can be cascaded.
- SmartLogger: SmartLogger3000A or SmartLogger3000B

1. **Connect to the SmartLogger on the app** and log in to the local commissioning screen of the device.
2. On the home screen, choose **Power adjustment > Feed-in at limited current**.

Figure 7-10 Feed-in at limited current

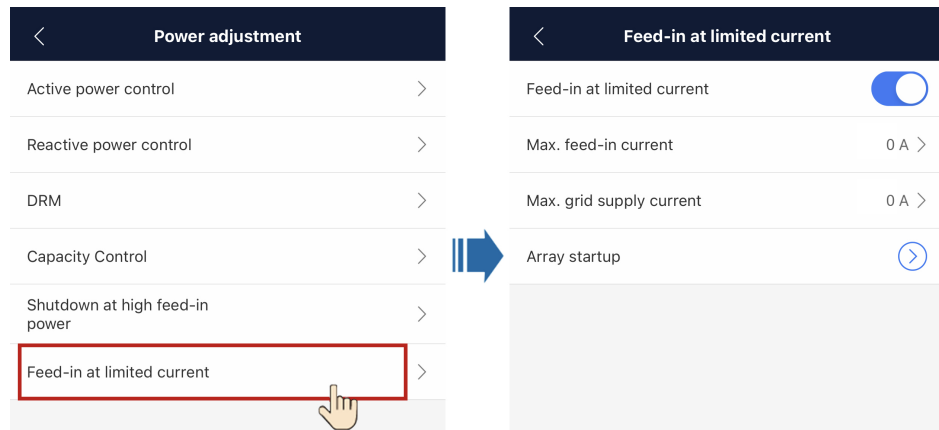

Table 7-5 Feed-in at limited current

Parameter		Description
Feed-in at limited current ^a	Feed-in at limited current	The default value is Disable . <ul style="list-style-type: none"> • If this parameter is set to Disable, feed-in at limited current will be unavailable. • If this parameter is set to Enable, feed-in at limited current will be available.
	Max. feed-in current ^b	Value range: [0, 30000 A] <ul style="list-style-type: none"> • Due to external disturbances, the feed-in current may exceed the specified value by 2%. In this case, the inverter will adjust the current to a value within the range limit. • After the user changes the maximum feed-in current, the inverter will adjust the current to a value within the range limit.
	Max. grid supply current	Value range: [0, 30000 A] If the grid supply current exceeds the specified value by 2%, the inverter will adjust the current to a value within the range limit.
	Array startup	If devices in the array shut down because the feed-in current at the grid connection point is not complete, you can start all inverters in the array by one click.

Note a: If the inverter shuts down because the feed-in current adjustment is not complete within the specified time, the user needs to manually start the inverter. By default, the user needs to wait for at least 4 hours before starting the inverter.

Note b: If the maximum feed-in current is not adjusted to a value within the range limit within 15s, the inverter will shut down and report a **Power Control Abnormal at Grid Connection Point** alarm.

7.3.2.2.3 Setting Output Apparent Power Control

Procedure

1. [Connect to the inverter on the app](#) and log in to the local commissioning screen of the device.
2. On the home screen of the inverter, choose **Set > Power adjustment** and set the inverter parameters.

Figure 7-11 Apparent power control

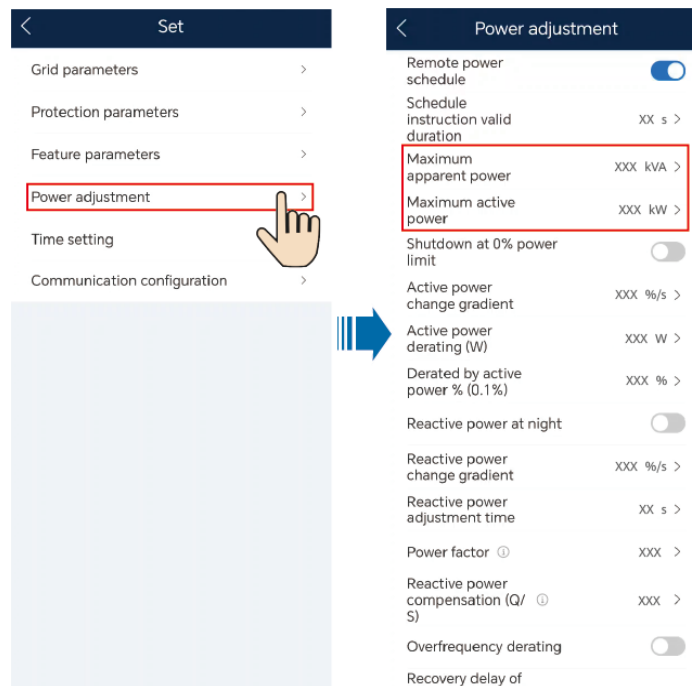

Table 7-6 Apparent power control

Parameter	Description	Value Range
Maximum apparent power (kVA)	Specifies the output upper threshold for the maximum apparent power to adapt to the capacity requirements of standard and customized inverters.	[Maximum active power , S_{max}]
Maximum active power (kW)	Specifies the output upper threshold for the maximum active power to adapt to different market requirements.	[0.1, P_{max}]

NOTE

The lower threshold for **Maximum apparent power** is **Maximum active power**. To lower **Maximum apparent power**, lower **Maximum active power** first.

7.3.2.2.4 Setting RCD Parameters

Function

A residual current device (RCD) detects residual current (that is, leakage current of an electrical system to ground, including the residual current of an inverter to the ground and the residual current of a PV module to the ground), and automatically disconnects the inverter from the power grid when residual current exceeds the preset threshold.

Procedure

1. **Connect to the inverter on the app** and log in to the local commissioning screen of the device.
2. Choose **Set > Feature parameters**. Set the parameters **RCD enhancing** and **Current Threshold for Triggering RCD Protection** as required.

Parameter	Description
Current Threshold for Triggering RCD Protection	<p>Sets the residual current threshold for triggering RCD protection. If the residual current of the electrical system to ground is greater than the current threshold for triggering RCD protection, the inverter shuts down due to RCD protection.</p> <p>NOTICE</p> <ul style="list-style-type: none"> • If the current threshold for triggering RCD protection is set to a smaller value, the inverter is more likely to be shut down due to RCD protection. Exercise caution when setting this parameter. • Adjusting the current threshold for triggering RCD protection may cause the inverter to frequently trigger the protection mechanism. In this case, you can increase the threshold to disable the protection mechanism. Exercise caution when setting this parameter. If you have any questions, contact the vendor or manufacturer.
RCD enhancing	<p>Enables or disables the RCD enhancement function.</p> <ul style="list-style-type: none"> • Enable: enables the RCD enhancement function. If the RCD enhancement function is enabled, the residual current of the inverter will decrease. You are advised to enable this function if an AC switch with a residual current detection function is installed outside the inverter or the inverter operates in a humid environment (for example, on rainy days) and the inverter frequently triggers RCD protection. • Disabled: disables the RCD enhancement function. <p>NOTICE Enabling the RCD enhancement function may cause power derating of the inverter.</p>

7.3.2.2.5 Setting Dry Contact Scheduling

NOTICE

- In the inverter parallel connection scenario with Smart Dongle networking, log in to the SmartLogger to set parameters.
- In the inverter parallel connection scenario with Smart Dongle networking, log in to the inverter connected to the Smart Dongle to set parameters.

Function

This function applies to scenarios where the grid company performs remote scheduling through dedicated ripple control receivers. The grid company remotely sends a scheduling command (%) to the plant with a wireless transmitting apparatus. Then, the wireless receiving apparatus receives the scheduling command and converts it into a DI signal. The plant monitoring device controls the inverter to output the corresponding power.

Ensure that the inverter is correctly connected to the ripple control receiver when setting this function. (In Germany and some other European areas, the grid company uses the ripple control receiver to convert a power grid scheduling signal to a dry contact signal, and the power plant uses a dry contact to receive the signal.)

NOTE

When the functions of limited feed-in or zero feed-in and scheduling via the DI port are enabled at the same time, the system calculates the output power thresholds for both functions respectively, and then sends the smaller value to the inverter.

Procedure

1. **Connect to the inverter on the app** and log in to the local commissioning screen of the device.
2. Choose **Set > Power adjustment > Dry contact scheduling settings**.
3. Enable **Dry contact scheduling** and set related parameters as prompted.

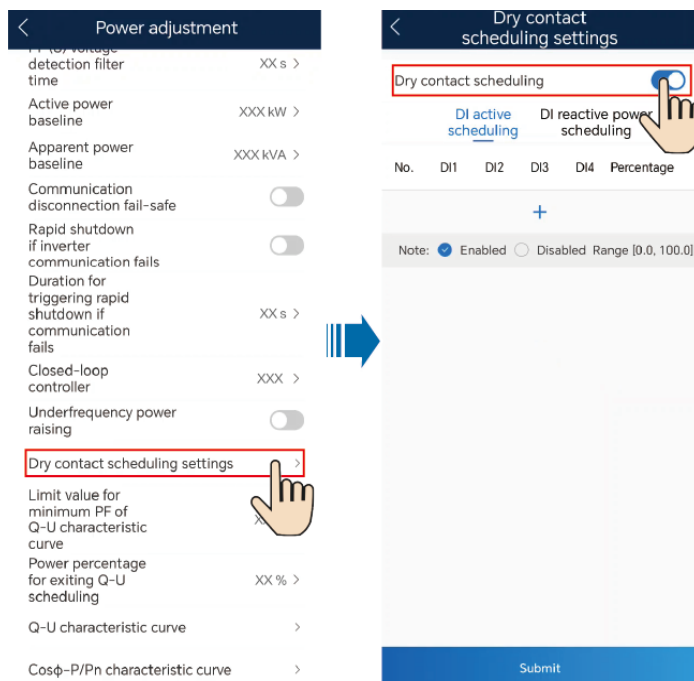

Parameter	Description
DI active scheduling	Sets the DI scheduling signals and the corresponding active output power percentage levels.

Parameter	Description
DI reactive power scheduling	Sets the DI scheduling signals and the corresponding reactive output power percentage levels.

 **NOTE**

- The two scheduling modes support 16 levels of percentages. The percentage levels of DI1–DI4 must differ from each other. Otherwise, an exception will occur during command parsing.
- If the actual input DI signal is inconsistent with the setting, an **Abnormal DI Instruction** alarm will be generated.

7.3.2.2.6 Setting PV String Access Detection

Function

- **PV string access detection** applies to large-scale commercial and utility-scale PV plants with PV strings facing the same direction.
- **PV string access detection** is used to detect and identify the operating status of PV strings connected to an inverter. After the parameters are set, you can choose **Device monitoring** > **Detail** to view the PV string access status, which can be **Not connected**, **Single string – normal**, **2-in-1 string – normal**, **Single string – loss**, **2-in-1 string – full loss**, **2-in-1 string – single string loss**, or **Unidentified**. Enable this function if you need to detect the PV string status. Otherwise, disable this function.
- In AC or DC power limiting scenarios:
 - If the PV string access type is not identified, **PV Status** will be displayed as **Not connected**. The PV string access type can be identified only when the inverter restores to the non-power limiting state and the current of all connected PV strings reaches **Startup current**.
 - If the PV string access type has been identified, when a certain PV string connected to the 2-in-1 terminals is lost, no alarm will be generated. If a certain PV string connected to the 2-in-1 terminals is restored, the access type cannot be identified. You can determine whether both 2-in-1 PV strings are restored only after the PV string current reaches **Startup current for 2-in-1 detection**.

Procedure

1. [Connect to the inverter on the app](#) and log in to the local commissioning screen of the device.
2. On the home screen of the inverter, choose **Maintenance** > **PV string access detection** to access the parameter setting screen.

Figure 7-12 PV string access detection

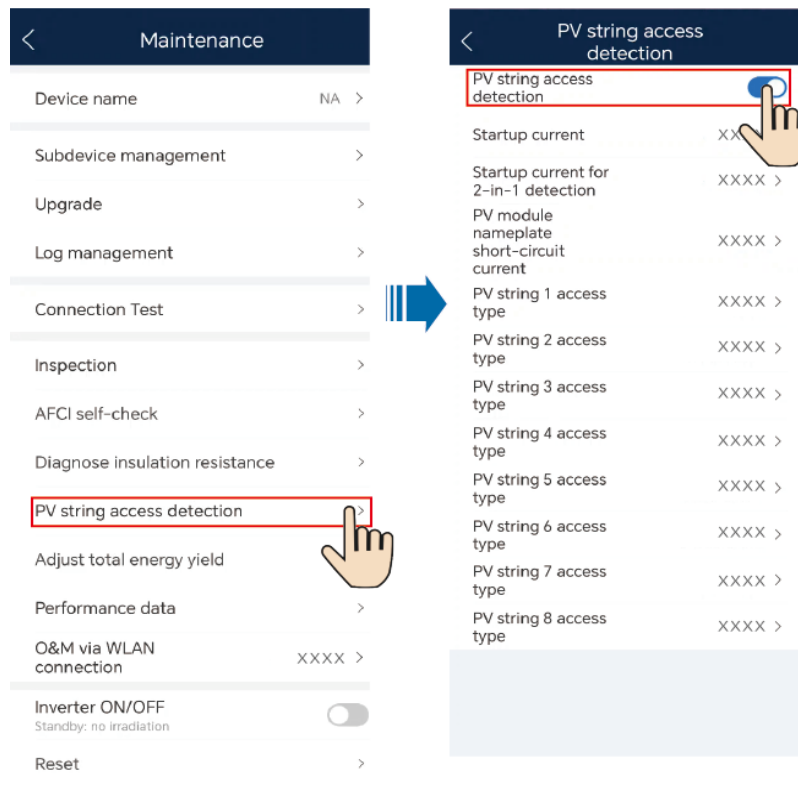

Parameter	Description	Remarks
PV string access detection	The default value of PV string access detection is Disabled . After the inverter connects to the power grid properly, you can set this parameter to Enable .	-
Startup current	When the current of all connected PV strings reaches the preset value, the PV string access detection function is enabled. NOTE Startup current setting rules: <ul style="list-style-type: none"> Startup current = $I_{sc} (S_{TC}) \times 0.6$ (rounded up). For details about $I_{sc} (S_{TC})$, see the PV module nameplate. Default startup current (5 A): applicable to the scenarios where the short-circuit current $I_{sc} (S_{TC})$ is greater than 8 A for the monocrystalline and polycrystalline PV modules. 	This parameter is displayed when PV string access detection is set to Enable .
Startup current for 2-in-1 detection	When the current of a PV string reaches the threshold specified by Startup current for 2-in-1 detection , the PV string is automatically identified as 2-in-1. The default value is recommended.	

Parameter	Description	Remarks
PV string <i>N</i> access type NOTE <i>N</i> is the DC input terminal number of the inverter.	<ul style="list-style-type: none"> Set this parameter based on the type of the PV string connected to DC input terminal <i>N</i> of the inverter. Options: Automatic identification (default value), Not connected, Single string - normal, and 2-in-1 string - normal The default value is recommended. If the value is incorrectly set, the PV string access type may be incorrectly identified and false alarms may be generated for the PV string access status. 	

7.3.2.2.7 Setting Built-in PID Recovery

NOTICE

Ensure that the inverter PE cable is securely connected. Otherwise, the built-in PID recovery function may be unavailable and electric shocks may occur.

Procedure

1. **Connect to the inverter on the app** and log in to the local commissioning screen of the device.
2. On the home screen of the inverter, choose **Set > Feature parameters** and set related parameters.

Figure 7-13 Setting PID suppression parameters

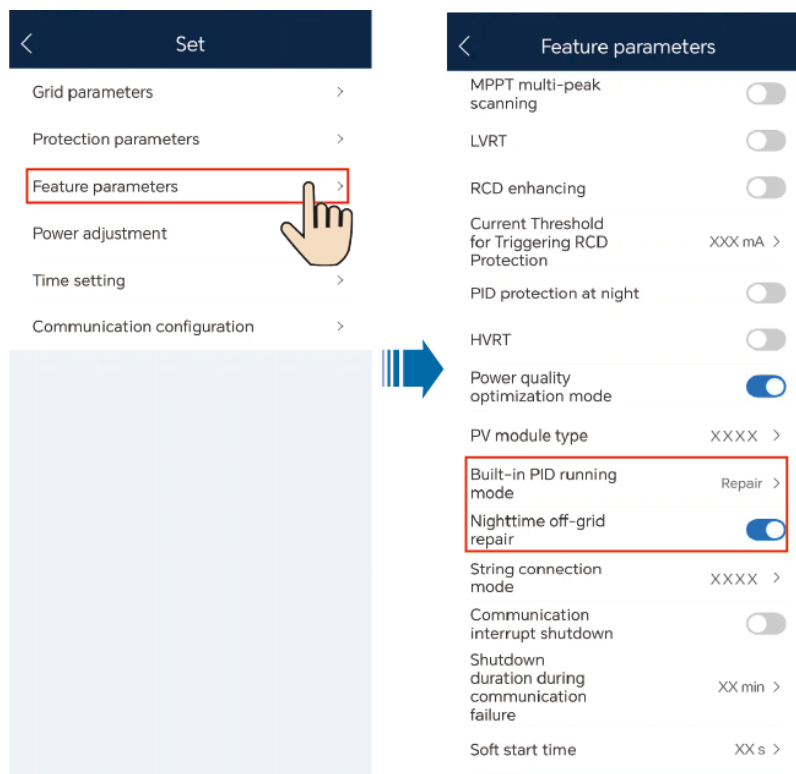

NOTE

- Set **Built-in PID running mode** to **Repair** (Disable by default).
- Set **nighttime off-grid repair** to . (This parameter is displayed when **Built-in PID running mode** is set to **Repair**.)

7.3.2.3 AFCI

Function Description

If PV modules or cables are incorrectly connected or damaged, electric arcs may be generated, which may cause fire. Huawei inverters provide unique arc fault detection in compliance with UL 1699B-2018 to safeguard users' lives and protect their property.

This function is enabled by default. The inverter automatically detects arc faults. To disable this function, log in to the FusionSolar app, choose **Services > Device Commissioning**, connect to the inverter WLAN as prompted, log in to the device, choose **Set > Feature parameters** on the home screen, and disable **AFCI**.

NOTE

The AFCI function works only with Huawei optimizers or ordinary PV modules when the inverter is connected to the grid, but does not support third-party optimizers or intelligent PV modules.

Clearing Alarms

The AFCI function involves the **DC arc fault** alarm.

The inverter has the AFCI alarm automatic clearance mechanism. If the alarm is triggered for less than five times within 24 hours, the inverter automatically clears the alarm. If the alarm is triggered for five times or more within 24 hours, the inverter locks for protection. You need to manually clear the alarm on the FusionSolar app or FusionSolar SmartPVMS so that it can work properly. You can manually clear the alarm in either of the following ways:

- **Method 1: FusionSolar app**
 - a. **Connect to the inverter that has generated the AFCI alarm using the app** and log in to the local commissioning screen of the device as an installer.
 - b. Tap **Alarm**. On the **Active alarm** screen, tap **Clear** on the right of the **DC arc fault** alarm to clear the alarm.

Figure 7-14 Clearing alarm

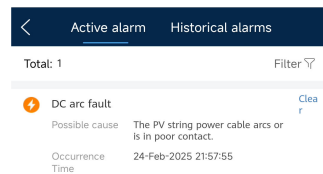

- **Method 2: FusionSolar SmartPVMS**
 - a. Log in to the FusionSolar SmartPVMS using an installer account, choose **Maintenance > Alarm Management**, select the **DC arc fault** alarm, and click **Clear**.

Figure 7-15 Clearing alarms

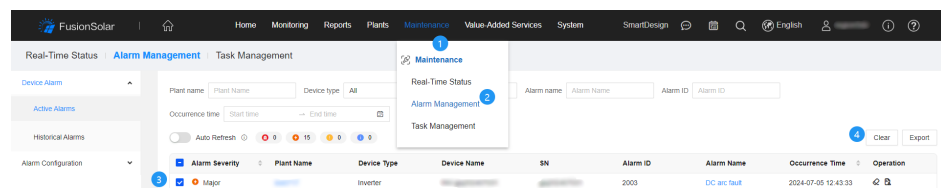

- b. Log in the FusionSolar SmartPVMS as a plant owner. Click the plant name on the **Home** page to access the plant page, and clear the alarm as prompted.

7.3.3 Viewing the Plant Status

The FusionSolar app provides an overview of plants. You can view the plant running status, energy yield and consumption, revenue, and energy flow diagram in real time.

Log in to the FusionSolar app. Choose **Home > Plants**. This screen displays the real-time running status and basic information of all plants managed by the user by default.

Figure 7-16 Viewing the plant status

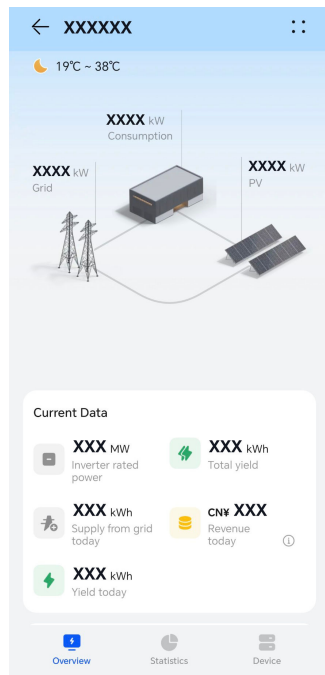

8 System Maintenance

 **DANGER**

- Wear personal protective equipment and use dedicated insulated tools to avoid electric shocks or short circuits.
-

 **WARNING**

- Before performing maintenance, power off the equipment, follow the instructions on the delayed discharge label, and wait for a period of time as specified to ensure that the equipment is not energized.
-

8.1 Routine Maintenance

To ensure that the inverter can operate properly for a long term, you are advised to perform routine maintenance on it as described in this section.

 **CAUTION**

Power off the system before cleaning the system, connecting cables, and checking grounding reliability.

Table 8-1 Maintenance checklist

Check Item	Check Method	Maintenance Method	Maintenance Interval
Alarm	Check alarms on the app, SmartLogger, or management system.	For details, see Inverter Alarm Reference . For details about alarm ID 2062, see 8.3 Locating Insulation Resistance Faults . Alarm 2032 "Grid Failure": If the inverter works with optimizers, rapid shutdown is triggered, but the alarm is not reported. Once grid power is restored, the optimizers automatically resume normal operation.	Routine maintenance
System cleanliness	Check periodically whether the heat sinks are blocked or dirty.	-	Once every 6 to 12 months
System running status	<ul style="list-style-type: none"> • Check whether the inverter is damaged or deformed. • Check whether the inverter generates abnormal sounds during operation. • Check whether all inverter parameters are correctly set during operation. 	Contact the Company's service engineers.	Once every 6 months

Check Item	Check Method	Maintenance Method	Maintenance Interval
Electrical connections	<ul style="list-style-type: none"> • Check whether cables are securely connected. • Check whether cables are damaged, especially whether the cable sheath that contacts a metal surface is damaged. • Check whether the sealing plugs of unused DC input terminals fall off. • Check whether the unused COM and USB ports are locked by waterproof caps. 	<ul style="list-style-type: none"> • Power off the inverter and secure loose or disconnected cables. • Power off the inverter and replace the damaged cables. • Install sealing plugs on unused DC input terminals. • Tighten the waterproof caps on the unused COM and USB ports. 	6 months after the first commissioning and once every 6 to 12 months after that
Grounding reliability	<p>Check whether the ground cable is securely grounded.</p> <p>Use a multimeter to check whether the ground resistance at the inverter ground screws is less than or equal to 4 Ω.</p>	Tighten the screws on both sides of the ground cable and ensure that the resistance meets the requirements.	6 months after the first commissioning and once every 6 to 12 months after that
Sealing	Check whether all terminals and ports are properly sealed.	-	Once 12 months
Vegetation around the inverter	Check whether there are weeds around the inverter.	<ul style="list-style-type: none"> • Perform inspection and weeding as required. • Clean the site promptly after weeding. 	Based on the local wilting season

8.2 Powering Off the System

Precautions

 **WARNING**

- After the inverter system is powered off, the remaining electricity and heat on the enclosure may cause electric shocks or burns. Therefore, wait for at least 5 minutes and wear insulated gloves before working on the inverter.
 - Before maintaining the optimizer and PV strings, power off the system by following the procedure. Otherwise, electric shocks may occur because the PV strings are energized.
-

Procedure

- Step 1** Send a shutdown command on the app.
 - Step 2** Turn off the AC switch between the inverter and the power grid.
 - Step 3** Set the **DC SWITCH** at the bottom of the inverter to **OFF**.
 - Step 4** Turn off the DC switch (if any) between the inverter and PV strings.
- End

8.3 Locating Insulation Resistance Faults

If the ground resistance of a PV string connected to the inverter is too low, the inverter generates a **Low insulation resistance** alarm.

The possible causes are as follows:

- A short circuit has occurred between the PV array and the ground.
- The ambient air of the PV array is damp and the insulation between the PV array and the ground is poor.

After the **Low insulation resistance** alarm is generated, the inverter automatically triggers insulation resistance fault location. If the fault location is successful, the location information is displayed on the **Alarm Details** screen of the **Low insulation resistance** alarm on the FusionSolar app.

Log in to the FusionSolar app, choose **Alarm > Current Alarms**, and choose **Low insulation resistance** to enter the **Alarm Details** screen.

Figure 8-1 Alarm details



NOTE

- The positive and negative terminals of a PV string are connected to the PV+ and PV- terminals of the inverter, respectively. The 0% position corresponds to the PV- terminal, and the 100% position corresponds to the PV+ terminal. Other percentages indicate that the fault occurs on a PV module or cable in the PV string.
- Possible fault position = Total number of PV modules in a PV string x Percentage of possible short-circuit positions. For example, if a PV string consists of 14 PV modules and the percentage of the possible short-circuit position is 34%, the possible fault position is 4.76 (14 x 34%), indicating that the fault is located near PV module 4, including the adjacent PV modules and their cables. The inverter has a detection precision of ±1 PV module.
- For details about the PV strings corresponding to the MPPT that may be faulty, see [Table 8-2](#). The fault can be located only to the MPPT level. Perform the following steps to connect the PV strings corresponding to the faulty MPPT to the inverter one by one to further locate and rectify the fault.
- When a non-short-circuit fault occurs, the possible short-circuit percentage is not displayed. If the insulation resistance is greater than 0.001 MΩ, the fault is not related to short circuit. Check all PV modules in the faulty PV string one by one to locate and rectify the fault.

Figure 8-2 Definition of the percentage of the short-circuit position (optimizers configured)

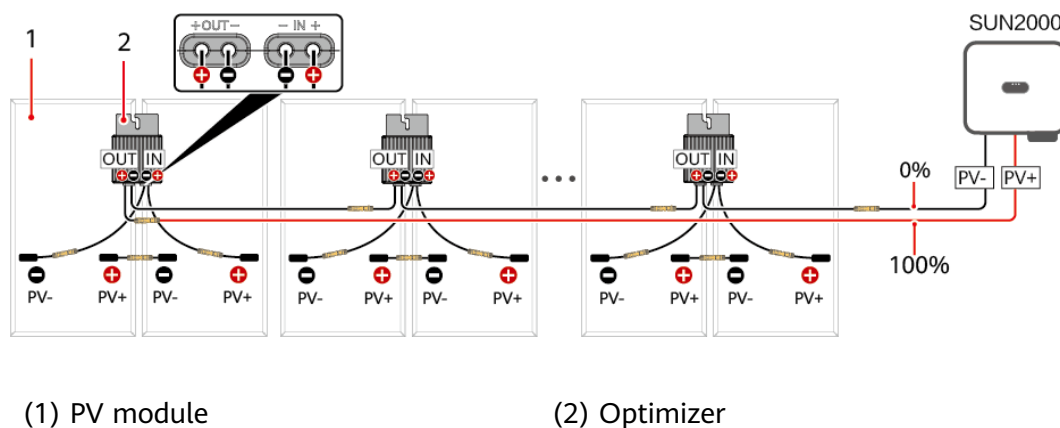

Figure 8-3 Definition of the percentage of the short-circuit position (optimizers not configured)

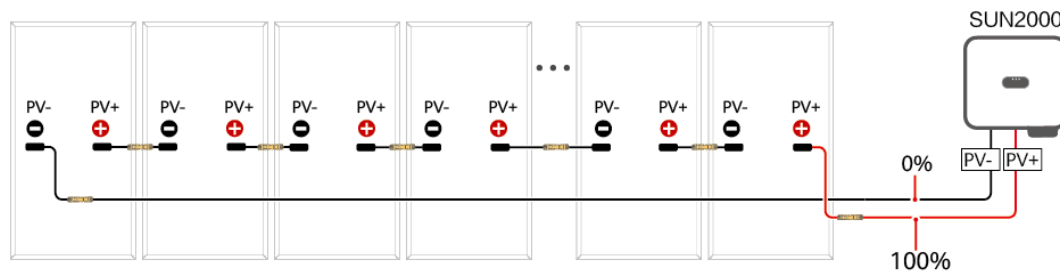

Table 8-2 Mapping between MPPTs and PV strings

MPPT n	PV String	MPPT n	PV String
MPPT1	PV1–PV2	MPPT2	PV3–PV4
MPPT3	PV5–PV6	MPPT4	PV7–PV8

Procedure

NOTICE

If the irradiance or the PV string voltage is too high, the insulation resistance fault may fail to be located. In this case, the fault location status on the **Alarm Details** screen is **Detection conditions not met**. Perform the following steps to connect PV strings to the inverter one by one to locate the fault. If the system is not configured with any optimizer, skip the corresponding operations.

- Step 1** Ensure that the AC connections are normal. Log in to the FusionSolar app, choose **Maintenance > Inverter ON/OFF** on the home screen, and send a shutdown command. Set the **DC SWITCH** of the inverter to **OFF**.
- Step 2** Connect a PV string to the inverter and set the **DC SWITCH** to **ON**. If the inverter status is **Shutdown: Command**, choose **Maintenance > Inverter ON/OFF** on the home screen and send a startup command.
- Step 3** Choose **Alarms** on the home screen of the app, access the **Current Alarms** screen, check whether a **Low insulation resistance** alarm is reported.
 - If no **Low insulation resistance** alarm is reported 1 minute after the DC side is powered on, choose **Maintenance > Inverter ON/OFF** on the home screen and send a shutdown command. Set the **DC SWITCH** to **OFF**. Go to **Step 2** and check the other PV strings one by one.
 - If the **Low insulation resistance** alarm is reported 1 minute after the DC side is powered on, check the percentage of possible short-circuit positions on the **Alarm details** screen and calculate the location of the possibly faulty PV module based on the percentage. Then go to **Step 4**.
- Step 4** Choose **Maintenance > Inverter ON/OFF** on the home screen of the app and send a shutdown command. Set the **DC SWITCH** to **OFF**. Check whether the

connectors or DC power cables between the optimizer and PV module, between adjacent PV modules, or between adjacent optimizers on the possible fault position are damaged.

- If yes, replace the damaged connectors or DC power cables and then set the **DC SWITCH** to **ON**. If the inverter status is **Shutdown: Command**, choose **Maintenance > Inverter ON/OFF** on the home screen and send a startup command. View alarm information.
 - If no **Low insulation resistance** alarm is reported 1 minute after the DC side is powered on, the insulation resistance fault location of the PV string is complete. Choose **Maintenance > Inverter ON/OFF** on the home screen of the app and send a shutdown command. Set the **DC SWITCH** to **OFF**. Go to **Step 2** and check the other PV strings one by one. Then, go to **Step 8**.
 - If the **Low insulation resistance** alarm is still reported 1 minute after the DC side is powered on, Choose **Maintenance > Inverter ON/OFF** on the home screen of the app and send a shutdown command. Set the **DC SWITCH** to **OFF** and go to **Step 5**.
- If no, go to **Step 5**.

Step 5 Disconnect the possibly faulty PV module and the corresponding optimizer from the PV string, and use a DC extension cable with MC4 connectors to connect the adjacent PV modules or optimizers. Set the **DC SWITCH** to **ON**. If the inverter status is **Shutdown: Command**, choose **Maintenance > Inverter ON/OFF** on the home screen of the app and send a startup command. View alarm information.

- If no **Low insulation resistance** alarm is reported 1 minute after the DC side is powered on, the fault occurred on the disconnected PV module and optimizer. Choose **Maintenance > Inverter ON/OFF** on the home screen of the app, send a shutdown command, and set the **DC SWITCH** to **OFF**. Go to **Step 7**.
- If the **Low insulation resistance** alarm is still reported 1 minute after the DC side is powered on, the fault did not occur on the disconnected PV module or optimizer. Go to **Step 6**.

Step 6 Choose **Maintenance > Inverter ON/OFF** on the home screen of the app and send a shutdown command. Set the **DC SWITCH** to **OFF**, reconnect the disconnected PV module and optimizer, and repeat **Step 5** to check the adjacent PV modules and optimizers at the possible fault position.

Step 7 Determine the position of the ground insulation fault.

- Disconnect the possibly faulty PV module from the optimizer.
- Connect the possibly faulty optimizer to the PV string.
- Set the **DC SWITCH** to **ON**. If the inverter status is **Shutdown: Command**, choose **Maintenance > Inverter ON/OFF** on the home screen and send a startup command. View alarm information.
 - If no **Low insulation resistance** is reported 1 minute after the DC side is powered on, the fault is on the possible faulty PV module.
 - If a **Low insulation resistance** is reported 1 minute after the DC side is powered on, the fault is on the possible faulty optimizer.
- Choose **Maintenance > Inverter ON/OFF** on the home screen of the app and send a shutdown command. Set **DC SWITCH** to **OFF**, replace the faulty

component, and complete troubleshooting the insulation resistance fault. Go to [Step 2](#) and check the other PV strings one by one. Then, go to [Step 8](#).

Step 8 Set the **DC SWITCH** to **ON**. If the inverter status is **Shutdown: Command**, choose **Maintenance > Inverter ON/OFF** on the home screen and send a startup command.

----End

9 Alarm Reference

For details about alarms, see [Inverter Alarm Reference](#).

10 Handling the Inverter

10.1 Removing the SUN2000

NOTICE

Before removing the SUN2000, disconnect both AC and DC connections.

Perform the following operations to remove the SUN2000:

1. Disconnect all cables from the SUN2000, including RS485 communications cables, DC input power cables, AC output power cables, and PGND cables.
2. Remove the SUN2000 from the mounting bracket.
3. Remove the mounting bracket.

10.2 Packing the SUN2000

- If the original packing materials are available, put the SUN2000 inside them and then seal them by using adhesive tape.
- If the original packing materials are not available, put the SUN2000 inside a suitable cardboard box and seal it properly.

10.3 Disposing of the SUN2000

If the SUN2000 service life expires, dispose of it according to the local disposal rules for electrical equipment waste.

11 Technical Specifications

Efficiency

Item	SUN2000-30K-MC0	SUN2000-40K-MC0
Maximum efficiency	98.7% (480 V)	98.7% (480 V)
	98.6% (400 V)	98.6% (400 V)
European efficiency	98.4% (400 V)	98.4% (400 V)

Input

Item	SUN2000-30K-MC0	SUN2000-40K-MC0
Maximum input voltage ^a	1100 V	1100 V
Rated input voltage	600 V (380 V/400 V)	600 V (380 V/400 V)
	650 V (440 V)	650 V (440 V)
	720 V (480 V)	720 V (480 V)
Minimum startup voltage	180 V	180 V
MPPT voltage range ^b	180–1000 V	180–1000 V
Full-load MPPT voltage range ^c	500–800 V (380 V/400 V)	540–800 V (380 V/400 V)
	625–850 V (440 V)	625–850 V (440 V)
	625–850 V (480 V)	625–850 V (480 V)
Number of inputs	8	8
Number of MPPT circuits	4	4
Maximum input current (per PV string)	23 A	23 A

Item	SUN2000-30K-MC0	SUN2000-40K-MC0
Maximum input current (per MPPT)	27 A	27 A
Maximum short-circuit current (per MPPT)	40 A	40 A

Note a: The maximum input voltage is the maximum DC input voltage that the inverter can withstand. If the input voltage exceeds this value, the inverter may be damaged.

Note b: If the input voltage is beyond the MPPT voltage range, the inverter cannot work properly.

Note c: The PV strings connecting to the same MPPT circuit shall use the same model and quantity of PV modules. It is recommended that the PV string voltage be higher than the lower threshold of the full-load MPPT voltage.

Output

Item	SUN2000-30K-MC0	SUN2000-40K-MC0
Rated output power	30 kW	40 kW
Maximum apparent power	33 kVA ^a	44 kVA
Maximum active power (cos ϕ = 1)	33 kW ^a	44 kW
Rated output voltage ^b	220/380 V 230/400 V 277/480 V 3W+(N) ^c +PE	220/380 V 230/400 V 277/480 V 3W+(N) ^c +PE
Rated output current	45.6 A (380 V) 43.3 A (400 V) 36.1 A (480 V)	60.8 A (380 V) 57.7 A (400 V) 48.1 A (480 V)
Maximum output current	50.4 A (380 V) 47.9 A (400 V) 39.9 A (480 V)	67.2 A (380 V) 63.8 A (400 V) 53.2 A (480 V)
Supported power grid frequency	50 Hz/60 Hz	50 Hz/60 Hz
Power factor	0.8 leading to 0.8 lagging	0.8 leading to 0.8 lagging

Item	SUN2000-30K-MC0	SUN2000-40K-MC0
Maximum total harmonic distortion (rated power)	< 3%	< 3%
Output DC component (DCI)	< 0.5% of the rated current	< 0.5% of the rated current

Note a: For certain grid codes, the maximum apparent power of the SUN2000-30K-MC0 is 30 kVA, and the maximum active power ($\cos\phi = 1$) is 30 kW.

Note b: The rated output voltage is determined by **Grid code**, which can be set on the app, SmartLogger, or management system.

Note c: You can determine whether to connect the N wire based on the application scenario. In scenarios without N wires, set **Output mode** to **Three-phase three-wire**. In scenarios with N wires, set **Output mode** to **Three-phase four-wire**.

Protection

Item	SUN2000-30K-MC0	SUN2000-40K-MC0
Input DC switch	Supported	Supported
Anti-islanding protection	Supported	Supported
Output overcurrent protection	Supported	Supported
Input reverse polarity protection	Supported	Supported
PV string fault detection	Supported	Supported
Insulation resistance detection	Supported	Supported
Built-in PID recovery	Supported	Supported
Arc-fault circuit interrupter (AFCI)	Supported	Supported
Residual current monitoring unit (RCMU)	Supported	Supported
DC surge protection	Type I+II (SPD) ^a	Type I+II (SPD) ^a
AC surge protection	Type II (SPD)	Type II (SPD)
Overvoltage category	II (DC)/III (AC)	II (DC)/III (AC)

Note a: The DC SPD complies with IEC/EN 61643-11 and IEC/EN 61643-31.

Display and Communication

Item	SUN2000-30K-MC0	SUN2000-40K-MC0
Display	LED indicators; WLAN+App	LED indicators; WLAN+App
RS485	Supported	Supported
Built-in WLAN	Supported	Supported
AC MBUS	Not supported	Not supported
WLAN-FE Dongle	Optional	Optional
4G Dongle	Optional	Optional
Optimizer	Supported	Supported

General Specifications

Item	SUN2000-30K-MC0	SUN2000-40K-MC0
Dimensions (W x H x D)	640 mm x 530 mm x 270 mm	640 mm x 530 mm x 270 mm
Net weight (including hanging kits)	45 kg	45 kg
Operating ambient temperature	-25°C to +60°C	-25°C to +60°C
Storage temperature	-40°C to +70°C	-40°C to +70°C
Cooling mode	Natural convection	Natural convection
Maximum operating altitude	4000 m (derated when the altitude is higher than 4000 m)	4000 m (derated when the altitude is higher than 4000 m)
Relative humidity	0%–100% RH	0%–100% RH
Input terminal	Amphenol Helios H4	Amphenol Helios H4
Output terminal	Waterproof terminal +OT/DT terminal	Waterproof terminal +OT/DT terminal
IP rating	IP66	IP66
Topology	Transformerless	Transformerless

NOTE

The SUN2000 complies with IEC 61000-3-12.

Wireless Communication Specifications

Item	SUN2000-30K-MC0	SUN2000-40K-MC0
Frequency	2400-2483.5 MHz	2400-2483.5 MHz
Protocols and standards	WLAN 802.11b/g/n	WLAN 802.11b/g/n
Bandwidth	20 MHz/40 MHz (optional)	20 MHz/40 MHz (optional)
Maximum transmit power	≤ 20 dBm EIRP	≤ 20 dBm EIRP

A Grid Codes

 NOTE

The grid codes are subject to change. The listed codes are for reference only.

No.	Grid Code	Description	SUN2000-30K-MC0	SUN2000-40K-MC0
1	IEC61727	IEC 61727 low-voltage grid-connection (50 Hz)	Support ed	Support ed
2	IEC61727-MV480	IEC 61727 medium-voltage grid-connection (50 Hz)	Support ed	Support ed
3	IEEE 1547-MV480	IEEE 1547-MV480	Support ed	Support ed
4	IEC61727-60Hz	IEC 61727 low-voltage grid-connection (60 Hz)	Support ed	Support ed
5	IEC61727-60Hz-MV480	IEC 61727 medium-voltage grid-connection (60 Hz)	Support ed	Support ed
6	VDE-AR-N4120-HV	VDE 4120 standard power grid	Support ed	Support ed
7	VDE-AR-N4120-HV480	VDE 4120 standard power grid	Support ed	Support ed
8	Fuel-Engine-Grid	Genset hybrid power grid	Support ed	Support ed
9	Fuel-Engine-Grid-60Hz	Genset hybrid power grid	Support ed	Support ed

No.	Grid Code	Description	SUN200 0-30K- MCO	SUN200 0-40K- MCO
10	Custom (50 Hz)	Reserved	Support ed	Support ed
11	Custom (60 Hz)	Reserved	Support ed	Support ed
12	Custom MV480 (50 Hz)	Reserved	Support ed	Support ed
13	Custom MV480 (60 Hz)	Reserved	Support ed	Support ed
14	VDE-AR-N-4105	Germany low- voltage power grid	Support ed	Support ed
15	BDEW-MV	Germany medium- voltage power grid	Support ed	Support ed
16	BDEW-MV480	Germany medium- voltage standard power grid	Support ed	Support ed
17	VDE-AR-N4110	Germany medium- voltage power grid (230 V)	Support ed	Support ed
18	VDE-AR-N4110-MV480	Germany medium- voltage standard power grid	Support ed	Support ed
19	UTE C 15-712-1(A)	France mainland power grid	Support ed	Support ed
20	UTE C 15-712-1(B)	France island power grid	Support ed	Support ed
21	UTE C 15-712-1(C)	France island power grid	Support ed	Support ed
22	UTE C 15-712-1-MV480	France island power grid	Support ed	Support ed
23	NC2022	New Caledonia power grid	Support ed	Support ed
24	VDE 0126-1-1-BU	Bulgaria power grid	Support ed	Support ed
25	VDE 0126-1-1-GR(A)	Greece mainland power grid	Support ed	Support ed
26	VDE 0126-1-1-GR(B)	Greece island power grid	Support ed	Support ed

No.	Grid Code	Description	SUN2000-30K-MCO	SUN2000-40K-MCO
27	G59-England	England 230 V power grid (I > 16 A)	Supported	Supported
28	G59-Scotland	Scotland 240 V power grid (I > 16 A)	Supported	Supported
29	G83-England	England 230 V power grid (I < 16 A)	Supported	Supported
30	G83-Scotland	Scotland 240 V power grid (I < 16 A)	Supported	Supported
31	G59-England-MV480	UK 480 V medium-voltage grid connection (I > 16 A)	Supported	Supported
32	G99-TYPEA-LV	UK G99-TYPEA-LV power grid	Supported	Supported
33	G99-TYPEB-LV	UK G99-TYPEB-LV power grid	Supported	Supported
34	G99-TYPEB-HV	UK G99-TYPEB-HV power grid	Supported	Supported
35	G99-TYPEB-HV-MV480	UK G99-TYPEB-HV medium-voltage power grid	Supported	Supported
36	G99-TYPEA-HV	UK G99-TYPEA-HV power grid	Supported	Supported
37	CEI0-21	Italy power grid	Supported	Supported
38	CEI0-16	Italy power grid	Supported	Supported
39	CEI0-16-MV480	Italy medium-voltage power grid	Supported	Supported
40	CEI0-21-MV480	Italy medium-voltage power grid	Supported	Supported
41	EN50438-CZ	Czech Republic power grid	Supported	Supported
42	CZECH-EN50549-LV230	Czech Republic power grid	Supported	Supported
43	RD1699/661	Spain low-voltage power grid	Supported	Supported

No.	Grid Code	Description	SUN200 0-30K- MCO	SUN200 0-40K- MCO
44	RD1699/661-MV480	Spain medium-voltage power grid	Support ed	Support ed
45	PO12.3-MV480	Spain medium-voltage power grid	Support ed	Support ed
46	PO12.3	Spain low-voltage power grid	Support ed	Support ed
47	NTS	Spain power grid	Support ed	Support ed
48	NTS-MV480	Spain medium-voltage power grid	Support ed	Support ed
49	EN50438-NL	Netherlands power grid	Support ed	Support ed
50	EN50438-NL-MV480	Netherlands medium-voltage power grid	Support ed	Support ed
51	C10/11	Belgium power grid	Support ed	Support ed
52	C11/C10-MV480	Belgium medium-voltage power grid	Support ed	Support ed
53	C10/11-MV400	Belgium medium-voltage power grid	Support ed	Support ed
54	TAI-PEA	Thailand grid-connection standard	Support ed	Support ed
55	TAI-MEA	Thailand grid-connection standard	Support ed	Support ed
56	TAI-PEA-MV480	Thailand medium-voltage grid-connection (PEA)	Support ed	Support ed
57	TAI-MEA-MV480	Thailand medium-voltage grid-connection (MEA)	Support ed	Support ed
58	EN50438-DK-MV480	Denmark medium-voltage grid-connection	Support ed	Support ed
59	DENMARK-EN50549-DK1-LV230	Denmark power grid	Support ed	Support ed

No.	Grid Code	Description	SUN2000-30K-MCO	SUN2000-40K-MCO
60	DENMARK-EN50549-DK2-LV230	Denmark power grid	Supported	Supported
61	EN50438-TR-MV480	Türkiye medium-voltage power grid	Supported	Supported
62	EN50438-TR	Türkiye low-voltage power grid	Supported	Supported
63	Philippines	Philippines low-voltage power grid	Supported	Supported
64	Philippines-MV480	Philippines medium-voltage power grid	Supported	Supported
65	NRS-097-2-1	South Africa standard power grid	Supported	Supported
66	NRS-097-2-1-MV480	South Africa medium-voltage standard power grid	Supported	Supported
67	SA_RPPs	South Africa low-voltage power grid	Supported	Supported
68	SA_RPPs-MV480	South Africa medium-voltage power grid	Supported	Supported
69	KOREA	South Korea power grid	Supported	Supported
70	KOREA-MV480	South Korea medium-voltage power grid	Supported	Supported
71	ANRE	Romania low-voltage power grid	Supported	Supported
72	ANRE-MV480	Romania medium-voltage power grid	Supported	Supported
73	ANRE-TYPEB	Romania power grid (type B)	Supported	Supported
74	ANRE-TYPEB-MV480	Romania power grid (type B)	Supported	Supported
75	EN50438_IE-MV480	Ireland medium-voltage power grid	Supported	Supported
76	EN50438_IE	Ireland low-voltage power grid	Supported	Supported

No.	Grid Code	Description	SUN2000-30K-MCO	SUN2000-40K-MCO
77	EN50549-LV	Ireland power grid	Supported	Supported
78	EN50549-MV480	Ireland medium-voltage power grid	Supported	Supported
79	EN50549-MV400	Ireland new standard power grid	Supported	Supported
80	Egypt ETEC	Egypt low-voltage power grid	Supported	Supported
81	Egypt ETEC-MV480	Egypt medium-voltage power grid	Supported	Supported
82	Jordan-Transmission	Jordan low-voltage power grid	Supported	Supported
83	Jordan-Transmission-MV480	Jordan medium-voltage power grid	Supported	Supported
84	NAMIBIA	Namibia power grid	Supported	Supported
85	NAMIBIA_MV480	Namibia power grid	Supported	Supported
86	ABNT NBR 16149	Brazil power grid	Not supported	Not supported
87	ABNT NBR 16149-MV480	Brazil medium-voltage power grid	Not supported	Not supported
88	INDIA	India low-voltage power grid	Supported	Supported
89	CEA	India CEA low-voltage power grid	Supported	Supported
90	CEA-MV480	India CEA medium-voltage power grid	Supported	Supported
91	ZAMBIA	Zambia low-voltage power grid	Supported	Supported
92	ZAMBIA-MV480	Zambia medium-voltage power grid	Supported	Supported
93	Chile	Chile low-voltage power grid	Supported	Supported

No.	Grid Code	Description	SUN200 0-30K- MCO	SUN200 0-40K- MCO
94	Chile-MV480	Chile medium-voltage power grid	Support ed	Support ed
95	Mexico-MV480	Mexico medium-voltage power grid	Support ed	Support ed
96	Malaysian	Malaysia low-voltage power grid	Support ed	Support ed
97	Malaysian-MV480	Malaysia medium-voltage power grid	Support ed	Support ed
98	KENYA_ETHIOPIA	Kenya low-voltage power grid and Ethiopia power grid	Support ed	Support ed
99	KENYA_ETHIOPIA-MV480	Kenya low-voltage power grid and Ethiopia medium-voltage power grid	Support ed	Support ed
100	NIGERIA	Nigeria low-voltage power grid	Support ed	Support ed
101	NIGERIA-MV480	Nigeria medium-voltage power grid	Support ed	Support ed
102	DUBAI	Dubai low-voltage power grid	Support ed	Support ed
103	DUBAI-MV480	Dubai medium-voltage power grid	Support ed	Support ed
104	Northern Ireland	Northern Ireland low-voltage power grid	Support ed	Support ed
105	Northern Ireland-MV480	Northern Ireland medium-voltage power grid	Support ed	Support ed
106	Cameroon	Cameroon low-voltage power grid	Support ed	Support ed
107	Cameroon-MV480	Cameroon medium-voltage power grid	Support ed	Support ed
108	Jordan-Distribution	Jordan power distribution network low-voltage power grid	Support ed	Support ed

No.	Grid Code	Description	SUN2000-30K-MCO	SUN2000-40K-MCO
109	Jordan-Distribution-MV480	Jordan power distribution network medium-voltage power grid	Support ed	Support ed
110	Jordan-Transmission-HV	Jordan high-voltage power grid	Support ed	Support ed
111	Jordan-Transmission-HV480	Jordan high-voltage power grid	Support ed	Support ed
112	LEBANON	Lebanon low-voltage power grid	Support ed	Support ed
113	LEBANON-MV480	Lebanon medium-voltage power grid	Support ed	Support ed
114	TUNISIA	Tunisia power grid	Support ed	Support ed
115	TUNISIA-MV480	Tunisia medium-voltage power grid	Support ed	Support ed
116	SAUDI	Saudi Arabia power grid	Support ed	Support ed
117	SAUDI-MV480	Saudi Arabia power grid	Support ed	Support ed
118	Ghana-MV480	Ghana medium-voltage power grid	Support ed	Support ed
119	Israel	Israel power grid	Support ed	Support ed
120	Israel-MV480	Israel power grid	Support ed	Support ed
121	Israel-MV400	Israel medium-voltage power grid	Support ed	Support ed
122	Chile-PMGD	Chile PMGD power grid	Support ed	Support ed
123	Chile-PMGD-MV480	Chile PMGD power grid	Support ed	Support ed
124	Chile-Net_Billing	Chile Net Billing power grid	Support ed	Support ed
125	Vietnam	Vietnam power grid	Support ed	Support ed

No.	Grid Code	Description	SUN2000-30K-MCO	SUN2000-40K-MCO
126	Vietnam-MV480	Vietnam power grid	Support ed	Support ed
127	TAIPOWER	Taiwan Power low-voltage power grid	Support ed	Support ed
128	TAIPOWER-MV480	Taiwan Power medium-voltage power grid (480 V)	Support ed	Support ed
129	ARGENTINA-MV480	Argentina medium-voltage power grid	Support ed	Support ed
130	Oman	Oman low-voltage power grid	Support ed	Support ed
131	Oman-MV480	Oman medium-voltage power grid	Support ed	Support ed
132	Kuwait	Kuwait low-voltage power grid	Support ed	Support ed
133	Kuwait-MV480	Kuwait medium-voltage power grid	Support ed	Support ed
134	Bangladesh	Bangladesh low-voltage power grid	Support ed	Support ed
135	Bangladesh-MV480	Bangladesh medium-voltage power grid	Support ed	Support ed
136	Bahrain	Bahrain low-voltage power grid	Support ed	Support ed
137	Bahrain-MV480	Bahrain medium-voltage power grid	Support ed	Support ed
138	ARGENTINA	Argentina power grid	Support ed	Support ed
139	Mauritius	Mauritius power grid	Support ed	Support ed
140	Mauritius-MV480	Mauritius medium-voltage power grid	Support ed	Support ed
141	EN50438-SE	Sweden power grid	Support ed	Support ed
142	Austria	Austria power grid	Support ed	Support ed
143	Austria-MV480	Austria medium-voltage power grid	Support ed	Support ed

No.	Grid Code	Description	SUN2000-30K-MCO	SUN2000-40K-MCO
144	AUSTRIA-TYPEB-LV400	Austria power grid	Supported	Supported
145	AUSTRIA-TYPEB-LV480	Austria power grid	Supported	Supported
146	AUSTRIA-TYPEB-MV400	Austria power grid	Supported	Supported
147	AUSTRIA-TYPEB-MV480	Austria power grid	Supported	Supported
148	SINGAPORE	Singapore low-voltage power grid	Supported	Supported
149	SINGAPORE-MV480	Singapore medium-voltage power grid	Supported	Supported
150	HONGKONG	Hong Kong low-voltage power grid	Supported	Supported
151	HONGKONG-MV480	Hong Kong medium-voltage power grid	Supported	Supported
152	EN50549-PL	Poland power grid	Supported	Supported
153	SWITZERLAND-NA/EEA:2020-LV230	Switzerland power grid	Supported	Supported
154	FINLAND-EN50549-LV230	Finland power grid	Supported	Supported
155	BRAZIL-P140-LV220	Brazil P140 power grid	Not supported	Not supported
156	BRAZIL-P140-480	Brazil P140 power grid	Not supported	Not supported
157	FRANCE-EN50549-230	France FD C11-519-11	Supported	Supported
158	GREG030	Colombia power grid	Supported	Supported
159	GREG030-MV480	Colombia power grid	Supported	Supported
160	CZECH-EN50549-B1/B2-230	Czech Republic power grid (B1/B2)	Supported	Supported

No.	Grid Code	Description	SUN200-30K-MCO	SUN200-40K-MCO
161	FRANCE-EN50549-519/12-230	France FD C11-519-12	Supported	Supported

B Connecting to a Device on the App (the Device Supports WLAN)

NOTICE

- When directly connecting your phone to a device, ensure that your phone is within the WLAN coverage of the device.

Step 1 Start device commissioning.

Figure B-1 Method 1: mobile phone connected to the Internet

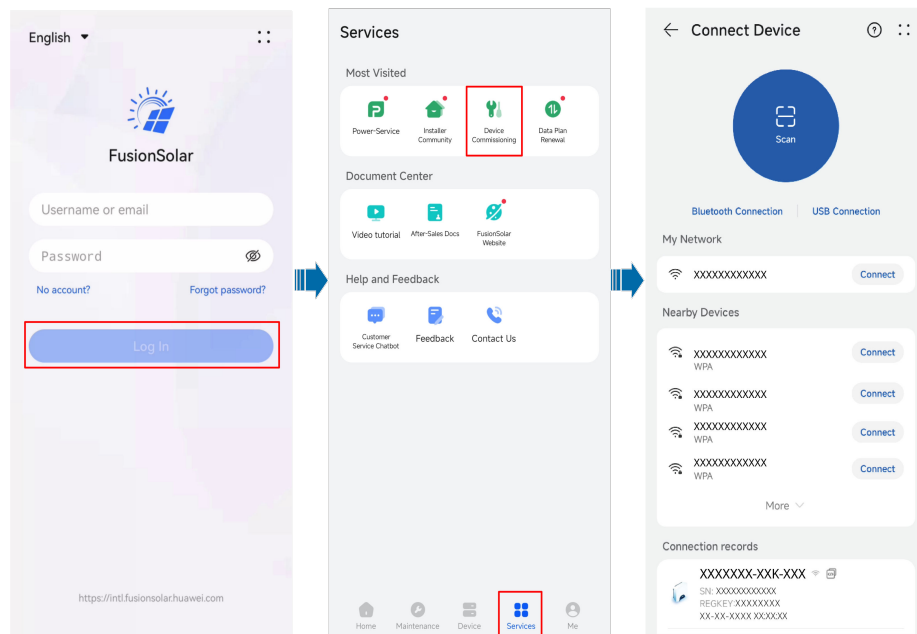
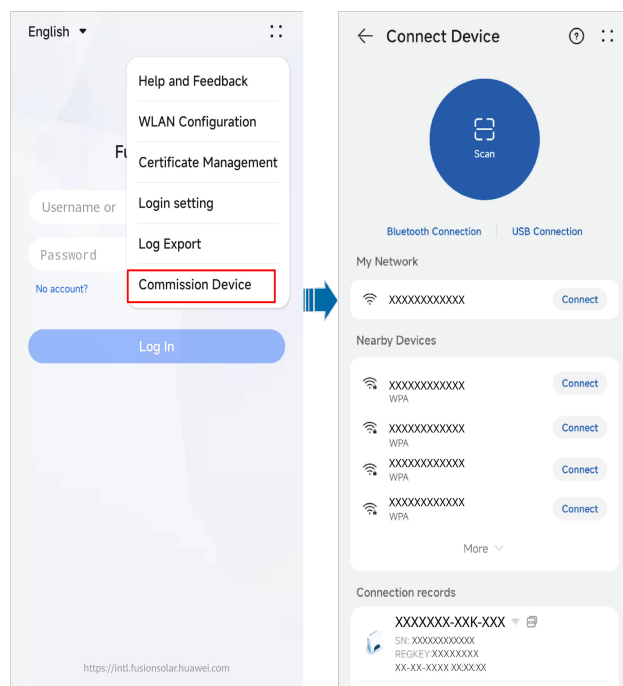

Figure B-2 Method 2: mobile phone not connected to the Internet**Step 2** Connect to the device WLAN.

Tap **Scan**. On the scanning screen, align the QR code of the device WLAN with the scanning box to automatically scan and connect to the device.

NOTE

- The WLAN name of a device consists of "Device name-Device SN." (The last six digits of the WLAN names of some devices are the same as the last six digits of the device SNs.)
- For the first connection, log in with the initial password. You can obtain the initial WLAN password from the label on the device.
- Ensure account security by changing the password periodically. Your password might be stolen or cracked if it is left unchanged for extended periods. If a password is lost, the device cannot be accessed. In these cases, the Company shall not be liable for any loss.
- If the login screen is not displayed after you scan the QR code, check whether your phone is correctly connected to the device WLAN. If not, manually select and connect to the WLAN.
- If **This WLAN network has no Internet access. Connect anyway?** message is displayed when you connect to the built-in WLAN, tap **CONNECT**. Otherwise, you cannot log in to the system. The actual UI and messages may vary with mobile phones.

Step 3 Log in to the device commissioning screen as **Installer**.

NOTICE

- After completing the deployment settings, the installer shall remind the owner to access the local commissioning screen of the device and set the login password of the owner account as prompted.
 - Ensure account security by changing the password periodically. Your password might be stolen or cracked if it is left unchanged for extended periods. If a password is lost, the device cannot be accessed. In these cases, the Company shall not be liable for any loss.
-

----End

C Crimping an OT or DT Terminal

Requirements for the OT or DT Terminal

- If a copper cable is used, use copper wiring terminals.
- If a copper-clad aluminum cable is used, use copper wiring terminals.
- If an aluminum alloy cable is used, use copper-aluminum transition wiring terminals, or aluminum wiring terminals along with copper-aluminum transition spacers.

NOTICE

- Do not connect aluminum wiring terminals to the AC terminal block. Otherwise the electrochemical corrosion will occur and affect the reliability of cable connections.
 - Comply with the IEC61238-1 requirements when using copper-aluminum transition wiring terminals, or aluminum wiring terminals along with copper-aluminum transition spacers.
 - If copper-aluminum transition spacers are used, pay attention to the front and rear sides. Ensure that the aluminum sides of spacers are in contact with aluminum wiring terminals, and copper sides of spacers are in contact with the AC terminal block.
-

Figure C-1 Requirements for the OT/DT terminal

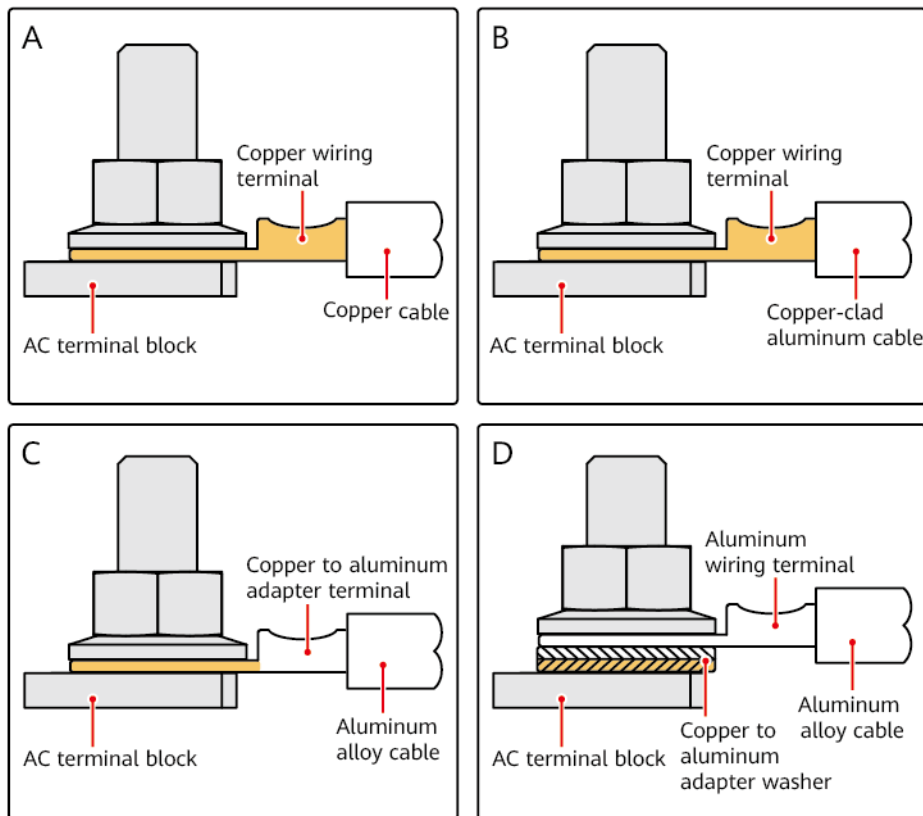

IS03H00062

Crimping an OT or DT Terminal

NOTICE

- Pay attention not to scratch the core wire when stripping a cable.
- The cavity formed after the conductor crimp strip of the OT or DT terminal is crimped must wrap the core wires completely. The core wires must contact the OT or DT terminal closely.
- Wrap the wire crimping area with a heat shrink tubing or PVC insulation tape. The heat shrink tubing is used as an example.
- When using a heat gun, protect devices from being scorched.

Figure C-2 Crimping an OT terminal

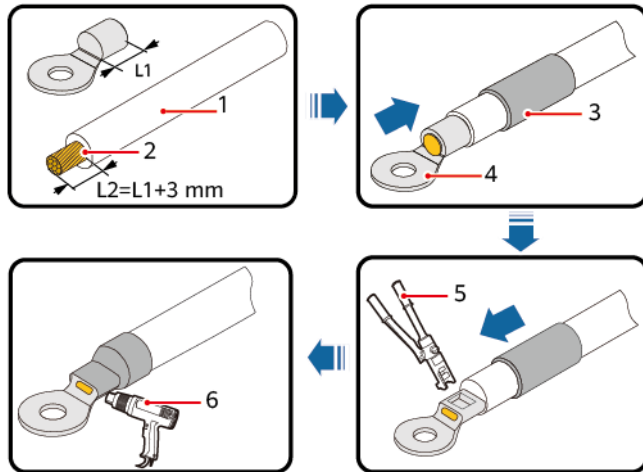

(1) Cable

(2) Core

(3) Heat shrink tubing

(4) OT terminal

(5) Hydraulic pliers

(6) Heat gun

Figure C-3 Crimping a DT terminal

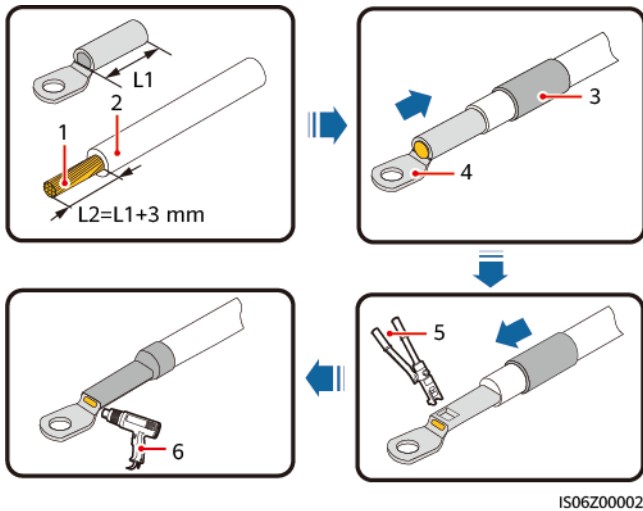

(1) Core

(2) Cable

(3) Heat shrink tubing

(4) DT terminal

(5) Hydraulic pliers

(6) Heat gun

D Rapid Shutdown

If optimizers are configured for all PV modules connected to the inverter, the PV system can perform a rapid shutdown to decrease the output voltage to below 30 V within 30s. The rapid shutdown function is not supported if optimizers are configured for some PV modules.

Perform the following steps to trigger a rapid shutdown:

- Method 1 (recommended): Turn off the AC switch between the inverter and the power grid (disconnect the voltages of all PV strings connected to the inverter under the AC switch).
- Method 2: Set the **DC SWITCH** of the inverter to **OFF** to trigger a rapid shutdown. The inverter shuts down immediately. (Turning off all external switches on the DC side of an inverter can trigger a rapid shutdown, and only the PV strings connected to the inverter are de-energized. Turning off only some external switches cannot trigger a rapid shutdown, and the PV strings may be energized.)
- Method 3: To use the DI rapid shutdown function, connect the switch to DIN5 (pin 15) and GND (pin 13) at the communications terminal of the inverter. The switch shall be closed by default. When the switch is opened, rapid shutdown is triggered. The distance between the switch and the farthest inverter must be less than or equal to 10 m.

NOTE

Log in to the local commissioning screen as **Installer**, choose **Set > Feature parameters > Dry contact function**, and set **Dry contact function** to **DI rapid shutdown**.

- Method 4: If **AFCI** is set to **Enable**, the inverter automatically performs arc fault detection and triggers a rapid shutdown when AFCI lock protection is implemented.

NOTE

Log in to the local commissioning screen as **Installer**, choose **Set > Feature parameters**, and set **AFCI** to **Enable**.

E Setting the Physical Layout of Smart PV Optimizers

NOTE





- If Smart PV Optimizers are configured for PV strings, ensure that the Smart PV Optimizers have been successfully connected to the inverter before performing other operations.
- Check that the SN labels of Smart PV Optimizers are correctly attached to the physical layout template.
- Take and save a photo of the physical layout template. Keep your phone parallel to the template and take a photo in landscape mode. Ensure that the four positioning points at the corners are in the frame and that each QR code is attached within the frame.
- For details about the physical layout of the optimizers, see [FusionSolar Physical Layout User Guide](#).

F Smart I-V Curve Diagnosis

For details, see [iMaster NetEco V600R023C00 Smart I-V Curve Diagnosis User Manual](#).

G Resetting a Password

G.1 Power-On and Power-Off

- Step 1** Check that the AC and DC sides of the inverter are both powered on, and indicators  and  are steady green or blinking slowly for more than 3 minutes.
- Step 2** Turn off the AC switch, set the **DC SWITCH** on the inverter to **OFF**, and wait until all LED indicators on the inverter panel are off.
- Step 3** Complete the following operations within 4 minutes:
1. Turn on the AC switch and wait about 90s or until the inverter indicator  blinks.
 2. Turn off the AC switch and wait about 30s or until all LED indicators on the inverter panel are off.
 3. Turn on the AC switch and wait about 30s or until all LED indicators on the inverter panel blink and then are off after about 30s.
 4. Turn off the AC switch and wait about 30s or until all LED indicators on the inverter panel are off.
 5. Turn on the AC switch and wait about 30s or until all LED indicators on the inverter panel blink and then are off after about 30s.
- Step 4** Wait until the three green LEDs on the inverter panel blink fast and then the three red LEDs blink fast, which indicates that the password is restored.
- Step 5** Reset the password within 10 minutes. (If no operation is performed within 10 minutes, the login password of the inverter remains unchanged.)
1. Wait until the  indicator blinks.
 2. Connect to the app using the initial WLAN hotspot name (SSID) and initial password (PSW), which can be obtained from the label on the side of the inverter.
 3. On the login screen, set a new password and log in to the app.

----End

NOTICE

You are advised to reset the password in the morning or at night when the solar irradiance is low.

G.2 Resetting the Password After Connecting to the Device and Obtaining the Verification Code

Prerequisites

1. The inverter is networked with the SmartLogger5000B, SmartMGC5000B, or Smart Dongle.
2. The inverter is connected to the FusionSolar Smart PV Management System (SmartPVMS).
3. The inverter, SmartLogger5000B, SmartMGC5000B, or Smart Dongle, and app are of the latest versions.

Procedure

1. Log in to the FusionSolar app and choose **Services > Device Commissioning**.
2. Connect to the WLAN of the inverter and access the **Log in** screen.

NOTE

Connect to the WLAN of the inverter as follows:

- Tap **Scan**. On the scanning screen, align the QR code of the device WLAN with the scanning box to automatically scan and connect to the device.
 - If the login screen is not displayed after you scan the QR code, check whether your phone is correctly connected to the device WLAN. If not, manually select and connect to the WLAN.
3. On the **Log in** screen, select the user role whose password needs to be reset and tap **Forgot password?**
 4. On the **Reset Password** screen, choose **Get Code**.

NOTE

If you fail to obtain a verification code, reset the password by operating the AC switch and "DC SWITCH" of the inverter. For details, see section "Resetting a Password" in the inverter user manual.

5. Enter the login password of the FusionSolar app to obtain a verification code as prompted.

NOTE

The verification code is valid for 30 minutes. Enter it in the text box within the validity period.

6. On the **Reset Password** screen, enter the verification code and tap **OK**.

NOTE

The verification code will expire after 10 failed attempts. In that case, you need to obtain a new verification code.

7. On the **Log In** screen, set a new password.

 **NOTE**

Set a new password to log in to the device again within 10 minutes.

Figure G-1 Login screen

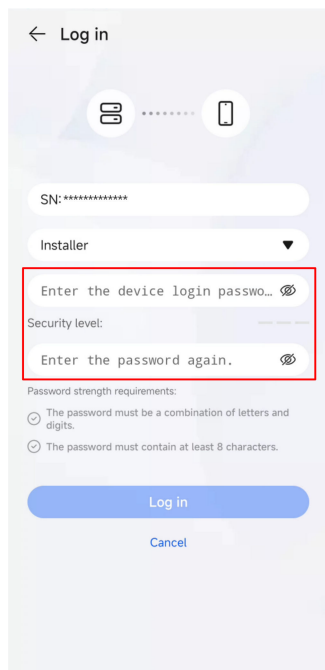

More Instructions

If the message in the following figure is displayed, tap **OK** to return to the device connection screen, reconnect to the device WLAN, access the **Reset Password** screen again, and enter the verification code.

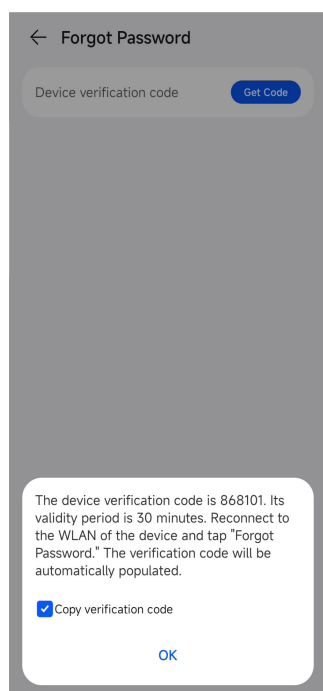

G.3 Resetting the Password After Obtaining the Verification Code and Connecting to the Device

Prerequisites

1. The inverter is networked with the SmartLogger5000B, SmartMGC5000B, or Smart Dongle.
2. The inverter is connected to the FusionSolar Smart PV Management System (SmartPVMS).
3. The inverter, SmartLogger5000B, SmartMGC5000B, or Smart Dongle, and app are of the latest versions.

Procedure

1. Log in to the FusionSolar app and select the target plant on the home screen.
2. On the **Device** screen, choose **Inverter > : : > O&M Authorization > Device verification code**.
3. On the **Device verification code** screen, choose **Get Code**.

NOTE

If you fail to obtain a verification code, reset the password by operating the AC switch and "DC SWITCH" of the inverter. For details, see section "Resetting a Password" in the inverter user manual.

4. Enter the login password of the FusionSolar app to obtain a verification code as prompted.

NOTE

The verification code is valid for 30 minutes. Enter it in the text box within the validity period.

5. Select options as prompted and connect to the WLAN of the inverter.

NOTE

Connect to the WLAN of the inverter as follows:

- Tap **Scan**. On the scanning screen, align the QR code of the device WLAN with the scanning box to automatically scan and connect to the device.
- If the login screen is not displayed after you scan the QR code, check whether your phone is correctly connected to the device WLAN. If not, manually select and connect to the WLAN.

6. On the **Log in** screen, select the user role whose password needs to be reset and tap **Forgot password?**
7. On the **Reset Password** screen, enter the verification code and tap **OK**.

NOTE

The verification code will expire after 10 failed attempts. In that case, you need to obtain a new verification code.

8. On the **Log In** screen, set a new password.

 **NOTE**

Set a new password to log in to the device again within 10 minutes.

Figure G-2 Login screen

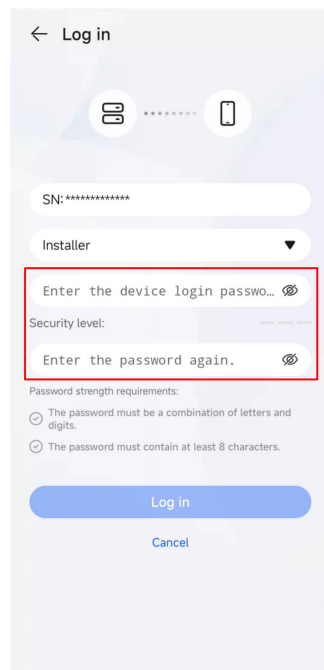

G.4 Resetting the Password on the SmartLogger WebUI

Prerequisites

1. The inverter is not connected to the FusionSolar SmartPVMS.
2. The inverter is networked with the SmartLogger5000B or SmartMGC5000B.
3. The inverter, SmartLogger5000B or SmartMGC5000B, and app are of the latest versions.

Procedure

1. Log in to the SmartLogger WebUI and choose **Maintenance > Security Management > Password Reset**.
2. Select the inverter for which the password needs to be reset.
3. Click **Reset** to obtain a verification code.

 **NOTE**

The verification code is valid for 4 hours. Enter it in the text box within the validity period.

4. Log in to the FusionSolar app and choose **Services > Device Commissioning**.
5. Connect to the WLAN of the inverter and access the **Log in** screen.

 **NOTE**

Connect to the WLAN of the inverter as follows:

- Tap **Scan**. On the scanning screen, align the QR code of the device WLAN with the scanning box to automatically scan and connect to the device.
 - If the login screen is not displayed after you scan the QR code, check whether your phone is correctly connected to the device WLAN. If not, manually select and connect to the WLAN.
6. On the **Log in** screen, select the user role whose password needs to be reset and tap **Forgot password?**.
 7. On the **Reset Password** screen, enter the verification code and tap **OK**.

 **NOTE**

The verification code will expire after 10 failed attempts. In that case, you need to obtain a new verification code.

8. Connect to the WLAN of the inverter and access the **Log in** screen.

 **NOTE**

Connect to the WLAN of the inverter as follows:

- Tap **Scan**. On the scanning screen, align the QR code of the device WLAN with the scanning box to automatically scan and connect to the device.
 - If the login screen is not displayed after you scan the QR code, check whether your phone is correctly connected to the device WLAN. If not, manually select and connect to the WLAN.
9. On the **Log In** screen, set a new password.

 **NOTE**

Set a new password to log in to the device again within 10 minutes.

Figure G-3 Login screen

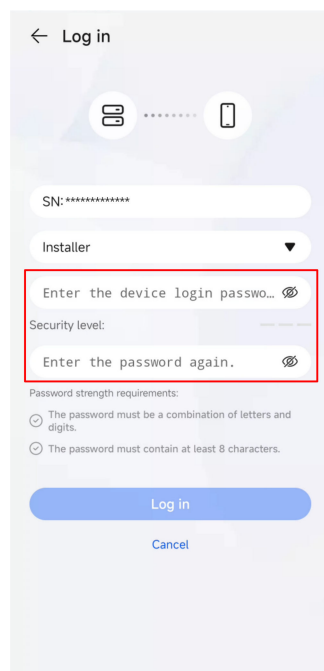

H Contact Information

If you have any questions about this product, please contact us.



<https://digitalpower.huawei.com>

Path: **About Us > Contact Us > Service Hotlines**

To ensure faster and better services, we kindly request your assistance in providing the following information:

- Model
- Serial number (SN)
- Software version
- Alarm ID or name
- Brief description of the fault symptom

 **NOTE**

EU Representative Information: Huawei Technologies Hungary Kft.
Add.: HU-1133 Budapest, Váci út 116-118., 1. Building, 6. floor.
Email: hungary.reception@huawei.com

Digital Power Customer Service



<https://digitalpower.huawei.com/robotchat/>

J Certificate Management and Maintenance

J.1 Initial Certificate Risk Disclaimer

Huawei's initial certificates are mandatory identity credentials for Huawei devices before delivery. The disclaimer statements for using the certificates are as follows:

1. Huawei's initial certificates are used only in the deployment phase, for establishing initial security channels between devices and the customer's network. Huawei does not promise or guarantee the security of the initial certificates.
2. Customers shall bear consequences of all security risks and security incidents arising from using Huawei's initial certificates as service certificates.
3. The validity of Huawei's initial certificates starts from the manufacturing date and ends in December 2099 for products delivered after 2024.
4. Services using an initial certificate will be interrupted when the certificate expires.
5. It is recommended that customers deploy a PKI system to issue certificates for devices and software on the live network and manage the lifecycle of the certificates. To ensure security, certificates with short validity periods are recommended.

J.2 Application Scenarios of Initial Certificates

Table J-1 Application scenarios of initial certificates

File Path and Name	Scenario	Replacement
f:/app_ca.crt (Root certificate)	When the inverter connects to the mobile phone app through Modbus-TCP, one-way certificate authentication is performed.	Log in to the mobile app and choose Set > Communication configuration > Certificate management > App communication certificate to replace the certificate.
f:/app_tomcat_client.crt (Local certificate)		
f:/app_tomcat_client.key (Private key file)		

K Acronyms and Abbreviations

A

AFCI arc-fault circuit
interrupter

L

LED light emitting diode

M

MBUS monitoring bus

MPP maximum power point

MPPT maximum power point
tracking

P

PE protective earthing

PID potential induced
degradation

PV photovoltaic

R

RCD residual current device

S

SPD surge protective device