

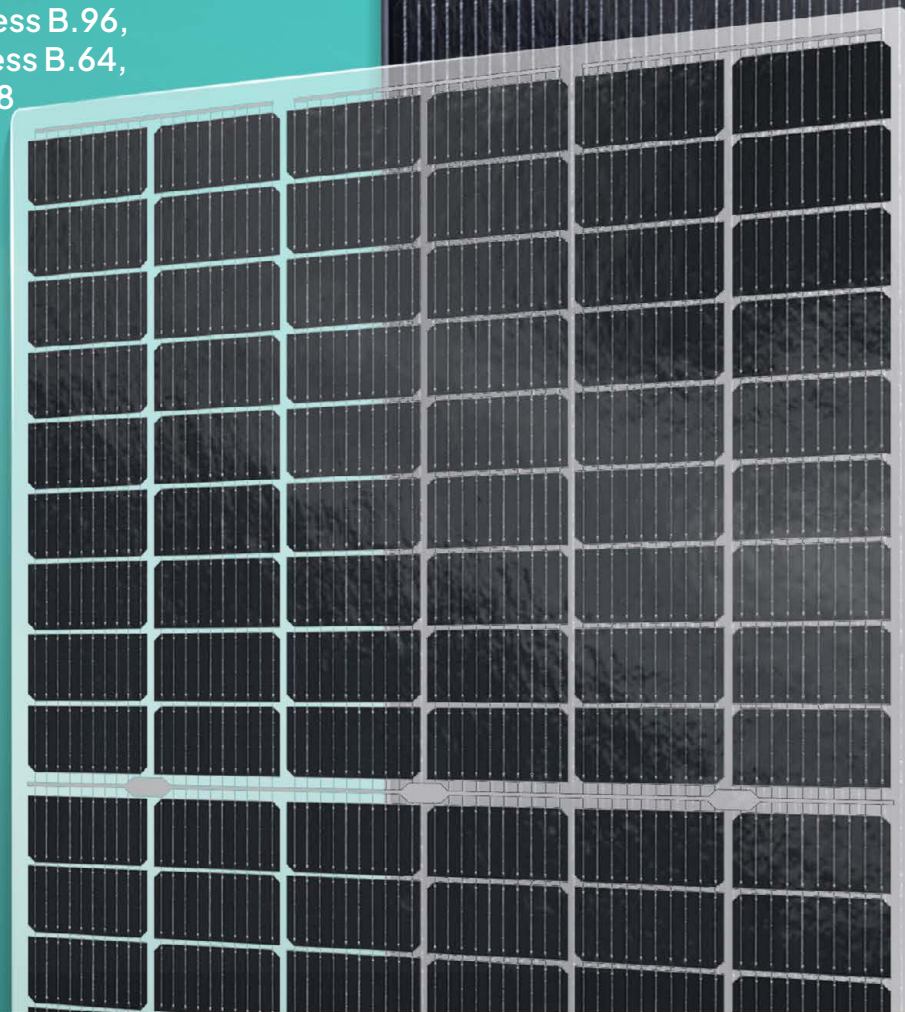

SOLID Installation manual

BLACKSTAR B.96,
 BLACKSTAR Satin B.96,
 SOLID Semi-clear Framed B.96
 SOLID Semi-clear Framed B.96 35(40) mm,
 SOLID Black Framed B.96 35(40) mm,
 SOLID Satin Framed B.96 35(40) mm,
 SOLID Agro Framed B.64 35(40) mm,
 SOLID Semi-clear Frameless B.96,
 SOLID Black Frameless B.96,
 SOLID Satin Frameless B.96,
 SOLID Agro Frameless B.64,
 SOLID Magnus B.108



Deutsches
Institut
für
Bautechnik

DIBt



**Congratulations on choosing
sustainable Solar Modules for
your home.**

Installation manual

GENERAL REQUIREMENTS



Please read this guide entirely before the installation.

The purpose of this document is to provide minimum requirements and recommendations for safe and successful installation of SoliTek PV modules.

This document also contains requirements necessary to retain SoliTek PV module compliance with IEC 61215, IEC 61730, UL 61730 standards.

This guide contains basic information regarding JSC "SoliTek Cells" SOLID series photovoltaic modules, their installation and safe handling. All instructions should be read and understood before attempting installation. If there are any questions, please contact your dealer or JSC "SoliTek Cells" for further information.

This documentation refers to the PV-modules themselves and is not meant to be a complete installation manual for personnel not specifically trained to PV-modules. It serves as a general but strictly mandatory to the Installer reference. Infringement or inaccurate observance of any clause of this documentation voids the warranty.

The installer must understand and follow all applicable local, state, and federal regulations and standards for building construction, electrical design, fire, and safety, and must check with local authorities to determine applicable permitting requirements before attempting to install or maintain PV modules and should become familiar with the mechanical and electrical requirements for photovoltaic systems.

Failure of follow instructions in this guide may damage system components, endanger personnel, damage property, or invalidate the panel warranty.

Roof-top PV systems should only be installed on dwellings that have been formally analyzed for structural integrity and confirmed to be capable of handling the additional weighted load of PV system components, including PV modules, by a certified building specialist or engineer.

For your safety, do not attempt to work on a rooftop until safety precautions have been identified and taken, including without limitation fall protection measures, ladders or stairways, and personal protective equipment (PPE).

For your safety, do not install or handle PV modules under adverse conditions, including without limitation strong or gusty winds, and wet or frosted roof surfaces.

The flat-plate PV module construction consists of a laminated assembly of solar cells encapsulated within an insulating material within two glass sheets.

Keep this documentation in a safe place for future reference.

Do not attempt to disassemble the module, and do not remove any attached nameplates or components! Doing so will void the warranty.

CONTENT

01	HANDLING & APPLICATION	6
1.1	Handling	6
1.2	Application	6
02	ELECTRICAL INSTALLATION	7
2.1	Safety	7
2.2	Configuration	8
2.3	Overcurrent protection device (OCPD)	9
2.4	Cable & wiring	9
2.5	Grounding	10
	Framed type modules grounding	10
	Frameless type module grounding	11
2.6	Connectors	11
2.7	Bypass diodes	11
03	MECHANICAL MOUNTING	12
3.1	General requirements	12
3.2	Mounting with clamps	13
3.3	SOLID Black, Semi-clear, Satin, Agro Frameless	14
3.4	BLACKSTAR, SOLID Black 35(40) mm, SOLID Semi-clear 35(40) mm, SOLID Satin 35(40) mm, SOLID Agro 35(40) mm, Magnus Framed	15
3.5	Position of the junction box	20
04	MAINTENANCE & SPECIFICATIONS	21
4.1	Maintenance	21
4.2	Specifications	22
05	DISCLAIMER OF LIABILITY	25

Handling & Application

1.1 | HANDLING

SoliTek PV modules must be transported in the supplied packaging only and kept in the packaging until they are ready to be installed. Protect pallets against movement and exposure to damage during transportation. Secure pallets from falling over. Do not exceed the maximum height of pallets to be stacked, as indicated on the pallet packaging. Store pallets in a cool and dry location until the PV modules are ready to be unpackaged.

SoliTek PV modules are heavy and should be handled with care. Never use the junction box or cables as a grip. Do not exert mechanical stress on the cables. Never step on PV modules or drop or place heavy objects on them. Be careful when placing PV modules on hard surfaces and secure them from falling. Broken glass can result in personal injury. PV modules with broken glass cannot be repaired and must not be used. Broken or damaged PV modules must be handled carefully and disposed of properly.

1.2 | APPLICATION

Restrictions

SoliTek PV modules must be mounted on appropriate mounting structures positioned on suitable buildings, the ground, or other structures suitable for PV modules (e.g. carports, building facades or PV trackers). PV modules must not be mounted on moving vehicles of any kind. Modules must not be installed in locations where they could be submerged in water. Do not install modules above 2000 m (6561 ft) altitude above sea level

Artificially concentrated light must not be directed on SoliTek PV modules.

Recommendations

SoliTek recommends that PV modules be mounted at a minimum tilt angle of 10 degrees to allow for proper self-cleaning from rain.

Partial or complete shading of a PV module or modules can significantly reduce system performance. SoliTek recommends minimizing the amount of shade throughout the year to increase the amount of energy produced by the PV modules.

High system voltages could be induced in the event of an indirect lightning strike, which could cause damage to PV system components. The open area of wire loops should be minimized; in order to reduce the risk of lightning induced voltage surges.

Better module ventilation and shorter connection cables increase electrical energy production.

For bifacial modules:

It is recommended to increase PV panel height from the ground so that more light can travel beneath the module and then reflect

The bifacial gain increases significantly if modules are installed above white (high albedo value), light reflecting surfaces.

Electrical installation

2.1 | SAFETY

PV modules can produce current and voltage when exposed to light of any intensity. Electrical current increases with higher light intensity. DC voltage of 50 Volts or higher is potentially lethal. Contacting the live circuitry of a PV system operating under light can result in lethal electric shock.

De-energize PV modules by removing them entirely from light or by covering their front surface with an opaque material. Regard the safety regulations for live electrical equipment when working with modules that are exposed to any light. Use insulated tools and do not wear metallic jewelry while working with PV modules.

In order to avoid arcing and electrical shock, do not disconnect electrical connections under load. Faulty connections can also result in arcing and electrical shock. Keep connectors dry and clean and ensure that they are in proper working condition. Never insert metallic objects into the connectors or modify them in any way in order to secure an electrical connection.



Do not touch or handle PV modules with broken glass unless the PV modules are first disconnected, and you are wearing proper PPE. Avoid handling PV modules when they are wet unless cleaning the PV modules as directed in this manual. Never touch electrical connections that are wet without protecting yourself with insulated gloves.

The modules are qualified for Class of protection against electrical shock Class II, in accordance with clause 4 of IEC 61730-1:2016, which can be used in systems operating at > 50 VDC or >240 W, where general contact access is anticipated and modules qualified for safety through UL 61730 within this application class are considered to meet the requirements of Safety Class II.

Installing solar photovoltaic systems requires specialized skills and knowledge. It should be performed only by qualified and specially instructed personnel. The installer assumes all risk of injury, including risk of electric shock.

Use only equipment, connectors, wiring and mounting hardware specifically designed for use in a photovoltaic system.

Before any manipulation at an installed PV plant, switch it off first on AC-side after on DC-side of the inverter or the charge controller.

When disconnecting wires connected to a photovoltaic module that is exposed to light, an electric arc may occur. Arcs can cause burns, start fires, or otherwise create safety (up to lethal electric shock) problems.

Check for remaining voltage before starting and observe the local safety relevant regulations for such working conditions.

Under normal conditions, a photovoltaic module can produce more current and/or voltage (here: 30V DC) than reported at standard test conditions.

Contact with a DC voltage of 30 V or more is potentially hazardous. Exercise caution when wiring or handling modules exposed to sunlight.

Only connect modules with the same rated output current in series. If modules are connected in series, the total voltage is equal to the sum of the individual module voltages.

Only connect modules or series combinations of modules with the same voltage in parallel. If modules are connected in parallel, the total current is equal to the sum of individual module or series combination currents.

Always use the same type of module within a particular photovoltaic system.

If the sum of short circuit currents of the parallel connected modules passes over the reverse current string diodes or fuses have to be used in each string of modules connected in parallel. These string diodes or fuses have to be qualified for the maximum expected current and voltage. The fuse rating value is also corresponding to the maximum reverse current that a module can withstand. The reverse current value can be found on the product label, in the product datasheet or chapter 8 of installation manual. Observe the instructions and safety precautions for all other components used in the system, including wiring and cables, connectors, DC-breakers, inverters, etc.

Use appropriate safety equipment (insulated tools, dielectric gloves, shoes and etc.) approved for use on electrical installations.

2.2 | CONFIGURATION

Under normal conditions, a photovoltaic module is likely to experience conditions that produce more current and/or voltage than reported at Standard Test Conditions (STC: 1000 W/m², AM1.5, and 25°C/77°F cell temperature) or Bifacial nominal power index (BNPI front irradiance 1000 W/m², back irradiance 135 W/m² AM1.5, and 25°C/77°F cell temperature). The short-circuit current (ISC) should be multiplied by a factor of 1.25 and the open-circuit voltage (VOC) should be multiplied by a factor of up to 1.25 based on the lowest and highest ambient temperature recorded for the installation location when determining component voltage ratings, conductor current ratings, fuse sizes, and size of controls connected to the PV output.

Voltages are additive when PV modules are connected directly in series, and module currents are additive when PV modules are connected directly in parallel. PV modules with different electrical characteristics must not be connected directly in series. The use of suitable third-party electronic devices connected to PV modules may enable different electrical connections and must be installed according to the manufacturer's specified instructions.

The maximum voltage of serial interconnection of the modules must be less than the maximum certified module's system voltage. Also, the maximum input voltage of the inverter and of the other electrical devices in the system must be taken into account. The open circuit voltage of the array string needs to be calculated at the lowest expected ambient temperature for the location. The maximal system voltage for module is indicated in the modules datasheet.

Accordingly, for BLACKSTAR, SOLID or MAGNUS series modules, the values of ISC and VOC under STC or BNPI marked on this module should be multiplied by a factor of 1,25 when determining component voltage ratings, conductor current ratings, fuse sizes, and size of controls connected to the PV output. In the USA, refer to Section 690-8 of the National Electrical Code (NEC) for an additional multiplying factor of 125 percent (80 percent de-rating) which may be applicable.

2.3 | OVERCURRENT PROTECTION DEVICE (OCPD)

When the potential reverse current of a PV string exceeds the rated SoliTek PV module series fuse rating (values indicated at the module datasheet) an overcurrent protection device (OCPD) must be used. An overcurrent protection device is required for each series string if more than two series are connected in parallel. In this case, it is needed to use one fuse per string rated at 1.25 x I_{sc} or higher (I_{sc} is the PV module's short circuit current at STC). A PV fuse on each PV string will protect the PV modules and conductors from overcurrent faults and help minimize any safety hazards. The PV fuse will also isolate the faulted PV string so the balance of the PV system can continue to generate electricity.

- Fuse amp rating $\geq 1.25 \times I_{sc}$

Select next higher standard rating at the catalogue of available PV Fuses.

I_{sc} = Short-circuit current of one module at Standard Test Conditions (STC).

Considering the values of I_{sc} of SoliTek modules, the right value of the PV Fuses to be used at the installation is 30 A. SoliTek recommends using PV fuses in both the positive and negative conductors.

2.4 | CABLE & WIRING

SoliTek PV modules are provided with two standard, sunlight resistant output cables that are terminated with PV connectors ready for most installations. The positive (+) terminal has a male connector while the negative (-) terminal has a female connector. The module wiring is intended for series connections (i.e., male (+) to female (-) interconnections) but can also be used to connect suitable third-party electrical devices that may have alternative wiring configurations so long as the manufacturer's instructions are followed.

Use field wiring with suitable cross-sectional areas that are approved for use at the maximum short-circuit current of the PV module. All wiring must be double insulated, cross-linked cables with a minimum rating of 1,8 kV (over 1500 V voltage) and minimum rated temperature of 90 °C (190 °F). Wire size not less than 4 mm² (12 AWG). The insulation type should be appropriate for the type of installation method used and must meet IEC 61730 and Safety Class II requirements.

- Insulation level: 1,8 kV (conductor-conductor).
- Temperature: -40°C up to +90°C (-40 °F up to 190 °F) at least.
- Construction of conductor: tinned stranded copper wire with copper purity greater than 99,9%.
- Primary insulation: cross-linked polyethylene (XLPE), sunlight and moisture resistant, flame retardant. Suitable for conduit and raceways installed underground.
- Insulation (jacket): thermoplastic, sunlight resistant, flame retardant, water resistant.
- Minimum cable outer diameter with insulation – 5,2 mm (2,05 inch).
- Minimum conductor cross-section – 4 mm² (12 AWG).

SoliTek recommends installers use only sunlight resistant cables qualified for direct current (DC) wiring in PV systems. Cables should be fixed to the mounting structure in such a way that mechanical damage of the cable and/or the module is avoided. Do not apply stress to the cables. For fixing, use appropriate means, such as sunlight resistant cable ties and/or wire management clips. While the cables are sunlight resistant and waterproof, where possible, avoid direct sunlight exposure and water immersion of the cables.

Standard length of cables from the junction boxes is 1,2 m (47,24 inch). It is intended that two panels would interconnect in the system.

2.5 | GROUNDING

Module grounding must be done in accordance with the electrical design and construction specifications, procedures, regulations and other special grounding requirements applicable to the installation sites. If grounding is needed, it should be done accordingly:

Framed type modules grounding

Holes marked with a grounding mark on the frame can only be used for grounding. Do not drill additional grounding holes on module frame.

The grounding conductor or strap may be copper, copper alloy, or any other material acceptable for use as an electrical conductor in accordance with local electric codes and regulations.

The grounding conductor must then make a connection to earth using a suitable earth ground electrode.

A bolted connection is required, it incorporates:

- A bolt size of M4.
- A tooth washer under the bolt head or a serrated bolt must penetrate nonconductive coatings like anodized frame.
- A fasten nut suitable for M4 bolt.
- All hardware shall be of nonferrous metal, 300-series stainless steel, or suitably corrosion protected.
- The recommended torque of locking the nut is $2\text{ Nm} \pm 2.2\text{ Nm}$ (1,48 \pm 1,62 ft-lb).
- Grounding bolt has to go through all the connecting elements.

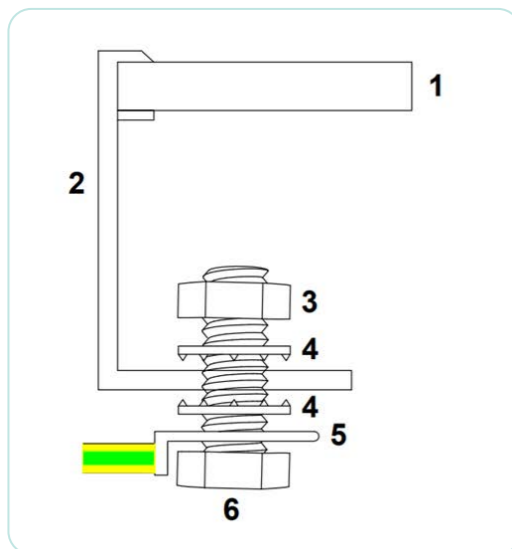

- 1 - PV module
- 2 - PV Frame
- 3 - M4 Nut
- 4 - M4 tooth washer
- 5 - Cable shoe (Haupa)
- 6 - M4 Bolt

Devices listed and identified for grounding metallic frames of PV modules are permitted to ground the exposed metallic frames of the module to grounded mounting structures.

In any case the grounding screws or other parts have to be used separately from mounting parts of the module.

Alternate grounding options built through mounting system are acceptable as long as they have been IEC and UL approved.

Grounding resistance of grounding structure shall be reached according to local regulations, Eurocodes, or other legal normative references.

Frameless type modules grounding

Due to that modules are without frame, grounding is not foreseen. Other PV plant equipment should be grounded according to the local and national electrical codes.

2.6 | CONNECTORS

Connectors for SoliTek PV panels are Stäubli MC4-Evo 2. Keep connectors dry and clean and ensure that connector caps are hand tight before connecting the modules. Do not attempt making an electrical connection with wet, soiled, or otherwise faulty connectors. Avoid sunlight exposure and water immersion of the connectors. Avoid connectors resting on the ground or roof surface. Do not disconnect under load. Faulty connections can result in arcs and electrical shock. Check that all electrical connections are securely fastened. Make sure that all locking connectors are fully engaged and locked.

2.7 | BYPASS DIODES

The PV module's junction box contains 3 bypass diodes (one in each part of split junction box; Schottky type) connected in parallel with the PV cell strings. In the case of partial shading (hot-spot effect), the diodes bypass the current generated by the non-shaded cells, thereby limiting module heating and performance losses.

Bypass diodes are not overcurrent protection devices. Bypass diodes divert current from the cell strings in the event of partial shading. The characteristics of these diodes:

- Voltage rating – 50 V.
- Current rating – 25 A.

FIRE CLASS RATING



SoliTek SOLID Bifacial and Blackstar modules have been approved by the IEC fire test and achieved Flammability Class A. Fire test was performed at the inclination of 127 mm (5 inch) per 300 mm (11,81 inch), as prescribed in the point A.2.5 of IEC 61730-2.

SoliTek SOLID Bifacial has fire type of 28 rating according to UL1703-2 standard. SoliTek Blackstar has fire type of 29 rating according to UL1703-2 standard.

Mechanical mounting

The mechanical loads described in this manual are the test loads. For calculating the equivalent maximum design loads, a safety factor of 1.5 (Design load x 1.5 safety factor = Mechanical test load) needs to be considered in compliance with the requirements of the local laws and regulations.

3.1 GENERAL REQUIREMENTS

Modules can be mounted in landscape or portrait orientation. For the bifacial modules, in order to get notable bifacial gain, the distance between the bottom of modules and the roof or ground surface shall be at least 0,8 m (31,50 inch). Also, the bifacial gain increases significantly if modules are installed above white, light reflecting surfaces (under surfaces with high albedo value). If the mounting rails are installed across the module, bifaciality effect will be lower due to back-side cells shading.

Please observe the safety regulations and installation instructions included with the mounting system. If necessary, please contact the supplier directly for further information.

The modules must be safely set onto the mounting rail. The whole rail supporting the photovoltaic system must be strong enough to resist potential mechanical pressures caused either by wind or snow, in accordance with local, regional and state safety (and other associated) standards. Mounting system shall be tested and inspected by the third-party testing institution with static mechanical analysis capacity in accordance with local national standards or international standards. Before installing modules on a roof, ensure that the roof construction is suitable. In addition, any roof penetration required to mount the modules must be properly sealed to prevent leaks.

Make sure that the mounting rail will not deform or affect the modules when it expands as a result of thermal expansion. The module can appear thermal expansion and cold contraction, thus, the interval between two adjoining modules shall be no lesser than 10 mm (0,39 inch). Do not attempt to drill holes in the glass surface and the frames of the modules as this will void the warranty. The mounting method must not result in the direct contact of dissimilar metals with the aluminum frame of the modules that will result in galvanic corrosion.



The mounting components must be made of durable, anti-corrosive and UV-resistant materials (stainless steel and anodized aluminum components are recommended).

3.2 MOUNTING WITH CLAMPS

Use at minimum 4 laminate clamps to fix modules on the mounting rails. Modules clamps metal parts should not come into contact with the front or back glass. When choosing this type of clamp-mounting method, use at least four clamps on each module; two clamps should be attached on each long side. Depending on local wind and snow loads, additional clamps may be required to ensure that modules can bear the load.

Clamps tightening torque should be at least 15 Nm (11,06 ft-lb), but not greater than 20 Nm (14,75 ft-lb). Usually, 15 Nm (11,06 ft-lb), is reached when two aluminum profiles touch each other. When a module is installed in portrait orientation on the pitched roof which has >45° slope, additional hook in the bottom of the module is required.

Product	Visualization	Length options:	Material / surface
Laminate middle clamp CLICK 6.8		1. 100 mm (3,94 inch) 2. 150 mm (5,91 inch)	ENAW 6063/T66; EPDM; mill finish / black
Laminate end clamp CLICK 6.8		1. 100 mm (3,94 inch) 2. 150 mm (5,91 inch)	ENAW 6063/T66; EPDM; mill finish / black

Table 1. Laminated, CLICK 6.8 type, clamp details

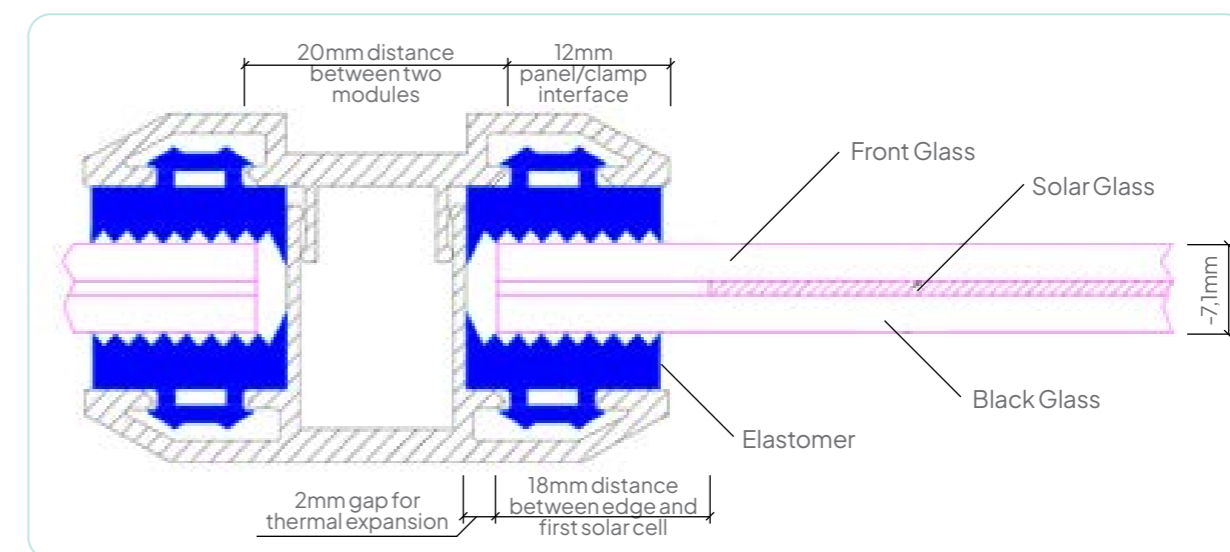

Figure 2. Recommended clamp dimensions for the SoliTek PV Glass-Glass modules

3.3 SOLID Black, Semi-clear, Satin, Agro Frameless

With transversal rails

Position of rails		Dimensions and Load Values			
		SOLID Semi-clear B.96	SOLID Black B.96	SOLID Satin B.96	SOLID Agro B.64
	A	1140mm	1140mm	1140mm	1140 mm
	B	1768 mm	1768 mm	1768 mm	1768 mm
	C	398±50 mm	398±50 mm	398±50 mm	398±50 mm
	Snow	2400 Pa			
	Wind	2400 Pa			

Table 2 Frameless module mounting with 100 mm length clamps and transversal rails

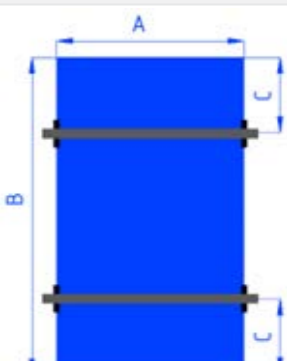
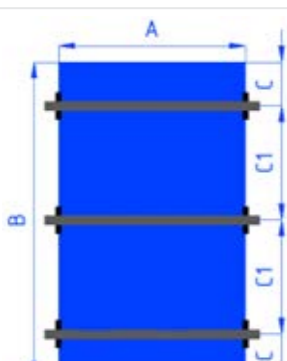
Position of rails		Dimensions and Load Values			
		SOLID Semi-clear B.96	SOLID Black B.96	SOLID Satin B.96	SOLID Agro B.64
	A	1140 mm	1140 mm	1140 mm	1140 mm
	B	1768 mm	1768 mm	1768 mm	1768 mm
	C	398±50 mm	398±50 mm	398±50 mm	398±50 mm
	Snow	5400 Pa			
	Wind	3600 Pa			
	A	1140 mm	1140 mm	1140 mm	1140 mm
	B	1768 mm	1768 mm	1768 mm	1768 mm
	C	256±50 mm	256±50 mm	256±50 mm	256±50 mm
	C1	628±50 mm	628±50 mm	628±50 mm	628±50 mm
	Snow	8100 Pa			
	Wind	4200 Pa			

Position of rails		Dimensions and Load Values			
		BLACKSTAR (Satin) B.96	SOLID Black (Semi-clear) B.96 35 mm	SOLID Black (Semi-clear) B.96 40 mm	MAGNUS B.108
	A	1140 mm	1140 mm	1140 mm	1140 mm
	B	1768 mm	1768 mm	1768 mm	1768 mm
	C	190±50 mm	190±50 mm	190±50 mm	190±50 mm
	C1	463±50 mm	463±50 mm	463±50 mm	463±50 mm
	Snow	10500 Pa			
	Wind	5400 Pa			

Table 3 Frameless module mounting with 150 mm length clamps and transversal rails

3.4 BLACKSTAR, SOLID Black 35(40) mm, SOLID Semi-clear 35(40) mm, SOLID Satin 35(40) mm, SOLID Agro 35(40) mm, Magnus Framed mounting

When choosing this type of clamp-mounting method, use at least four clamps on each module, two clamps should be attached on each side of the module. Modules clamps should not come into contact with the front glass and must not deform the frame. Be sure to avoid shadowing effects on the solar cells from the module clamps. The module frame is not to be modified under any circumstances. Do not to block the drain hole of the frame. The length of clamp should be at least 30 mm (1,18 inch). The clamp must overlap the module frame by at least 5 mm (0,2 inch), but no more than 10mm (0,4 inch).

With transversal rails

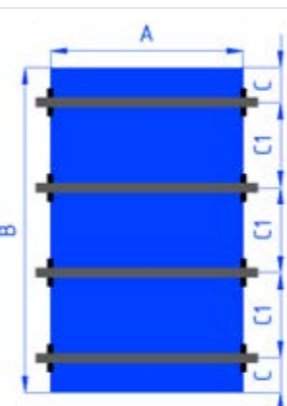
Position of rails		Dimensions and Load Values			
		BLACKSTAR (Satin) B.96	SOLID Black (Semi-clear) B.96 35 mm	SOLID Black (Semi-clear) B.96 40 mm	MAGNUS B.108
	A	1134 mm	1134 mm	1134 mm	1134 mm
	B	1762 mm	1762mm	1762 mm	1961 mm
	C	396±50 mm	396±50 mm	396±50 mm	440±50 mm
	Snow	5400 Pa	6200 Pa	6800 Pa	5400 Pa
	Wind	2400 Pa	3600 Pa	3800 Pa	2400 Pa

	A	1134 mm	1134 mm	1134 mm	1134 mm
	B	1762 mm	1762 mm	1762 mm	1961 mm
	C	256±50 mm	256±50 mm	256±50 mm	285±50 mm
	C1	625±50 mm	625±50 mm	625±50 mm	969±50 mm
	Snow	8100 Pa	9000 Pa	9400 Pa	7200 Pa
	Wind	3600 Pa	4000 Pa	4200 Pa	3600 Pa
	A	N/A	1134 mm	1134 mm	1134 mm
	B		1762 mm	1762 mm	1961 mm
C	188±50 mm		188±50 mm	213±50 mm	
	C1	462±50 mm	462±50 mm	510±50 mm	
	Snow	N/A	10500 Pa		8100 Pa
Wind	N/A	5400 Pa		3800 Pa	

Table 4 Framed module mounting with clamps and transversal rails

Position of rails	Dimensions and Load Values				
	SOLID Satin B.96 35 mm	SOLID Satin B.96 40 mm	SOLID Agro B.64 35 mm	SOLID Agro B.64 40mm	
	A	1134 mm	1134 mm	1134 mm	1134 mm
	B	1762 mm	1762 mm	1762 mm	1762 mm
	C	398±50 mm	398±50 mm	398±50 mm	398±50 mm
	Snow	6200 Pa	6800 Pa	6200 Pa	6800 Pa
Wind	3600 Pa	3800 Pa	3600 Pa	3800 Pa	
	A	1134 mm	1134 mm	1134 mm	1134 mm
	B	1762 mm	1762 mm	1762 mm	1762 mm
	C	256±50 mm	256±50 mm	256±50 mm	256±50 mm
	C1	625±50 mm	625±50 mm	625±50 mm	625±50 mm
Snow	9000 Pa	9400 Pa	9000 Pa	9400 Pa	
Wind	4000 Pa	4200 Pa	4000 Pa	4200 Pa	

Table 5 Framed module mounting with clamps and transversal

Without transversal rails or rails are perpendicular to the long side frame

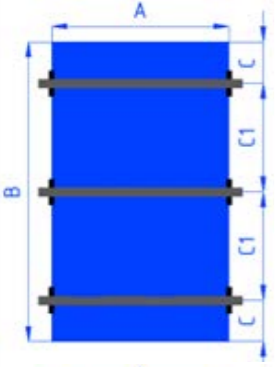
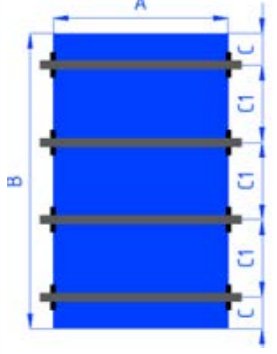
Without transversal rails or rails are perpendicular to the long side frame	Dimensions and Load Values				
	BLACKSTAR (Satin) B.96	SOLID Black (Semi-Clear) B.96 35 mm	SOLID Black (Semi-clear) B.96 40 mm	MAGNUS B.108	
	A	1134 mm	1134 mm	1134 mm	1134 mm
	B	1762 mm	1762 mm	1762 mm	1961 mm
	C	20~200 mm	20~200 mm	20~200 mm	20~200 mm
	Snow	2100 Pa	2400 Pa	2600 Pa	1600 Pa
Wind	1600 Pa	1800 Pa	2000 Pa	1600 Pa	
	A	1134 mm	1134 mm	1134 mm	1134 mm
	B	1762 mm	1762 mm	1762 mm	1961 mm
	C	20~200 mm	20~200 mm	20~200 mm	20~200 mm
	C1	881±50 mm	881±50 mm	881±50 mm	980±50 mm
Snow	3600 Pa	4200 Pa	4400 Pa	3600 Pa	
Wind	2400 Pa	2600 Pa	2800 Pa	2400 Pa	
	A	1134 mm	1134 mm	1134 mm	1134 mm
	B	1762 mm	1762 mm	1762 mm	1961 mm
	C	20~200 mm	20~200 mm	20~200 mm	20~200 mm
	C1	671±50 mm	671±50 mm	671±50 mm	720±50 mm
	C2	420±50 mm	420±50 mm	420±50 mm	521±50 mm
	Snow	5800 Pa	6400 Pa	7100 Pa	5800 Pa
Wind	2800 Pa	3000 Pa	3400 Pa	2800 Pa	

Table 6 Framed module mounting with clamps and without transversal rails

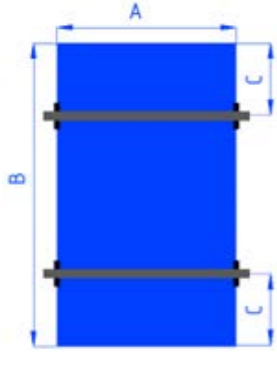
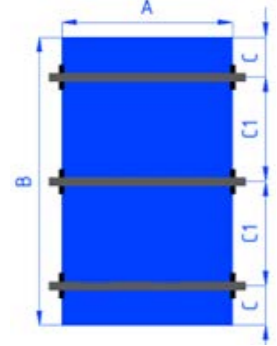
Without transversal rails or rails are perpendicular to the long side frame	Dimensions and Load Values				
	SOLID Satin B.96 35 mm	SOLID Satin B.96 40 mm	SOLID Agro B.64 35 mm	SOLID Agro B.64 40 mm	
	A	1134 mm	1134 mm	1134 mm	1134 mm
	B	1762 mm	1762 mm	1762 mm	1762 mm
	C	20~200 mm	20~200 mm	20~200 mm	20~200 mm
	Snow	2400 Pa	2600 Pa	2400 Pa	2600 Pa
	Wind	1800 Pa	2000 Pa	1800 Pa	2000 Pa
	A	1134 mm	1134 mm	1134 mm	1134 mm
	B	1762 mm	1762 mm	1762 mm	1762 mm
	C	20~200 mm	20~200 mm	20~200 mm	20~200 mm
	C1	881±50 mm	881±50 mm	881±50 mm	881±50 mm
	Snow	4200 Pa	4400 Pa	4200 Pa	4400 Pa
Wind	2600 Pa	2800 Pa	2600 Pa	2800 Pa	

Table 7 Framed module mounting with clamps and without transversal rails

With insertion system

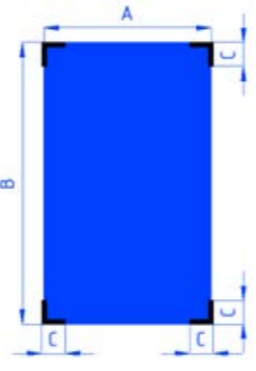
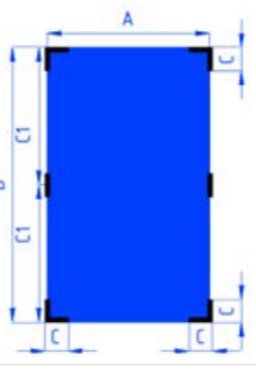
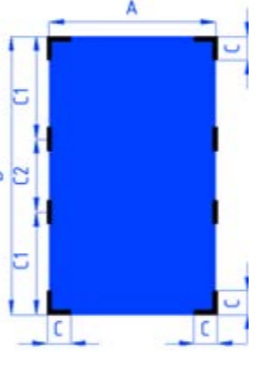
With insertion system	Dimensions and Load Values				
	SOLID Black (Semi-clear) B.96 35 mm	SOLID Black (Semi-clear) B.96 40 mm	SOLID Satin (Agro) B.96 (64) 35 mm	SOLID Satin (Agro) B.96 (64) 40 mm	
	A	A=1134 mm	A=1134 mm	A=1134 mm	A=1134 mm
	B	B=1762 mm	B=1762 mm	B=1762 mm	B=1762 mm
	Snow	2400 Pa			
Wind	2400 Pa				
	A	A=1134 mm	A=1134 mm	A=1134 mm	A=1134 mm
	B	B=1762 mm	B=1762 mm	B=1762 mm	B=1762 mm
	Snow	5400 Pa	6450 Pa	5400 Pa	6450 Pa
	Wind	3600 Pa	3600 Pa	3600 Pa	3600 Pa

Table 8 Framed module mounting with insertion system

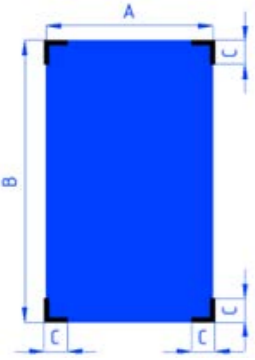
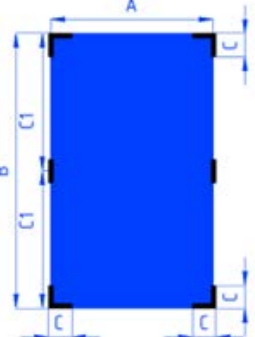
Mounting with bolts

The module must be attached and supported by four M8 stainless steel bolts through the indicated mounting holes on the transversal bars. Torque on the clamp bolt has to be in range of 8÷10 Nm (5,9÷7,38 ft-lb). Transversal bars positioning is shown in Figure 3.

If additional mounting points are required depending on the local wind and snow loads, then mounting solution with clamping hardware has to be chosen.

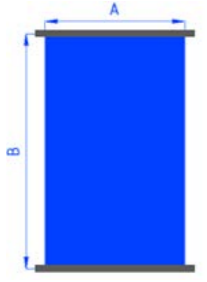
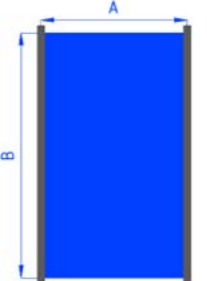
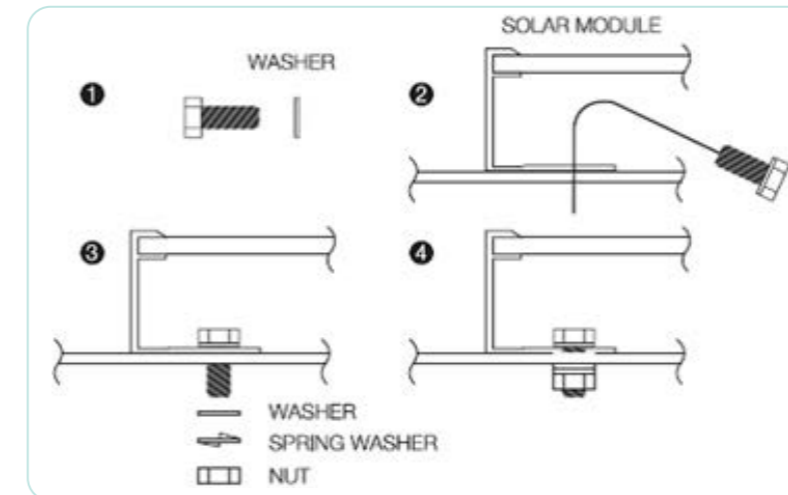

Figure 3. Mounting using bolts on the transversal bars.

Mounting with bolts can be done only through dedicated predrilled holes in the frame. Drilling new holes is forbidden and will void the warranty.

Figure 4. Position of mounting holes of BLACKSTAR, SOLID BLACK, Semi-Clear, Satin, Agro Framed modules

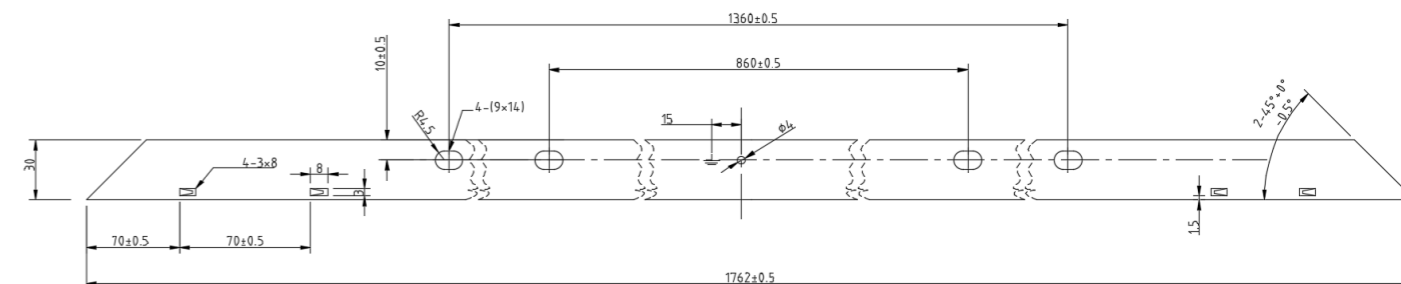
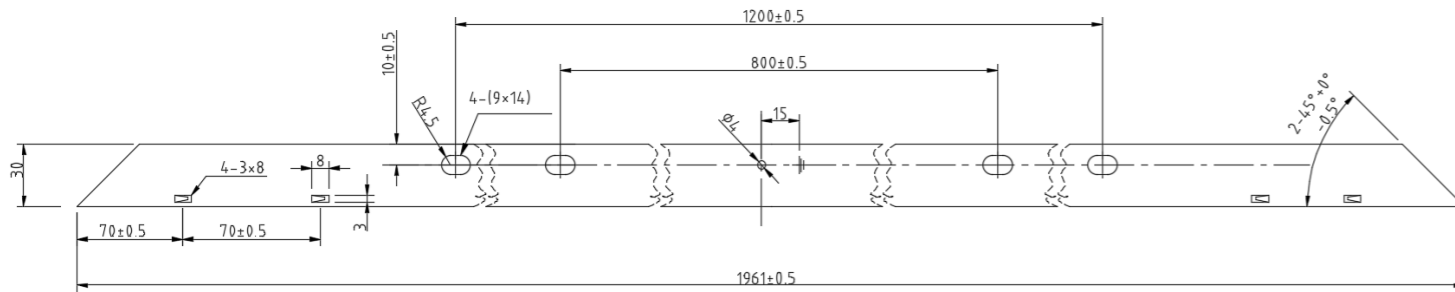

Figure 5. Position of mounting holes of MAGNUS module



Maintenance & Specifications

4.1 MAINTENANCE

In order to ensure optimum module performance, SoliTek recommends the following: If necessary, the glass front of the module can be cleaned with water and a soft sponge or cloth. A mild, non-abrasive detergent can be used to remove more stubborn stains. Check the electrical and mechanical connections periodically and make sure they are clean, safe, complete and secure. In the event of a problem, consult with a licensed/qualified person.

3.5 POSITION OF THE JUNCTION BOX

For the distance between junction box and edge of the module or other dimensions of junction box position and areas please refer to figures shown below.

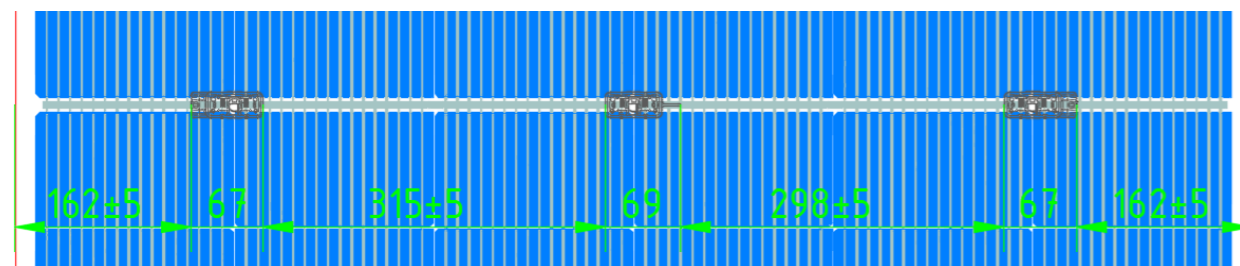

Figure 6. Position of the junction box of frameless module

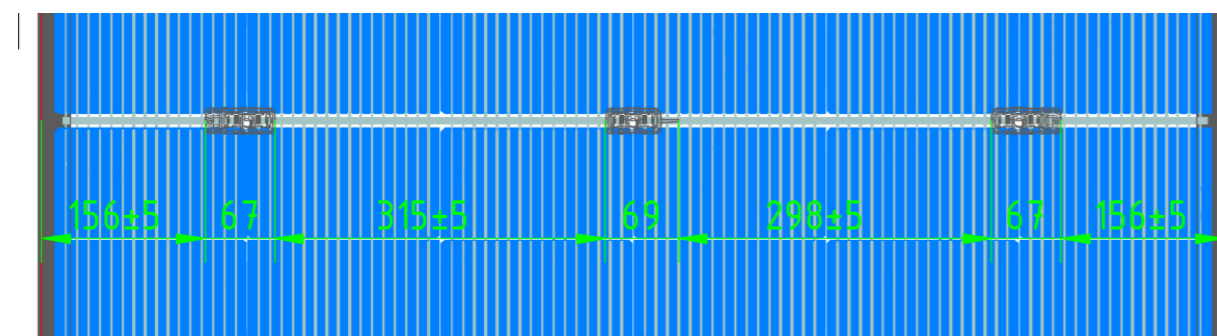

Figure 7. Position of junction box of framed module

4.2 | SPECIFICATIONS

Parameter \ Model	BLACKSTAR B.96	SOLID Black (Semi-Clear) B.96 35(40) mm	BLACKSTAR Satin B.96	MAGNUS B.108
Test conditions	STC	STC	STC	STC
Nominal power	455 W	455 W	445 W	510 W
Electrical Data @STC				
Maximum Power (Pmax), W	455	455	445	510
Voltage at Maximum Power (Vmpp), V	29,71	29,71	29,40	33,34
Current at Maximum Power (Imp), A	15,31	15,31	15,14	15,30
Open Circuit Voltage (Voc), V	34,82	34,82	34,40	39,06
Short Circuit Current (Isc), A	15,97	15,97	15,79	15,95
Thermal Data				
Operating Temperature Range	-40°C ÷ 85°C (-40°F ÷ 185°F)	-40°C ÷ 85°C (-40°F ÷ 185°F)	-40°C ÷ 85°C (-40°F ÷ 185°F)	-40°C ÷ 85°C (-40°F ÷ 185°F)
Temperature Coefficient of Pmax	-0,362%/°C (°F)	-0,362%/°C (°F)	-0,362%/°C (°F)	-0,362%/°C (°F)
Temperature Coefficient of Voc	-0,265%/°C (°F)	-0,265%/°C (°F)	-0,265%/°C (°F)	-0,265%/°C (°F)
Temperature Coefficient of Isc	+0,036%/°C (°F)	+0,036%/°C (°F)	+0,036%/°C (°F)	+0,036%/°C (°F)
Size & weight data				
Length	1762 mm	1762 mm	1762 mm	1961 mm
Width	1134 mm	1134 mm	1134 mm	1134 mm
Thickness	30 mm	35(40) mm	30 mm	30 mm
Weight	25,5 kg	35(36) kg	25,5 kg	28,5 kg
Mounting method				
Reference to chapter	3.3	3.3	3.3	3.3
Other				
Maximum reverse current, A	30			
Fire class, IEC 61730/UL 61730	A/Type II			
Maximum system voltage, V	1500			

Table 9. Electrical and mechanical parameters table.

Parameter \ Model	SOLID Semi-clear B.96	SOLID Black B.96	SOLID Satin B.96	SOLID Agro B.64
Test conditions	STC	STC	STC	STC
Nominal power	455 W	455 W	445 W	300 W
Electrical Data @STC				
Maximum Power (Pmax), W	455	455	445	300
Voltage at Maximum Power (Vmpp), V	29,71	29,71	29,40	19,60
Current at Maximum Power (Imp), A	15,31	15,31	15,14	15,31
Open Circuit Voltage (Voc), V	34,82	34,82	34,40	22,76
Short Circuit Current (Isc), A	15,97	15,97	15,79	15,97
Thermal Data				
Operating Temperature Range	-40°C ÷ 85°C (-40°F ÷ 185°F)	-40°C ÷ 85°C (-40°F ÷ 185°F)	-40°C ÷ 85°C (-40°F ÷ 185°F)	-40°C ÷ 85°C (-40°F ÷ 185°F)
Temperature Coefficient of Pmax	-0,30%/°C (°F)	-0,30%/°C (°F)	-0,30%/°C (°F)	-0,30%/°C (°F)
Temperature Coefficient of Voc	-0,25%/°C (°F)	-0,25%/°C (°F)	-0,25%/°C (°F)	-0,25%/°C (°F)
Temperature Coefficient of Isc	+0,045%/°C (°F)	+0,045%/°C (°F)	+0,045%/°C (°F)	+0,045%/°C (°F)
Size & weight data				
Length	1772±2 mm	1772±2 mm	1772±2 mm	1772±2 mm
Width	1144±2	1144±2	1144±2 mm	1144±2 mm
Thickness	7,2 mm	7,2 mm	7,2 mm	7,2 mm
Weight	33kg	33 kg	33 kg	33 kg
Mounting method				
Reference to chapter	3.2	3.2	3.2	3.2
Other				
Maximum reverse current, A	30			
Fire class, IEC 61730/UL 61730	A/Type II			
Maximum system voltage, V	1500			

Table 10. Electrical and mechanical parameters table.

Parameter \ Model	SOLID Satin B.96 35 mm	SOLID Satin B.96 40 mm	SOLID Agro B.64 35 mm	SOLID Agro B.64 40 mm
Test conditions	STC	STC	STC	STC
Nominal power	445 W	445 W	300 W	300 W
Electrical Data @STC				
Maximum Power (Pmax), W	445	445	300	300
Voltage at Maximum Power (Vmpp), V	29,40	29,40	19,60	19,60
Current at Maximum Power (Impp), A	15,14	15,14	15,31	15,31
Open Circuit Voltage (Voc), V	34,40	34,40	22,78	22,78
Short Circuit Current (Isc), A	15,79	15,79	15,97	15,97
Thermal Data				
Operating Temperature Range	-40°C ÷ 85°C (-40°F ÷ 185°F)	-40°C ÷ 85°C (-40°F ÷ 185°F)	-40°C ÷ 85°C (-40°F ÷ 185°F)	-40°C ÷ 85°C (-40°F ÷ 185°F)
Temperature Coefficient of Pmax	-0,362%/°C (°F)	-0,362%/°C (°F)	-0,30%/°C (°F)	-0,30%/°C (°F)
Temperature Coefficient of Voc	-0,265%/°C (°F)	-0,265%/°C (°F)	-0,25%/°C (°F)	-0,25%/°C (°F)
Temperature Coefficient of Isc	+0,036%/°C (°F)	+0,036%/°C (°F)	+0,045%/°C (°F)	+0,045%/°C (°F)
Size & weight data				
Length	1762mm	1762mm	1762 mm	1762 mm
Width	1134 mm	1134 mm	1134 mm	1134 mm
Thickness	35 mm	40 mm	35 mm	40 mm
Weight	35 kg	36kg	35 kg	36 kg
Mounting method				
Reference to chapter	3.3			
Other				
Maximum reverse current, A	30			
Fire class, IEC 61730/UL 61730	A/Type II			
Maximum system voltage, V	1500			

Table 11. Electrical and mechanical parameters table.

The electrical characteristics are within of the indicated values of $I_{sc} (\phi I_{sc}) \pm 3\%$, $V_{oc} (\phi V_{oc}) \pm 3,5\%$ and $P_{MPP} (\phi P_{max}) \pm 5\%$, under Standard Test Conditions (STC) (irradiance of 1000 W/m², AM1.5 spectrum, and a cell temperature of 25°C / 77°F)

All SoliTek SOLID PV panels correspond to electrical safety class II.

Disclaimer of liability

Since it is impossible for SoliTek to control installation, operation, application and maintenance of the photovoltaic system according to this instruction. SoliTek does not accept responsibility and expressly disclaims liability for any loss, damage or expense arising out of or in any way connected with such installation, operation, use or maintenance.

SoliTek will not take any responsibilities for any possible violation of patent rights and third party rights that are related to application of the solar energy system. No permission of patents is given through implication.

The information of this instruction is from knowledge and experiences of SoliTek. However, the instructions and suggestions of this instruction do not make an external or internal of guarantee. SoliTek reserves the right to revise this instruction, products and all the information about products without prior notification to customers.



**Energy
for all your
needs**